

AUTOBIANCHI

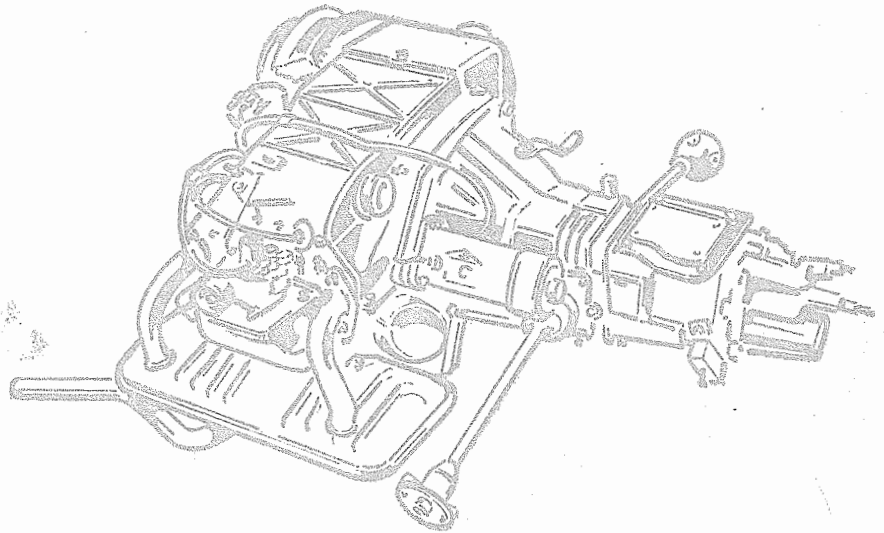

bianchina

panoramica

Tipo 120 B

giardiniera

Tipo 120 F

furgoncino

Tipo 264

furgoncino
302

Tipo 264 E

CATALOGO PARTI DI RICAMBIO
CATALOGUE DE PIÈCES DÉTACHÉES
BILDER ATZUGTEILE KATALOG
OPPARTS PARTS CATALOG
CATALOGO DE PIEZAS DE REPOSIÇÃO





AUTOBIANCHI

ricambi originali

603.82.031

	VERSIONI BASE Bianchina Panoramica e derivati	Versions-base	Grundausführungen	Basic Versions	Versiones básicas
*					
01	Panoramica con guida sinistra	Panoramica conduite à gauche	Panorama Linkslenkung	Panoramica LHD	Panorámica conducción izquierda
02	Panoramica con guida destra	Panoramica conduite à droite	Panorama Rechtslenkung	Panoramica RHD	Panorámica conducción derecha
03	Furgoncino con guida sinistra	Fourgonnette conduite à gauche	Lieferwagen Linkslenkung	Van LHD	Furgoneta conducción izquierda
04	Furgoncino con guida destra	Fourgonnette conduite à droite	Lieferwagen Rechtslenkung	Van RHD	Furgoneta conducción derecha
05	Furgoncino 320/2 con guida sinistra	Fourgonnette 320/2 conduite à gauche	Lieferwagen 320/2 Linkslenkung	Van 320/2 LHD	Furgoneta 320/2 conducción izquierda
06	Furgoncino 320/2 con guida destra	Fourgonnette 320/2 conduite à droite	Lieferwagen 320/2 Rechtslenkung	Van 320/2 RHD	Furgoneta 320/2 conducción derecha
07	Giardiniera con guida sinistra	Jardinière conduite à gauche	Kombiwagen Linkslenkung	Station Wagon LHD	Comercial conducción izquierda
08	Giardiniera con guida destra	Jardinière conduite à droite	Kombiwagen Rechtslenkung	Station Wagon RHD	Comercial conducción derecha

* codici delle versioni base (pag. 11)

* codes des versions-base (page 12)

* Kennnummern der Grundausführungen (s. 12)

* Basic version code Nos. (page 13)

* Códigos de las versiones básicas (pag. 13)

Consultare questo cartoncino per conoscere la validità dei sottogruppi per il veicolo che interessa.

Consultez cette fiche pour connaître la validité des sousgroupes pour le véhicule qui vous intéresse.

Dieses Blatt dient zur Feststellung der Untergruppengültigkeit des interessierenden Fahrzeugs.

Consult this card to know the applicability of Subgroups to the vehicle involved.

Para conocer la aplicación de los subgrupos referentes al vehículo que interesa, consúltese esta ficha.

Bianchina Panoramica e derivati - **VALIDITÀ DEI SOTTOGRUPPI**

Validité des Sousgroupes
Gültigkeit der Untergruppen

Subgroup Applicability
Validez de los subgrupos

*

Sgr.	01	02	03	04	05	06	07	08	Sgr.	01	02	03	04	05	06	07	08	Sgr.	01	02	03	04	05	06	07	08	Sgr.	01	02	03	04	05	06	07	08	Sgr.	01	02	03	04	05	06	07	08											
A0.01	=	=	=	=	=	=	=	=	B2.04	=	=	=	=	=	=	=	=	D3.16	=	=	=	=	=	=	=	=	F6.29/1	=	=	=	=	=	=	=	=	F6.65	=	=	=	=	=	=	=	=											
A1.01	=	=	=	=	=	=	=	=	B2.07	=	=	=	=	=	=	=	=	E1.01	=	=	=	=	=	=	=	=	F6.29/2	=	=	=	=	=	=	=	=	Z1.01	=	=	=	=	=	=	=	=											
A1.02	=	=	=	=	=	=	=	=	B2.10	=	=	=	=	=	=	=	=	E3.01	=	=	=	=	=	=	=	=	F6.29/3	=	=	=	=	=	=	=	=	=	=	=	=	=	=	=	=												
A1.03	=	=	=	=	=	=	=	=	B2.24	=	=	=	=	=	=	=	=	E3.01/1	=	=	=	=	=	=	=	=	F6.29/4	=	=	=	=	=	=	=	=	=	=	=	=	=	=	=	=												
A1.05	=	=	=	=	=	=	=	=	B4.01	=	=	=	=	=	=	=	=	E3.01/2	=	=	=	=	=	=	=	=	F6.29/5	=	=	=	=	=	=	=	=	=	=	=	=	=	=	=	=	=											
A1.06	=	=	=	=	=	=	=	=	B4.04	=	=	=	=	=	=	=	=	F1.01	=	=	=	=	=	=	=	=	F6.29/6	=	=	=	=	=	=	=	=	=	=	=	=	=	=	=	=	=	=										
A1.07	=	=	=	=	=	=	=	=	C1.01	=	=	=	=	=	=	=	=	F2.01	=	=	=	=	=	=	=	=	F6.29/7	=	=	=	=	=	=	=	=	=	=	=	=	=	=	=	=	=	=										
A2.01	=	=	=	=	=	=	=	=	C1.01/1	=	=	=	=	=	=	=	=	F3.01	=	=	=	=	=	=	=	=	F6.29/9	=	=	=	=	=	=	=	=	=	=	=	=	=	=	=	=	=	=										
A2.02	=	=	=	=	=	=	=	=	C1.02	=	=	=	=	=	=	=	=	F4.01	=	=	=	=	=	=	=	=	F6.29/10	=	=	=	=	=	=	=	=	=	=	=	=	=	=	=	=	=	=	=									
A2.03	=	=	=	=	=	=	=	=	C1.02/1	=	=	=	=	=	=	=	=	F4.01/1	=	=	=	=	=	=	=	=	F6.29/11	=	=	=	=	=	=	=	=	=	=	=	=	=	=	=	=	=	=	=	=								
A2.03/1	=	=	=	=	=	=	=	=	C1.06	=	=	=	=	=	=	=	=	F4.01/2	=	=	=	=	=	=	=	=	F6.29/12	=	=	=	=	=	=	=	=	=	=	=	=	=	=	=	=	=	=	=	=								
A2.04	=	=	=	=	=	=	=	=	C1.07	=	=	=	=	=	=	=	=	F4.01/3	=	=	=	=	=	=	=	=	F6.29/13	=	=	=	=	=	=	=	=	=	=	=	=	=	=	=	=	=	=	=	=	=							
A2.05	=	=	=	=	=	=	=	=	C1.30	=	=	=	=	=	=	=	=	F5.01	=	=	=	=	=	=	=	=	F6.29/14	=	=	=	=	=	=	=	=	=	=	=	=	=	=	=	=	=	=	=	=	=	=						
A2.06	=	=	=	=	=	=	=	=	C1.32	=	=	=	=	=	=	=	=	F5.03	=	=	=	=	=	=	=	=	F6.32	=	=	=	=	=	=	=	=	=	=	=	=	=	=	=	=	=	=	=	=	=	=						
A2.21	=	=	=	=	=	=	=	=	C1.35	=	=	=	=	=	=	=	=	F5.03/1	=	=	=	=	=	=	=	=	F6.32/1	=	=	=	=	=	=	=	=	=	=	=	=	=	=	=	=	=	=	=	=	=	=	=					
A2.56	=	=	=	=	=	=	=	=	D2.01	=	=	=	=	=	=	=	=	F5.05	=	=	=	=	=	=	=	=	F6.34	=	=	=	=	=	=	=	=	=	=	=	=	=	=	=	=	=	=	=	=	=	=	=	=				
A3.01	=	=	=	=	=	=	=	=	D2.02	=	=	=	=	=	=	=	=	F6.02	=	=	=	=	=	=	=	=	F6.34/1	=	=	=	=	=	=	=	=	=	=	=	=	=	=	=	=	=	=	=	=	=	=	=	=	=			
A3.01/1	=	=	=	=	=	=	=	=	D2.10	=	=	=	=	=	=	=	=	F6.02/1	=	=	=	=	=	=	=	=	F6.34/2	=	=	=	=	=	=	=	=	=	=	=	=	=	=	=	=	=	=	=	=	=	=	=	=	=	=		
A4.07	=	=	=	=	=	=	=	=	D3.01	=	=	=	=	=	=	=	=	F6.06	=	=	=	=	=	=	=	=	F6.34/3	=	=	=	=	=	=	=	=	=	=	=	=	=	=	=	=	=	=	=	=	=	=	=	=	=	=		
A4.09	=	=	=	=	=	=	=	=	D3.05	=	=	=	=	=	=	=	=	F6.08	=	=	=	=	=	=	=	=	F6.34/4	=	=	=	=	=	=	=	=	=	=	=	=	=	=	=	=	=	=	=	=	=	=	=	=	=	=		
B1.01	=	=	=	=	=	=	=	=	D3.10	=	=	=	=	=	=	=	=	F6.14	=	=	=	=	=	=	=	=	F6.35	=	=	=	=	=	=	=	=	=	=	=	=	=	=	=	=	=	=	=	=	=	=	=	=	=	=		
B1.05	=	=	=	=	=	=	=	=	D3.10/1	=	=	=	=	=	=	=	=	F6.14/1	=	=	=	=	=	=	=	=	F6.35/1	=	=	=	=	=	=	=	=	=	=	=	=	=	=	=	=	=	=	=	=	=	=	=	=	=	=	=	
B2.01	=	=	=	=	=	=	=	=	D3.14	=	=	=	=	=	=	=	=	F6.29	=	=	=	=	=	=	=	=	F6.35/2	=	=	=	=	=	=	=	=	=	=	=	=	=	=	=	=	=	=	=	=	=	=	=	=	=	=	=	=

* Codici delle versioni base.

= Vale il sottogruppo della colonna Sgr.

* Codes des versions-base.

= Le sousgroupe valable est celui indiqué à la colonne « Sgr. ».

* Kennnummern der Grundauführungen.

= Die Untergruppen sind in der Spalte « Sgr. » angegeben.

* Basic version codes.

= Applicable Subgroup is shown in the « Sgr. » column.

* Códigos de las versiones básicas.

= Aplicable el subgrupo de la columna « Sgr. ».



AUTOBIANCHI

4ª EDIZIONE

bianchina *panoramica* Tipo 120 B
giardiniera Tipo 120 F
furgoncino Tipo 264
furgoncino
320/2 Tipo 264 E

CATALOGO PARTI DI RICAMBIO
CATALOGUE DE PIÈCES DÉTACHÉES
E R S A T Z T E I L K A T A L O G
S P A R E P A R T S C A T A L O G
CATÁLOGO DE PIEZAS DE REPUESTO

S. A. T. - UFF. PUBBLICAZIONI TECNICHE

Per una corretta interpretazione di questo Catalogo vedere:
AVVERTENZE PER LA CONSULTAZIONE DEL CATALOGO (pag. 6)

Pour l'interprétation correcte de ce catalogue voyez:
REMARQUES POUR LA CONSULTATION DU CATALOGUE (page 7)

Um den Katalog genau lesen zu können, siehe:
HINWEISE ZUM GEBRAUCH DES KATALOGS (Seite 8)

For proper interpretation see:
USE OF THE CATALOG (page 9)

Para la correcta lectura del catálogo véase:
CÓMO SE MANEJA EL CATÁLOGO (pág. 10)

Tutti i diritti di riproduzione sono riservati alla FIAT S. p. A. Azienda AUTOBIANCHI - MILANO

Il sistema di numerazione che individua i singoli particolari elencati nel presente catalogo non può essere adottato in alcun caso, senza autorizzazione scritta dalla FIAT S. p. A. Azienda AUTOBIANCHI - MILANO

Tous droits réservés à la FIAT S. p. A. Azienda AUTOBIANCHI - MILANO

Le système de numérotation des pièces en liste dans ce Catalogue ne peut être adopté en aucun cas, sans une autorisation écrite de la FIAT S. p. A. Azienda AUTOBIANCHI - MILANO

Alle Urheberrechte sind von der FIAT S. p. A. Azienda AUTOBIANCHI - MILANO - vorbehalten

Die Benutzung des Numerierungssystems zur Kennzeichnung der im vorliegenden Katalog aufgeführten Ersatzteile bedarf in jedem Falle der schriftlichen Genehmigung der FIAT S. p. A. Azienda AUTOBIANCHI - MILANO

All rights reserved by FIAT S. p. A. Azienda AUTOBIANCHI - MILANO

Single item numeration method used in this catalog cannot be used without written consent by FIAT S. p. A. Azienda AUTOBIANCHI - MILANO

Reservados todos los derechos para FIAT S. p. A. Azienda AUTOBIANCHI - MILANO

El sistema de numeración de la piezas reseñadas en el catálogo no puede ser objeto de imitación o copia en ningún caso sin autorización por escrito de FIAT S. p. A. Azienda AUTOBIANCHI - MILANO

Stabilimento tipolitografico
G. CANALE & C. - 10137 TORINO

Copyright by FIAT S. p. A. Azienda AUTOBIANCHI - 20124 MILANO - Via F. Filzi, 24

Printed in Italy

S. A. T. - UFF. PUBBLICAZIONI TECNICHE

Stampato n. Imprimé N° Print No. | 603.82.038 - X-1968 - R. II-1971 - 1000
Druckschrift Nr. Impreso n°

Nota per gli Organizzati AUTOBIANCHI

Il presente Catalogo deve essere successivamente aggiornato, riportando a fianco di ciascuna parte interessata, sulle tavole e sugli elenchi, nella colonna « Modif. » il n. delle eventuali modifiche che verranno segnalate nel « Notiziario Tecnico » (N.T.).

Remarque pour le Réseau AUTOBIANCHI

Ce Catalogue devra être mis à jour en reportant à côté de chaque pièce concernée, sur les tableaux et les listes, dans la colonne « Modif. » (*modifications*) le numéro des modifications éventuelles qui seront signalées par le Bulletin Technique « Notiziario Tecnico » (N. T.).

Anmerkung für die AUTOBIANCHI-Dienststellen

Zur Berichtigung bzw. Vervollständigung vorliegenden Katalogs, sind auf den Bildtafeln und in der Ersatzteilliste und zwar in der Spalte « modif. » (*Änderungen*) neben dem betreffenden Ersatzteil die Kennnummern der eventuellen Änderungen, die in den Mitteilungsbättern « Notiziario Tecnico = N.T. » bekanntgegeben werden, aufzuführen.

Notice to AUTOBIANCHI Agents

This Catalog must be brought up-to-date by writing in line with the part involved — in the plates and in the column « Modif. » (*Modifications*) of part list — the Number identifying each Modification quoted in the Bulletin « Notiziario Tecnico » (N. T.).

Nota para los Organismos AUTOBIANCHI

El catálogo se pondrá al día apuntando en las láminas junto a los detalles afectados, y en la lista en el asiento que corresponde de la columna « Modif. » (= *modificaciones*), el número de las modificaciones de las que se irá dando parte en el « Notiziario Tecnico » (N.T.).

INDICE GENERALE	INDEX	VERZEICHNIS	CONTENTS	ÍNDICE GENERAL
<ul style="list-style-type: none"> — Norme per le ordinazioni . pag. 5 — Avvertenze per la consultazione del Catalogo » 6 — Elenco delle versioni (su carta arancione) » 11 — Validità dei Sottogruppi . . » 15 — Indice dei Sottogruppi . . . » 16 — Indice dei numeri d'ordinazione » 21 	<ul style="list-style-type: none"> — Commande de pièces détachées page 5 — Remarques pour la consultation du Catalogue » 7 — Liste des versions (sur papier orange). » 12 — Validité des Sousgroupes . . » 15 — Index des Sousgroupes . . . » 17 — Liste numérique » 21 	<ul style="list-style-type: none"> — Anweisungen zur Bestellung Seite 5 — Hinweise zum Gebrauch des Katalogs » 8 — Liste der Ausführungen (auf orangefarbigem Papier) . . » 12 — Gültigkeit der Untergruppen » 15 — Untergruppenverzeichnis . . » 18 — Nummernverzeichnis » 21 	<ul style="list-style-type: none"> — Ordering Parts page 5 — Use of the Catalog » 9 — Version List (on orange paper) » 13 — Subgroup Applicability . . . » 15 — Subgroup Index » 19 — Numerical Index » 21 	<ul style="list-style-type: none"> — Pedidos de repuestos pág. 5 — Cómo se maneja el catálogo » 10 — Lista de versiones (papel naranja) » 13 — Validez de los subgrupos . . » 15 — Índice de subgrupos » 20 — Índice numérico » 21
PARTI DI RICAMBIO	PIÈCES DÉTACHÉES	ERSATZTEILE	SPARE PARTS	PIEZAS DE REPUESTO
<ul style="list-style-type: none"> — Tavole da Sgr. A0.01 a Sgr. Z1.01 — Elenchi delle parti di Ricambio (Sul retro della tavola) 	<ul style="list-style-type: none"> — Planches du Sgr. A0.01 à Sgr. Z1.01 — Liste des pièces détachées (au verso des planches) 	<ul style="list-style-type: none"> — Bildtafeln von Utgr. A0.01 bis Z1.01 — Ersatzteilliste (auf der Rückseite der jeweiligen Bildtafel) 	<ul style="list-style-type: none"> — Plates Sgr. A0.01 to Sgr. Z1.01 — Spare Parts List (on the Plate sheet verso) 	<ul style="list-style-type: none"> — Láminas Sgrs. A0.01 a Z1.01 — Listas de piezas de repuesto (en el dorso de las láminas)
MODIFICHE	MODIFICATIONS	ÄNDERUNGEN	MODIFICATIONS	MODIFICACIONES
<ul style="list-style-type: none"> — Tabelle pag. 1M 	<ul style="list-style-type: none"> — Tableaux page 1M 	<ul style="list-style-type: none"> — Tabelle Seite 1M 	<ul style="list-style-type: none"> — Tables page 1M 	<ul style="list-style-type: none"> — Tablas pág. 1M
TABELLE VARIE	TABLEAUX DIVERS	VERSCHIEDENE TABELLEN	MISCELLANEA	TABLAS
<ul style="list-style-type: none"> — Parti di ricambio RIV . . . pag. 1T — Cavi per impianto elettrico » 3T — Capicorda e cappucci isolanti per cavi elettrici. » 4T 	<ul style="list-style-type: none"> — Pièces détachées RIV page 1T — Câbles électriques » 3T — Cosses et capuchons isolants pour câbles électriques . . » 4T 	<ul style="list-style-type: none"> — Ersatzteile RIV Seite 1T — Elektrische Leitungen . . . » 3T — Tabelle der Kabelschuhe und Schutzkappen » 4T 	<ul style="list-style-type: none"> — RIV Spares page 1T — Electrical cables » 3T — Electrical cable terminals and boots list » 4T 	<ul style="list-style-type: none"> — Piezas de recambio RIV pág. 1T — Cables eléctricos » 3T — Terminales y capuchones aislantes de cables eléctricos . . » 4T

NORME PER LE ORDINAZIONI

Le ordinazioni di parti di ricambio devono essere corredate dalle seguenti indicazioni:

- Modello e versione della vettura (*indicata nel foglio «Elenco delle Versioni», su carta arancione*)
- Tipo dell'autotelaio (1)
- Numero dell'autotelaio (2)
- Tipo del motore (3)
- Numero per ricambi (4) (*veicolo n. ...*)
- Numero del motore (*motore n. ...*)
- Numero di ordinazione della parte che si richiede (*come indicato nelle tavole e negli elenchi parti di ricambio*), in base al quale vengono evase le ordinazioni.

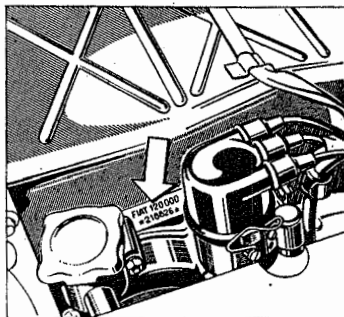
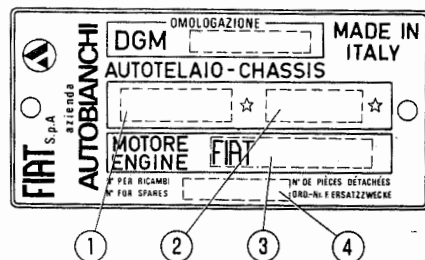

COMMANDE DE PIÈCES DÉTACHÉES

Les commandes doivent nous parvenir complètes des indications suivantes:

- Modèle et version de la voiture (*comme indiqué sur la feuille « Liste des Versions » sur papier orange*)
- Type du châssis (1)
- Numéro du châssis (2)
- Type du moteur (3)
- Numéro de pièces détachées (4) (*véhicule n° ...*)
- Numéro du moteur (*moteur n° ...*)
- Numéro de commande de la pièce requise (*comme indiqué sur les planches et aux listes des pièces*), d'après lequel les commandes sont expédiées.

ANWEISUNGEN ZUR BESTELLUNG

Bei Bestellung bitten wir stets folgendes anzugeben:

- Modell u. Ausführung des Wagens (*siehe « Liste der Ausführungen », auf orangefarbigem Papier*)
- Fahrgestell-Baumuster (1)
- Fahrgestell-Nummer (2)
- Motorbaumuster (3)
- Ordnungsnummer für Ersatzzwecke (4) (*Wagen Nr. ...*)
- Motornummer
- Bestellnummer des gewünschten Ersatzteils (*It. Bildtafeln u. Listen*), auf Grund derer die Lieferung erfolgt.

ORDERING PARTS

Orders for Spare Parts must include the following data:

- Car Model and Version (*as given on the « Version List » on orange paper*).
- Chassis Type (1)
- Chassis Number (2)
- Engine Type (3)
- Number for Spares (4) (*vehicle No. ...*)
- Engine Number
- Part Number of the ordered spare, as given on plates and lists, that will be used to fulfill the order.

PEDIDOS DE REPUESTOS

En todos los pedidos de piezas de repuesto tienen que consignarse los datos siguientes:

- modelo y versión del coche (*reseñados en la « Lista de Versiones », papel naranja*)
- modelo del chasis (1)
- matrícula del chasis (2)
- modelo del motor (3)
- número para recambios (4) (*vehículo n.º ...*)
- matrícula del motor (*motor n.º ...*)
- número de catálogo de la pieza requerida (*el que coincidirá con el reseñado en las listas de piezas de repuesto y en las láminas*), en base al cual se evacúa el pedido.

AVVERTENZE PER LA CONSULTAZIONE DEL CATALOGO

1 - Avvertenze generali per la consultazione.

Per la ricerca delle parti di ricambio illustrate ed elencate nel presente catalogo è necessario:

- a) consultare l'elenco delle versioni (su carta arancione) per individuare il codice numerico della versione base del veicolo in produzione che interessa;
- b) consultare l'indice « Validità dei sottogruppi » (su cartoncino, ripetuto anche a pag. 15) per conoscere le validità dei sottogruppi per le versioni base del veicolo.

2 - Tavole (da Sgr. A0.01 a Sgr. Z1.01).

Illustrano le parti di ricambio di ciascun sottogruppo. Ogni tavola riporta, in basso, il numero del sottogruppo (a destra) e l'eventuale numero di foglio, la denominazione del sottogruppo (al centro) e l'indicazione del modello (a sinistra).

Le parti di ricambio illustrate sono contraddistinte dal n. di ordinazione con a fianco tutte le indicazioni (modifiche, codici, ecc.) sufficienti in generale per poter individuare le parti stesse direttamente sulle tavole.

Indicazioni e abbreviazioni usate nelle tavole:

- 4072798** = parte di normale fornitura
873637-805338 = parti fornite in alternativa
4119705 (01) = parte propria della versione 01
980076 2,5 = parte avente spessore 2,5 mm
4119259 + 0,2 = parte maggiorata di 0,2 mm
4101758 = complessivo
4118204 A3.02 = complessivo le cui parti sono illustrate nel Sgr. A3.02
C 2180 4064081 = parte antemodifica* 2180 (viene ancora fornita di ricambio)
C 2184 4076009 = parte antemodifica 2184 (non viene più fornita di ricambio).
D 2180 4081948 = parte postmodifica 2180
A3.01 = parte illustrata nel Sgr. A3.01
1, 2, ecc. = vedere n. ordinazione nell'apposita tabella

- s** = parte sinistra (°)  = esistenza di «Serie», «Dotazioni», ecc.
d = parte destra (°)
Ø... = diametro ... mm

Validità della tavola

con la consultazione dell'indice « Validità dei Sottogruppi » di cui al punto 1 b;

C 2210 → **veic. n. 071115**

la tavola vale « fino » al veicolo con n. per ricambi 071115, in conseguenza della modifica 2210;

D 2210 veic. n. 071116 →

la tavola vale « dal » veicolo con n. per ricambi 071116, in conseguenza della modifica 2210.

3 - Elenchi delle parti di ricambio (sopra alle relative tavole).

Elencano le parti di ricambio di ciascun sottogruppo, illustrate nelle tavole e le parti fornite come « Serie » ecc. in ordine progressivo di n. di ordinazione.

Per una più completa interpretazione delle denominazioni delle parti di ricambio è opportuno riferirsi alle illustrazioni delle tavole.

Indicazioni e abbreviazioni usate negli elenchi :

- | | |
|-------------------------------|-------------------------------|
| Sgr. = Sottogruppo | ant. = anteriore (°) |
| N., n. = numero | post. = posteriore (°) |
| compl. = complessivo | sup. = superiore |
| sp. = spessore | inf. = inferiore |
| s = parte sinistra (°) | est. = esterno |
| d = parte destra (°) | int. = Interno |
| R.M. = retromarcia | lat. = laterale |
- 1a, 2a, ...** = 1a, 2a, ... velocità
m = fornito a metri
T = ved. « Tabelle varie »
S = esistenza di « Serie » ecc. } *nella colonna « quant. »*

4 - Tabelle « Modifiche ».

Elencano tutte le modifiche apportate ai veicoli durante il corso della produzione, le loro applicazioni (con una eventuale illustrazione complessiva della modifica, quando si ritiene necessario) e le norme di ricambio.

(°) Rispetto alla direzione di marcia del veicolo.

Indicazioni e abbreviazioni usate nelle tabelle modifiche:

colonna « Modifica »:

- C ...** = modifica n... (per le parti antemodifica)
D ... = modifica n... (per le parti postmodifica)

attuazioni:

- **veic. n. ...** = « fino » al veicolo con n. per ricambi...
 → **mot. n. ...** = « fino » al motore n. ...
veic. n. ... → = « dal » veicolo con n. per ricambi...
mot. n. ... → = « dal » motore n. ...
IX 1964 = nel mese di settembre 1964

colonna « Sgr. interessati e Norme di ricambio »:

- C1.30-C1.32** = sottogruppi interessati alla modifica
(N. T. ...) = n. del Notiziario Tecnico con il quale viene segnalata la modifica

norme di ricambio:

- ~~**4055118**~~ = D 2072
 ad esaurimento scorte 4055118 applicare tutte le parti postmodifica D 2072.
4055102 = 4089698
 ad esaurimento scorte 4055102 sostituire con 4089698.
4076308 = 4086486 + 4092472
 ad esaurimento scorte 4076308, sostituire con 4086486 e 4092472.
~~**4066205**~~ = 4082585 — (4074547 + 4074548)
 ad esaurimento scorte 4066205 sostituire con 4082585 eliminando 4074547 e 4074548.

5 - « Tabelle varie ».

Comprendono le tabelle da consultare per conoscere i dati relativi alle « Parti di ricambio RIV », ai « Cavi per impianti elettrici », ai « Capi-corda e cappucci isolanti per cavi elettrici ».

HINWEISE ZUM GEBRAUCH DES KATALOGS

1 - Allgemeine Hinweise für den Gebrauch.

Zum Auffinden der in vorliegendem Katalog aufgeführten und abgebildeten Ersatzteile ist notwendig:

- die **Liste der Ausführungen** (auf orangefarbigem Papier) nachzuschlagen, um die **Kennummer** der Grundauführung des in Frage kommenden Fahrzeugs festzustellen.
- das Verzeichnis « **Gültigkeit der Untergruppen** » (auf Karton, auf S. 15 wiederholt) nachzuschlagen, um die Zugehörigkeit der Untergruppen zu den einzelnen Grundauführungen festzustellen.

2 - Bildtafeln (von Utgr. A0.01 bis Z1.01).

Die Tafeln veranschaulichen die Ersatzteile jeder einzelnen Untergruppe.

Auf jeder Bildtafel ist folgendes angegeben: die **Untergruppennummer** (rechts) mit der eventuellen Seitennummer des Katalogblatts, die **Untergruppenbenennung** (in der Mitte), sowie **Wagenmodell** (links).

Die abgebildeten Ersatzteile sind mit den **Bestellnummern** und sämtlichen Angaben versehen (**Änderungen**, **Kennummern** usw.), die im allgemeinen ausreichen, die gewünschten Teile direkt auf den Bildtafeln zu ermitteln.

Erläuterungen und Abkürzungen auf den Bildtafeln:

- 4072798** = normalweise gelieferter Teil
873637-805338 = abwechselnd gelieferter Teil
4119705 (01) = Eigenteil der Ausführung 01
980076 2,5 = Teil 2,5 mm stark
4119259 + 0,2 = Teil mit 0,2 mm Übermass
4101758 = Zusammenbau
4118204 A3.02 = Zusammenbau dessen Einzelteile in Utgr. A3.02 abgebildet sind
C 2180 4064081 = früherer Teil 2180 (wird weiterhin geliefert)
C 2184 4076009 = früherer Teil 2184 (nicht mehr erhältlich)
D 2180 4081948 = gegenwärtiger Teil 2180

A3.01 = in Utgr. A3.01 abgebildeter Teil

1, 2, usw. = s. Bestellnr. in der speziellen Tabelle

s = links (°)

d = rechts (°)

∅... = ... mm Durchmesser



= Lieferbarkeit von Teilen als «Satz», «Serie», usw.

Gültigkeit der Bildtafeln:

durch Nachschlagen des Verzeichnisses « **Gültigkeit der Untergruppen** », wie in Punkt 1 b angegeben.

C 2210 → **veic. n. 071115**

die Tafel gilt « bis » Wagen mit Ordnungs-nr. f. Ersatzzwecke 071115 infolge der Änderung 2210;

D 2210 veic. n. 071116 →

die Tafel gilt « ab » Wagen mit Ordnungs-nr. f. Ersatzzwecke 071116 infolge der Änderung 2210.

3 - Ersatzteilliste (oberhalb der jeweiligen Bildtafel).

Die Listen führen die in den Bildtafeln abgebildeten und die als « Satz » gelieferten Ersatzteile in **laufender Bestellnummernfolge** an.

Zur besseren Verständigung der **Benennung** der einzelnen Ersatzteile, siehe Bildtafeln.

Erläuterungen und Abkürzungen auf den Ersatzteillisten (im italienischen Teil).

- | | |
|-----------------------------|---------------------------|
| Sgr. = Untergruppe | ant. = vorn (°) |
| N., n. = Nummern | post. = hinten (°) |
| compl. = Zusammenbau | sup. = oben |
| sp. = Stärke | inf. = unten |
| s = links (°) | est. = aussen |
| d = rechts (°) | int. = innen |
| R.M. = Rückwärtsgang | lat. = seitlich |
-
- | | |
|--|-----------------------------------|
| 1a, 2a, ... = 1., 2., ... Gang | } in der Spalte «quant.» (Anzahl) |
| m = vom laufenden Meter erhältlich | |
| T = siehe «Tabelle varie» (verschiedene Tabellen) | |
| S = Vorhandensein von «Sätzen», usw. | |

4 - Abschnitt « Änderungen ».

In diesem Abschnitt sind sämtliche im Laufe der Produktion an den Fahrzeugen vorgenommene **Änderungen** sowie ihre **Einführung** (mit einer eventuellen, falls für notwendig gefundenen Gesamtabbildung der Änderung) und **Ersatzanweisungen** aufgeführt.

(°) in Bezug auf die Fahrtrichtung des Fahrzeugs.

Hinweise und Abkürzungen in der Tabelle Änderungen:

Spalte « **Modifica** » (Änderung):

C ... = Änderungsnummer ... (frühere Teile)

D ... = Änderungsnummer ... (gegenwärtige Teile)

Einführung:

→ **veic. n. ...** = « bis » Wagen mit Ordnungs-nr. f. Ersatzzwecke ...

→ **mot. n. ...** = « bis » Motor Nr. ...

veic. n. ... → = « ab » Wagen mit Ordnungs-nr. f. Ersatzzwecke ...

mot. n. ... → = « ab » Motor Nr. ...

IX 1964 = September 1964

Spalte « **Sgr. interessati e Norme di ricambio** » (betreffende Untergruppen und Ersatzanweisung):

C1.30-C1.32 = die Änderung betreffende Untergruppen

(**N. T. ...**) = « Technisches Mitteilungsblatt » in welchem die Änderung beschrieben ist.

Ersatzanweisung:

4055118 = D 2072

nach Aufbrauch der Nr. 4055118, sämtliche neuen Teile D 2072 einbauen

4055102 = **4089698**

nach Aufbrauch der Nr. 4055102 durch 4089698 ersetzen

4076308 = **4086486** + **4092472**

nach Aufbrauch der Nr. 4076308 durch 4086486 und 4092472 ersetzen

4066205 = **4082585** — (**4074547** + **4074548**)

nach Aufbrauch der Nr. 4066205 durch 4082585 ersetzen, wobei 4074547 und 4074548 zu entfernen sind.

5 - Verschiedene Tabellen.

Dieser Teil enthält die Tabellen, in denen die Daten betreffs der « Ersatzteile RIV », der « elektrischen Leitungen » und der « Kabelschuhe und Schutzkappen » zusammengefasst sind.

USE OF THE CATALOG

1 - Using the Catalog.

To find the spares shown and listed in the catalog proceed as follows:

- Consult the "**Version List**", on orange paper, to find the **code number** of the current production vehicle basic version concerned;
- Consult the "**Subgroup Applicability**", index (on cardboard, reported also on page 15) to identify the applicability of subgroups for the vehicle basic versions.

2 - Plates (Sgr. A0.01 to Sgr. Z1.01).

Illustrations show the spare parts of each subgroup. Below each Plate there is the **Sgr. No.** (right) and sheet number, if any, the **Sgr. title** (center), and the **Model indication** (left).

The spare parts illustrated are identified by respective **Part Numbers** together with other indications (*modifications, codes, etc.*) generally sufficient for direct location of parts on Plate.

Indications and abbreviations used in the Plates:

- 4072798** = Standard supply part
873637-805338 = Parts supplied as an alternative
4119705 (01) = Part specific for version 01
980076 2,5 = 2,5 mm thick part
4119259+0,2 = 0,2 mm o/s part
4101758 = Assembly
4118204 A3.02 = Assembly whose separate components are shown in Sgr. A3.02
 C 2180 **4064081** = Ante-modification 2180 part (*supply is continued*)
 C 2184 **4076009** = Ante-modification 2184 part (*supply has been discontinued*)
 D 2180 **4081948** = Post-modification 2180 part
A3.01 = Part shown in Sgr. A3.01
1, 2, etc. = see Part. No. in the specific list

s = Left (°)

d = Right (°)

∅ ... = ... mm dia.



= Some parts are supplied as « Set », « Kit », etc.

Plate applicability

Consulting the index « **Subgroup Applicability** » as referred in para 1 b.

C 2210 → **veic. n. 071115**

Consequently to modification 2210 the plate is valid up to vehicle with Number for Spares 071115;

D 2210 **veic. n. 071116** →

Consequently to modification 2210 the plate is valid from vehicle with Number for Spares 071116.

3 - Spare Parts List (facing relevant Plates).

List the spare parts, and the parts supplied as « set », « kit », etc. of each subgroup, illustrated in the plates according to the **progressive Part Number**.

Refer to plate illustrations for a complete interpretation of spare **description**.

Indications and abbreviations used in the lists (*only in the Italian section*):

Sgr. = Subgroup

N., n. = number

compl. = assembly

sp. = thickness

s = left (°)

d = right (°)

R.M. = reverse

ant. = front (°)

post. = rear (°)

sup. = upper

inf. = lower

est. = outer

int. = inner

lat. = side

1a, 2a, ... = 1st, 2nd ... gear

m = supplied by the meter

T = see "Tabelle varie" (*miscellanea*)

S = some parts are supplied as "quant"

"Kit" "Set" etc.

} Column

"quant"

4 - "Modifications" Tables.

List all the **modifications** introduced on vehicles during the production, their **applicability** (*when necessary, shows also a complete illustration of the modification as a whole*) and the **directions for replacement**.

(°) *Determined by facing in the same direction as the driver.*

Indications and abbreviations used in modification tables:

Column "**Modifica**" (*Modification*):

C ... = modification No. ... (*for the A.M. parts*)

D ... = modification No. ... (*for the P.M. parts*)

effectiveness:

→ **veic. n. ...** = up to vehicle with Number for Spares ...

→ **mot. n. ...** = up to engine No. ...

veic. n. ... → = from vehicle with Number for Spares ...

mot. n. ... → = from engine No. ...

IX 1964 = introduced in September 1964

Column "**Sgr. interessati e Norme di ricambio**" (*Sgr. involved and directions for replacement*):

C1.30-C1.32 = Subgroups involved in the modification

(**N. T. ...**) = number of the « Technical Bulletin » in which the modification is described.

Directions for replacement:

~~4055110~~ = D 2072

On exhaustion of stocks of 4055118 mount all P. M. D 2072 parts

~~4055102~~ = 4089698

On exhaustion of stocks of 4055102 replace with 4089698

~~4076308~~ = 4086486 + 4092472

On exhaustion of stocks of 4076308 replace with 4086486 and 4092472

~~4066205~~ = 4082585 — (4074547 + 4074548)

On exhaustion of stocks of 4066205 replace with 4082585, discarding 4074547 and 4074548.

5 - Miscellanea.

This Section includes the list showing data relevant to RIV Spares, Electrical cables, Insulating Boots and Terminals.

CÓMO SE MANEJA EL CATÁLOGO

1 - Normas generales.

Para buscar las piezas de repuesto ilustradas y reseñadas en el catálogo, hay que:

- conocer el **código** de las versiones del vehículo que interesa, el que figura en la **lista de versiones (papel naranja)**;
- conocer la validez de los subgrupos en relación a las versiones del vehículo, deduciéndola de la tabla « **Validez de los subgrupos** » (papel cartulina y pág. 15).

2 - Láminas (subgrupos A0.01 a Z1.01).

Representan las piezas de recambio de cada subgrupo. Al pie de cada hoja, tenemos: *en la parte derecha*, el **número del subgrupo** y el número de la hoja (*eventual*); *en el centro*, la **denominación del subgrupo**, y *en la parte izquierda* el **modelo**.

Cada pieza de recambio representada lleva el **número de catálogo** acompañado de todas las indicaciones (*modificaciones, códigos, etc.*), que generalmente son suficientes para reconocer la misma pieza en la lámina.

Notaciones y abreviaturas usadas en las láminas:

4072798	= pieza de suministro normal
873637-805338	= piezas de suministro alternativo
4119705 (01)	= pieza propia de la versión 01
980076 2,5	= pieza de 2,5 mm de grueso
4119259 + 0,2	= pieza de 0,2 mm sobremedida
4101758	= conjunto
4118204 A3.02	= conjunto cuyo despiece se ilustra en el Sgr. A3.02
C 2180 4064081	= pieza anterior a la modificación 2180 (<i>de la que se suministran aún recambios</i>)
C 2184 4076609	= pieza anterior a la modificación 2184 (<i>de la que no se dan más recambios</i>)
D 2180 4081948	= pieza posterior a la modificación 2180
A3.01	= pieza ilustrada en el Sgr. A3.01
1, 2, etc	= véase el n.º de pedido en la propia tabla

s = parte izquierda (°)
d = parte derecha (°)
 Ø... = diámetro en mm



= de algunas piezas se suministran « **Juegos** », etc.

Validez de la lámina

se deduce de la tabla « **Validez de los subgrupos** » citada en el punto 1 b;

C 2210 → veic. n. 071115

la lámina es aplicable « hasta » el vehículo con número para recambios 071115, por efecto de la modificación 2210;

D 2210 veic. n. 071116 →

la lámina es aplicable « a partir del » vehículo con número para recambios 071116, por efecto de la modificación 2210.

3 - Listas de piezas de repuesto (arriba de cada lámina).

Comprenden las piezas de repuesto de cada subgrupo ilustradas en las láminas y las piezas incluidas en « juegos » etc., y reseñadas según el **orden progresivo del número de catálogo**.

Para comprender mejor las **denominaciones** de las piezas de repuesto es oportuno mirar las ilustraciones de las láminas.

Notaciones y abreviaturas usadas en la lista *en lengua italiana*:

Sgr.	= subgrupo	ant.	= anterior (°)
N., n.	= número	post.	= posterior (°)
compl.	= conjunto	sup	= superior
sp.	= espesor, grueso	inf.	= inferior
s	= parte izquierda (°)	est.	= exterior
d	= parte derecha (°)	int.	= interior
R.M.	= marcha atrás	lat.	= lateral
1a, 2a, ...	= 1a., 2a. ... velocidades		
m	= se suministra por metros		
T	= véanse « <i>Tabelle varie</i> »		
S	= existencia de « <i>Juegos</i> », etc.		

} *en la columna « quant. » (= cantidad)*

4 - Tablas « Modificaciones ».

Comprenden todas las **modificaciones** habidas en los vehículos durante su fabricación, **cómo se incorporaron** (y cuando se estime bien, la **ilustración general de la modificación**) y las **normas para los recambios**.

(°) *Respecto de la dirección de la marcha del vehículo.*

Notaciones y abreviaturas usadas en las tablas de modificaciones:

columna « **Modifica** » (= *modificaciones*):

C ... = modificación núm. (*para las piezas antiguas*)

D ... = modificación núm. ... (*para las piezas nuevas*)

incorporación:

→ **veic. n. ...** = « hasta » el vehículo con núm. para recambios ...

→ **mot. n. ...** = « hasta » el motor con núm. ...

veic. n. ... → = « a partir » del vehículo con núm. para recambios ...

mot. n. ... → = « a partir » del motor con núm. ...

IX 1964 = en el mes de septiembre de 1964

columna « **Sgr. interessati e Norme di ricambio** » (= *subgrupos afectados por la modificación y normas para los recambios*):

C1.30 - C1.32 = subgrupos afectados por la modificación;

(N. T. ...) = núm. del « *Boletín técnico* » en el que se da parte de la modificación habida.

normas para los recambios:

4055118 = D 2072

al agotarse las existencias de 4055118, colóquense todas las piezas D 2072

4055102 = 4089698

al agotarse las existencias de 4055102, colóquese 4089698

4076308 = 4086486 + 4092472

al agotarse las existencias de 4076308, colóquese 4086486 y 4092472

4066205 = 4082585 — (4074547 + 4074548)

al agotarse las existencias de 4066205, colóquese 4082585 anulando 4074547 y 4074548.

5 - Tablas.

Se reseñan los datos referentes a piezas de recambio RIV, cables, eléctricos, terminales y capuchones aislantes de cables eléctricos.

ELENCO DELLE VERSIONI

Versioni base:		Codici numerici
Bianchina Panoramica	(Tipo 120 B) con guida sinistra	01
Bianchina Panoramica	(Tipo 120 B) con guida destra	02
Bianchina Furgoncino	(Tipo 264) con guida sinistra	03
Bianchina Furgoncino	(Tipo 264) con guida destra	04
Bianchina Furgoncino 320/2	(Tipo 264 E) con guida sinistra	05
Bianchina Furgoncino 320/2	(Tipo 264 E) con guida destra	06
Bianchina Giardiniera	(Tipo 120) con guida sinistra	07
Bianchina Giardiniera	(Tipo 120) con guida destra	08

Versioni particolari:

per circolazione a sinistra	11
per Germania	12
per Francia e Belgio	13
per zone tropicali	14
per Inghilterra e Irlanda	15
Bianchina Panoramica Lusso	16
Bianchina Giardiniera per Danimarca - Svezia - Finlandia - Norvegia - Inghilterra - Germania - Svizzera	17
Bianchina Giardiniera con presa per lampada portatile	18

NOTA - Le validità delle tavole e degli elenchi delle parti di ricambio per le varie versioni base sono indicati sull'indice « Validità dei Sottogruppi » (pag. 15) con i codici numerici delle versioni base.

Le limitazioni di validità delle singole parti di ricambio rispetto alla validità dell'intera tavola, sono indicate con i codici numerici delle versioni base o delle versioni particolari riportati, fra parentesi, a fianco del n. di ordinazione.

LISTE DES VERSIONS

Versions-base:		Codes numériques
Bianchina Panoramica	(Type 120 B) conduite à gauche	01
Bianchina Panoramica	(Type 120 B) conduite à droite	02
Bianchina Fourgonnette	(Type 264) conduite à gauche	03
Bianchina Fourgonnette	(Type 264) conduite à droite	04
Bianchina Fourgonnette 320/2	(Type 264 E) conduite à gauche	05
Bianchina Fourgonnette 320/2	(Type 264 E) conduite à droite	06
Bianchina Jardinière	(Type 120) conduite à gauche	07
Bianchina Jardinière	(Type 120) conduite à droite	08

Versions spéciales:

pour circulation à gauche	11
pour l'Allemagne	12
pour la France et la Belgique	13
pour les zones tropicales	14
pour l'Angleterre et l'Irlande	15
Bianchina Panoramica de Luxe	16
Bianchina Jardinière pour le Danemark - la Suède - la Finlande - la Norvège - l'Angleterre - l'Allemagne - la Suisse	17
Bianchina Jardinière avec prise pour baladeuse	18

NOTA - Les validités des planches et des listes de pièces détachées des différentes versions-base sont indiquées dans l'index « Validité des Sousgroupes » (page 15) avec les codes numériques des versions-base.

Les limitations de validité de chaque pièce détachée par rapport à la validité de la planche entière, sont indiquées par les codes numériques des versions-base ou des versions spéciales figurant, entre parenthèses, à côté du n. de commande.

LISTE DER AUSFÜHRUNGEN

Grundausführungen:		Kennnummern
Bianchina Panorama	(Typ 120 B) Linkslenkung	01
Bianchina Panorama	(Typ 120 B) Rechtslenkung	02
Bianchina Lieferwagen	(Typ 264) Linkslenkung	03
Bianchina Lieferwagen	(Typ 264) Rechtslenkung	04
Bianchina Lieferwagen 320/2	(Typ 264 E) Linkslenkung	05
Bianchina Lieferwagen 320/2	(Typ 264 E) Rechtslenkung	06
Bianchina Kombiwagen	(Typ 120) Linkslenkung	07
Bianchina Kombiwagen	(Typ 120) Rechtslenkung	08

Spezialausführungen:

für Linksverkehr	11
für Deutschland	12
für Frankreich und Belgien	13
für Tropenländer	14
für England und Irland	15
Bianchina Panoramica Luxus	16
Bianchina Kombiwagen für Dänemark, Schweden, Finnland, Norwegen, England, Deutschland, Schweiz	17
Bianchina Kombiwagen mit Steckanschluss für Handleuchte	18

ANMERKUNG - Die Zugehörigkeit der Bildtafeln und der Ersatzteillisten zu den einzelnen Grundausführungen geht aus dem Verzeichnis "Gültigkeit der Untergruppen" (s. S. 15) durch die entsprechenden Kennnummern hervor.

Ist neben der Bestellnummer die eingeklammerte Kennnummer einer Grund- oder Spezialausführung angeführt, dann bedeutet das, dass Teil ausschliesslich dieser Ausführung angehört.

VERSION LIST

Basic versions:

Code No.

Bianchina Panoramica	(Type 120 B) LHD	01
Bianchina Panoramica	(Type 120 B) RHD	02
Bianchina Van	(Type 264) LHD	03
Bianchina Van	(Type 264) RHD	04
Bianchina Van 320/2	(Type 264 E) LHD	05
Bianchina Van 320/2	(Type 264 E) RHD	06
Bianchina Station Wagon	(Type 120) LHD	07
Bianchina Station Wagon	(Type 120) RHD	08

Special versions:

for Left-hand traffic countries	11
for export to Germany	12
for export to France and Belgium	13
for tropical climates	14
for export to Great Britain and Ireland	15
De Luxe Bianchina Panoramica	16
Bianchina Station Wagon for export to Denmark - Sweden - Finland - Norway - Great Britain - Germany - Switzerland	17
Bianchina Station Wagon with inspection lamp receptacle	18

NOTE - The applicability of the Plates and the Parts Lists for the different basic versions are indicated in the « Subgroup Applicability » index (page 15) along with the basic version Code Nos.

Limitations to applicability of single spares, if any, with respect to the applicability of the Plates as a whole are marked off by parenthe-sized Code Nos. of the basic or Special version affixed to the Part. No.

LISTA DE VERSIONES

Versiones básicas:

Códigos

Bianchina Panoramica	(Tipo 120 B) conducción izquierda	01
Bianchina Panoramica	(Tipo 120 B) conducción derecha	02
Bianchina Furgoneta	(Tipo 264) conducción izquierda	03
Bianchina Furgoneta	(Tipo 264) conducción derecha	04
Bianchina Furgoneta 320/2	(Tipo 264 E) conducción izquierda	05
Bianchina Furgoneta 320/2	(Tipo 264 E) conducción derecha	06
Bianchina Comercial	(Tipo 120) conducción izquierda	07
Bianchina Comercial	(Tipo 120) conducción derecha	08

Versiones especiales:

para circulación por la izquierda	11
para Alemania	12
para Francia y Bélgica	13
para climas tropicales	14
para Inglaterra e Irlanda	15
Bianchina Panoramica Lujo	16
Bianchina Comercial para Dinamarca, Suecia, Finlandia, Inglaterra, Alemania e Suiza	17
Bianchina Panoramica con enchufe para lámpara portátil	18

NOTA - La validez de las láminas y las listas de las piezas de repuesto de las versiones básicas se expresan por los números de código de las versiones básicas en la tabla « Validez de los subgrupos » (pág. 15).

Los números de código entre paréntesis que acompañan al número de catálogo de una pieza de repuesto, limitan la validez de esa pieza, respecto a la de toda la lámina, a la versión básica, o bien especial, expresada por el número de código reseñado.

Bianchina Panoramica e derivati - **VALIDITÀ DEI SOTTOGRUPPI**

Validité des Sousgroupes
Gültigkeit der Untergruppen

Subgroup Applicability
Validez de los subgrupos

*

Sgr.	01	02	03	04	05	06	07	08	Sgr.	01	02	03	04	05	06	07	08	Sgr.	01	02	03	04	05	06	07	08	Sgr.	01	02	03	04	05	06	07	08									
A0.01	=	=	=	=	=	=	=	=	B2.04	=	=	=	=	=	=	=	=	D3.16	=	=	=	=	=	=	=	=	F6.29/1	=	=	=	=	=	=	=	=	F6.65	=	=	=	=	=	=	=	=
A1.01	=	=	=	=	=	=	=	=	B2.07	=	=	=	=	=	=	=	=	E1.01	=	=	=	=	=	=	=	=	F6.29/2	=	=	=	=	=	=	=	=	Z1.01	=	=	=	=	=	=	=	=
A1.02	=	=	=	=	=	=	=	=	B2.10	=	=	=	=	=	=	=	=	E3.01	=	=	=	=	=	=	=	=	F6.29/3	=	=	=	=	=	=	=	=									
A1.03	=	=	=	=	=	=	=	=	B2.24	=	=	=	=	=	=	=	=	E3.01/1	=	=	=	=	=	=	=	=	F6.29/4	=	=	=	=	=	=	=	=									
A1.05	=	=	=	=	=	=	=	=	B4.01	=	=	=	=	=	=	=	=	E3.01/2	=	=	=	=	=	=	=	=	F6.29/5	=	=	=	=	=	=	=	=									
A1.06	=	=	=	=	=	=	=	=	B4.04	=	=	=	=	=	=	=	=	F1.01	=	=	=	=	=	=	=	=	F6.29/6	=	=	=	=	=	=	=	=									
A1.07	=	=	=	=	=	=	=	=	C1.01	=	=	=	=	=	=	=	=	F2.01	=	=	=	=	=	=	=	=	F6.29/7	=	=	=	=	=	=	=	=									
A2.01	=	=	=	=	=	=	=	=	C1.01/1	=	=	=	=	=	=	=	=	F3.01	=	=	=	=	=	=	=	=	F6.29/9	=	=	=	=	=	=	=	=									
A2.02	=	=	=	=	=	=	=	=	C1.02	=	=	=	=	=	=	=	=	F4.01	=	=	=	=	=	=	=	=	F6.29/10	=	=	=	=	=	=	=	=									
A2.03	=	=	=	=	=	=	=	=	C1.02/1	=	=	=	=	=	=	=	=	F4.01/1	=	=	=	=	=	=	=	=	F6.29/11	=	=	=	=	=	=	=	=									
A2.03/1	=	=	=	=	=	=	=	=	C1.06	=	=	=	=	=	=	=	=	F4.01/2	=	=	=	=	=	=	=	=	F6.29/12	=	=	=	=	=	=	=	=									
A2.04	=	=	=	=	=	=	=	=	C1.07	=	=	=	=	=	=	=	=	F4.01/3	=	=	=	=	=	=	=	=	F6.29/13	=	=	=	=	=	=	=	=									
A2.05	=	=	=	=	=	=	=	=	C1.30	=	=	=	=	=	=	=	=	F5.01	=	=	=	=	=	=	=	=	F6.29/14	=	=	=	=	=	=	=	=									
A2.06	=	=	=	=	=	=	=	=	C1.32	=	=	=	=	=	=	=	=	F5.03	=	=	=	=	=	=	=	=	F6.32	=	=	=	=	=	=	=	=									
A2.21	=	=	=	=	=	=	=	=	C1.35	=	=	=	=	=	=	=	=	F5.03/1	=	=	=	=	=	=	=	=	F6.32/1	=	=	=	=	=	=	=	=									
A2.56	=	=	=	=	=	=	=	=	D2.01	=	=	=	=	=	=	=	=	F5.05	=	=	=	=	=	=	=	=	F6.34	=	=	=	=	=	=	=	=									
A3.01	=	=	=	=	=	=	=	=	D2.02	=	=	=	=	=	=	=	=	F6.02	=	=	=	=	=	=	=	=	F6.34/1	=	=	=	=	=	=	=	=									
A3.01/1	=	=	=	=	=	=	=	=	D2.10	=	=	=	=	=	=	=	=	F6.02/1	=	=	=	=	=	=	=	=	F6.34/2	=	=	=	=	=	=	=	=									
A4.07	=	=	=	=	=	=	=	=	D3.01	=	=	=	=	=	=	=	=	F6.06	=	=	=	=	=	=	=	=	F6.34/3	=	=	=	=	=	=	=	=									
A4.09	=	=	=	=	=	=	=	=	D3.05	=	=	=	=	=	=	=	=	F6.08	=	=	=	=	=	=	=	=	F6.34/4	=	=	=	=	=	=	=	=									
B1.01	=	=	=	=	=	=	=	=	D3.10	=	=	=	=	=	=	=	=	F6.14	=	=	=	=	=	=	=	=	F6.35	=	=	=	=	=	=	=	=									
B1.05	=	=	=	=	=	=	=	=	D3.10/1	=	=	=	=	=	=	=	=	F6.14/1	=	=	=	=	=	=	=	=	F6.35/1	=	=	=	=	=	=	=	=									
B2.01	=	=	=	=	=	=	=	=	D3.14	=	=	=	=	=	=	=	=	F6.29	=	=	=	=	=	=	=	=	F6.35/2	=	=	=	=	=	=	=	=									

* Codici delle versioni base.
= Vale il sottogruppo della colonna Sgr.

* Codes des versions-base.
= Le sousgroupe valable est celui indiqué à la colonne « Sgr. ».

* Kennnummern der Grundausführungen.
= Die Untergruppen sind in der Spalte « Sgr. » angegeben.

* Basic version codes.
= Applicable Subgroup is shown in the « Sgr. » column.

* Códigos de las versiones básicas.
= Aplicable el subgrupo de la columna « Sgr. ».

INDICE DEI SOTTOGRUPPI

<p style="text-align: center;">A - MOTORE</p> <p>Gruppo A0 - Complessivo motore</p> <p>Sgr. A0.01 - Motore e supporti gruppo motopropulsore.</p> <p>Gruppo A1 - Organi principali</p> <p>Sgr. A1.01 - Basamento e testa cilindri. » A1.02 - Coppa e coperchi basamento. » A1.03 - Albero e volano motore. » A1.05 - Bielle e stantuffi. » A1.06 - Comando distribuzione. » A1.07 - Distribuzione.</p> <p>Gruppo A2 - Alimentazione e scarico</p> <p>Sgr. A2.01 - Serbatoio combustibile e tubazioni. » A2.02 - Pompa alimentazione e tubazioni. » A2.03 - Pompa alimentazione. » A2.04 - Carburatore e filtro aria. » A2.05 - Filtro aria. » A2.06 - Carburatore. » A2.21 - Comandi acceleratore e carburatore. » A2.56 - Tubazione di scarico.</p> <p>Gruppo A3 - Lubrificazione</p> <p>Sgr. A3.01 - Lubrificazione.</p>	<p style="text-align: center;">Gruppo A4 - Raffreddamento</p> <p>Sgr. A4.07 - Prese aria e convogliatore. » A4.09 - Ventilatore.</p> <p style="text-align: center;">B - TRASMISSIONE</p> <p style="text-align: center;">Gruppo B1 - Innesto</p> <p>Sgr. B1.01 - Comando disinnesto frizione. » B1.05 - Frizione (parti).</p> <p style="text-align: center;">Gruppo B2 - Cambio</p> <p>Sgr. B2.01 - Cambio e differenziale, scatola e coperchi. » B2.04 - Ruotismi cambio di velocità. » B2.07 - Comandi esterni cambio di velocità. » B2.10 - Comandi interni cambio di velocità. » B2.24 - Segnalazione velocità e comando.</p> <p style="text-align: center;">Gruppo B4 - Ponti</p> <p>Sgr. B4.01 - Semialberi differenziale. » B4.04 - Ruotismi riduzione e differenziale.</p>	<p style="text-align: center;">C - FRENI</p> <p style="text-align: center;">Gruppo C1 - Freni sulle ruote</p> <p>Sgr. C1.01 - Comando a pedale freni. » C1.02 - Comando idraulico freni. » C1.06 - Cilindro maestro. » C1.07 - Cilindro comando gancie. » C1.30 - Freni ruote anteriori. » C1.32 - Freni ruote posteriori. » C1.35 - Comando a mano freni.</p> <p style="text-align: center;">D - STERZO, SOSPENSIONI E RUOTE</p> <p style="text-align: center;">Gruppo D2 - Sterzo</p> <p>Sgr. D2.01 - Comando sterzo. » D2.02 - Scatola sterzo. » D2.10 - Tiranteria comando sterzo.</p> <p style="text-align: center;">Gruppo D3 - Sospensioni e ruote</p> <p>Sgr. D3.01 - Sospensione anteriore. » D3.05 - Sospensione posteriore. » D3.10 - Ammortizzatori (D3.10, D3.10(1)). » D3.14 - Fuso a snodo. » D3.16 - Ruote.</p>	<p style="text-align: center;">E - ORGANI SUSSIDIARI</p> <p style="text-align: center;">Gruppo E1 Riscaldamento e ventilazione interno vettura</p> <p>Sgr. E1.01 - Riscaldamento aria.</p> <p style="text-align: center;">Gruppo E3 - Vari</p> <p>Sgr. E3.01 - Lavacrystallo.</p> <p style="text-align: center;">F - IMPIANTO ELETTRICO</p> <p style="text-align: center;">Gruppo F1 - Accensione</p> <p>Sgr. F1.01 - Accensione motore.</p> <p style="text-align: center;">Gruppo F2 - Avviamento</p> <p>Sgr. F2.01 - Avviamento motore.</p> <p style="text-align: center;">Gruppo F3 - Generatore</p> <p>Sgr. F3.01 - Generazione di corrente.</p> <p style="text-align: center;">Gruppo F4 - Illuminazione</p> <p>Sgr. F4.01 - Illuminazione esterna ed interna.</p>	<p style="text-align: center;">Gruppo F5 - Accessori</p> <p>Sgr. F5.01 - Segnalazione di avviso e di manovra. » F5.03 - Segnalazioni di funzionamento. » F5.05 - Accessori vari.</p> <p style="text-align: center;">Gruppo F6 - Parti di apparecchi</p> <p>Sgr. F6.02 - Dinamo. » F6.06 - Gruppo di regolazione. » F6.08 - Motorino di avviamento. » F6.14 - Distributore di accensione » F6.29 - Proiettori. » F6.32 - Fanali anteriori. » F6.34 - Fanali posteriori. » F6.35 - Fanale targa. » F6.65 - Tergicristallo.</p> <p style="text-align: center;">Z - DOTAZIONI</p> <p style="text-align: center;">Gruppo Z1 - Attrezzi</p> <p>Sgr. Z1.01 - Attrezzi.</p>
--	--	---	---	--

INDEX DES SOUSGROUPES

<p>A - MOTEUR</p> <p>Groupe A0 - Ensemble moteur</p> <p>Sgr. A0.01 - Moteur et supports du groupe propulseur.</p> <p>Groupe A1 - Organes principaux</p> <p>Sgr. A1.01 - Bâti et culasse. » A1.02 - Carter d'huile et couvercles de bâti. » A1.03 - Vilebrequin et volant moteur. » A1.05 - Bielles et pistons. » A1.06 - Commande de distribution. » A1.07 - Distribution.</p> <p>Groupe A2 Alimentation et échappement</p> <p>Sgr. A2.01 - Réservoir et canalisations carburant. » A2.02 - Pompe et canalisations d'alimentation. » A2.03 - Pompe d'alimentation. » A2.04 - Carburateur et filtre à air. » A2.05 - Filtre à air. » A2.06 - Carburateur. » A2.21 - Commandes d'accélérateur et de starter. » A2.56 - Canalisation d'échappement.</p>	<p>Groupe A3 - Graissage</p> <p>Sgr. A3.01 - Graissage.</p> <p>Groupe A4 - Refroidissement</p> <p>Sgr. A4.07 - Prises d'air et convoyeur. » A4.09 - Ventilateur.</p> <p>B - TRANSMISSION</p> <p>Groupe B1 - Embrayage</p> <p>Sgr. B1.01 - Commande de débrayage. » B1.05 - Embrayage (pièces).</p> <p>Groupe B2 - Boîte de vitesses</p> <p>Sgr. B2.01 - Boîte de vitesses, carter et couvercles. » B2.04 - Pignons de boîte de vitesses. » B2.07 - Commandes extérieures de boîte de vitesses. » B2.10 - Commandes intérieures de boîte de vitesses. » B2.24 - Compteur de vitesse et sa commande.</p> <p>Groupe B4 - Ponts</p> <p>Sgr. B4.01 - Arbres de différentiel. » B4.04 - Engrenages réducteurs et différentiel.</p>	<p>C - FREINS</p> <p>Groupe C1 - Freins aux roues</p> <p>Sgr. C1.01 - Commande au pied de freins. » C1.02 - Commande hydraulique de freins. » C1.06 - Maître-cylindre. » C1.07 - Cylindre de commande mâchoires. » C1.30 - Freins de roues AV. » C1.32 - Freins de roues AR. » C1.35 - Manette de freins.</p> <p>D - DIRECTION, SUSPENSION ET ROUES</p> <p>Groupe D2 - Direction</p> <p>Sgr. D2.01 - Commande de direction. » D2.02 - Boltier de direction. » D2.10 - Tringlerie de direction.</p> <p>Groupe D3 - Suspensions et roues</p> <p>Sgr. D3.01 - Suspension AV. » D3.05 - Suspension AR. » D3.10 - Amortisseurs (D3.10, D3.10/1). » D3.14 - Fusée. » D3.16 - Roues.</p>	<p>E - ORGANES SUBSIDIAIRES</p> <p>Groupe E1 - Chauffage et aération</p> <p>Sgr. E1.01 - Système de chauffage.</p> <p>Groupe E3 - Divers</p> <p>Sgr. E3.01 - Lave-glace.</p> <p>F - INSTALLATION ELECTRIQUE</p> <p>Groupe F1 - Allumage</p> <p>Sgr. F1.01 - Allumage moteur.</p> <p>Groupe F2 - Démarrage</p> <p>Sgr. F2.01 - Lancement du moteur.</p> <p>Groupe F3 - Génératrice</p> <p>Sgr. F3.01 - Génératrice de courant.</p> <p>Groupe F4 - Éclairage</p> <p>Sgr. F4.01 - Éclairage extérieur et intérieur.</p>	<p>Groupe F5 - Accessoires</p> <p>Sgr. F5.01 - Signaux d'appel et de manœuvre. » F5.03 - Témoins de fonctionnement. » F5.05 - Accessoires divers.</p> <p>Groupe F6 - Pièces d'appareils</p> <p>Sgr. F6.02 - Dynamo. » F6.06 - Groupe de réglage. » F6.08 - Démarreur. » F6.14 - Allumeur. » F6.29 - Projecteurs. » F6.32 - Lanternes AV » F6.34 - Lanternes AR. » F6.35 - Feu de plaque. » F6.65 - Essuie-glace.</p> <p>Z - DOTATIONS</p> <p>Groupe Z1 - Outils</p> <p>Sgr. Z1.01 - Outils.</p>
---	---	---	--	--

UNTERGRUPPENVERZEICHNIS

<p style="text-align: center;">A - MOTOR</p> <p style="text-align: center;">Gruppe A0 - Motor</p> <p>Utgr. A0.01 - Motor und Triebwerkklager.</p> <p style="text-align: center;">Gruppe A1 - Hauptorgane</p> <p>Utgr. A1.01 - Kurbelgehäuse und Zylinderkopf.</p> <p>» A1.02 - Oelwanne und Deckel des Kurbelgehäuses.</p> <p>» A1.03 - Kurbelwelle u. Schwungrad.</p> <p>» A1.05 - Pleuelstangen u. Kolben.</p> <p>» A1.06 - Steuerungsantrieb.</p> <p>» A1.07 - Steuerung.</p> <p style="text-align: center;">Gruppe A2 Kraftstoffförderung und Auspuff</p> <p>Utgr. A2.01 - Kraftstofftank und Leitungen.</p> <p>» A2.02 - Kraftstoffpumpe u. Leitungen.</p> <p>» A2.03 - Kraftstoffpumpe.</p> <p>» A2.04 - Vergaser und Luftfilter.</p> <p>» A2.05 - Luftfilter.</p> <p>» A2.06 - Vergaser.</p> <p>» A2.21 - Gasregulierung.</p> <p>» A2.56 - Auspuffleitung.</p>	<p style="text-align: center;">Gruppe A3 - Schmierung</p> <p>Utgr. A3.01 - Schmierung.</p> <p style="text-align: center;">Gruppe A4 - Motorkühlung</p> <p>Utgr. A4.07 - Lufteintritt und Kühlluftführung.</p> <p>» A4.09 - Lüfter.</p> <p style="text-align: center;">B - KRAFTÜBERTRAGUNG</p> <p style="text-align: center;">Gruppe B1 - Kupplung</p> <p>Utgr. B1.01 - Kupplungsbetätigung.</p> <p>» B1.05 - Kupplung (Einzelteile).</p> <p style="text-align: center;">Gruppe B2 - Wechselgetriebe</p> <p>Utgr. B2.01 - Wechsel- und Ausgleichgetriebe, Gehäuse und Deckel.</p> <p>» B2.04 - Zahnräder und Wellen.</p> <p>» B2.07 - Äussere Getriebebeschaltung.</p> <p>» B2.10 - Innere Getriebebeschaltung.</p> <p>» B2.24 - Tachometer und sein Antrieb.</p> <p style="text-align: center;">Gruppe B4 - Hinterachse</p> <p>Utgr. B4.01 - Achswellen.</p> <p>» B4.04 - Achsantrieb und Ausgleichgetriebe.</p>	<p style="text-align: center;">C - BREMSEN</p> <p style="text-align: center;">Gruppe C1 - Radbremsen</p> <p>Utgr. C1.01 - Bremsfusshelbel.</p> <p>» C1.02 - Hydraulische Bremsbetätigung.</p> <p>» C1.06 - Hauptbremszylinder.</p> <p>» C1.07 - Radbremszylinder.</p> <p>» C1.30 - Vorderradbremsen.</p> <p>» C1.32 - Hinterradbremsen.</p> <p>» C1.35 - Handbremsbetätigung.</p> <p style="text-align: center;">D - LENKUNG, AUFHÄNGUNG UND RÄDER</p> <p style="text-align: center;">Gruppe D2 - Lenkung</p> <p>Utgr. D2.01 - Lenkgetriebe.</p> <p>» D2.02 - Lenkgehäuse.</p> <p>» D2.10 - Lenkgestänge.</p> <p style="text-align: center;">Gruppe D3 - Aufhängung und Räder</p> <p>Utgr. D3.01 - Vorderradaufhängung.</p> <p>» D3.05 - Hinterradaufhängung.</p> <p>» D3.10 - Stossdämpfer (D3.10, D3.10/1).</p> <p>» D3.14 - Achsschenkel.</p> <p>» D3.16 - Räder.</p>	<p style="text-align: center;">E - NEBENORGANE</p> <p style="text-align: center;">Gruppe E1 - Heizung und Belüftung</p> <p>Utgr. E1.01 - Luftheizungsanlage.</p> <p style="text-align: center;">Gruppe E3 - Verschiedenes</p> <p>Utgr. E3.01 - Scheibenwascher.</p> <p style="text-align: center;">F - ELEKTRISCHE ANLAGE</p> <p style="text-align: center;">Gruppe F1 - Zündanlage</p> <p>Utgr. F1.01 - Motorzündung.</p> <p style="text-align: center;">Gruppe F2 - Anlassen</p> <p>Utgr. F2.01 - Anlassen des Motors.</p> <p style="text-align: center;">Gruppe F3 - Stromanlage</p> <p>Utgr. F3.01 - Stromerzeugung.</p> <p style="text-align: center;">Gruppe F4 - Beleuchtung</p> <p>Utgr. F4.01 - Aussen- und Innenbeleuchtung.</p>	<p style="text-align: center;">Gruppe F5 - Zubehör</p> <p>Utgr. F5.01 - Signalisiervorrichtungen.</p> <p>» F5.03 - Anzeigevorrichtungen.</p> <p>» F5.05 - Verschiedenes Zubehör.</p> <p style="text-align: center;">Gruppe F6 - Einzelteile der Geräte</p> <p>Utgr. F6.02 - Lichtmaschine.</p> <p>» F6.06 - Reglergruppe.</p> <p>» F6.08 - Anlasser.</p> <p>» F6.14 - Zündverteiler.</p> <p>» F6.29 - Scheinwerfer.</p> <p>» F6.32 - Vordere Leuchten.</p> <p>» F6.34 - Hintere Leuchten.</p> <p>» F6.35 - Nummernschildleuchte.</p> <p>» F6.65 - Scheibenwischer.</p> <p style="text-align: center;">Z - WERKZEUGE</p> <p style="text-align: center;">Gruppe Z1 - Werkzeuge</p> <p>Utgr. Z1.01 - Werkzeuge.</p>
--	---	--	--	---

SUBGROUP INDEX

<p>A - ENGINE</p> <p>Group A0 - Engine Assembly</p> <p>Sgr. A0.01 - Engine and Power Plant Supports.</p> <p>Group A1 - Main Components</p> <p>Sgr. A1.01 - Crankcase and Cylinder Head.</p> <p>» A1.02 - Oil Sump and Crankcase Covers.</p> <p>» A1.03 - Crankshaft and Flywheel.</p> <p>» A1.05 - Connecting Rods and Pistons.</p> <p>» A1.06 - Camshaft Drive.</p> <p>» A1.07 - Valve Gear.</p> <p>Group A2 - Fuel and Exhaust Systems</p> <p>Sgr. A2.01 - Fuel Tank and Lines.</p> <p>» A2.02 - Fuel Pump and Lines.</p> <p>» A2.03 - Fuel Pump.</p> <p>» A2.04 - Carburetor and Air Cleaner.</p> <p>» A2.05 - Air Cleaner.</p> <p>» A2.06 - Carburetor.</p> <p>» A2.21 - Choke and Accelerator Control Linkage.</p> <p>» A2.56 - Exhaust Pipe.</p>	<p>Group A3 - Lubrication System</p> <p>Sgr. A3.01 - Lubrication System.</p> <p>Group A4 - Cooling System</p> <p>Sgr. A4.07 - Air Intakes and Conveyor.</p> <p>» A4.09 - Fan.</p> <p>B - POWER TRAIN</p> <p>Group B1 - Clutch</p> <p>Sgr. B1.01 - Clutch Release Control.</p> <p>» B1.05 - Clutch (components).</p> <p>Group B2 - Transmission</p> <p>Sgr. B2.01 - Transmission - and - Differential Unit, Casing and Covers.</p> <p>» B2.04 - Transmission Gears.</p> <p>» B2.07 - Gearshift Outer Controls.</p> <p>» B2.10 - Gearshift Inner Controls.</p> <p>» B2.24 - Speedometer and Drive.</p> <p>Group B4 - Axles</p> <p>Sgr. B4.01 - Axle and axle Shafts.</p> <p>» B4.04 - Final Drive and Differential Gears.</p>	<p>C - BRAKES</p> <p>Group C1 - Service Brakes</p> <p>Sgr. C1.01 - Brake Foot Control.</p> <p>» C1.02 - Brake Hydraulic System.</p> <p>» C1.06 - Master Cylinder.</p> <p>» C1.07 - Wheel Cylinder.</p> <p>» C1.30 - Front Wheel Brakes.</p> <p>» C1.32 - Rear Wheel Brakes.</p> <p>» C1.35 - Brake Hand Control.</p> <p>D - STEERING, SUSPENSION AND WHEELS</p> <p>Group D2 - Steering System</p> <p>Sgr. D2.01 - Steering Gear.</p> <p>» D2.02 - Steering Box.</p> <p>» D2.10 - Steering Linkage.</p> <p>Group D3 - Suspensions and Wheels</p> <p>Sgr. D3.01 - Front Suspension.</p> <p>» D3.05 - Rear Suspension.</p> <p>» D3.10 - Shock Absorbers (D3.10, D3.10 1).</p> <p>» D3.14 - Steering Knuckle.</p> <p>» D3.16 - Wheels.</p>	<p>E - ACCESSORY EQUIPMENT</p> <p>Group E1 - Ventilation and Heating</p> <p>Sgr. E1.01 - Heating Equipment.</p> <p>Group E3 - Miscellanea</p> <p>Sgr. E3.01 - Windshield Washer.</p> <p>F - ELECTRICAL SYSTEM</p> <p>Group F1 - Ignition Equipment</p> <p>Sgr. F1.01 - Engine Ignition System.</p> <p>Group F2 - Starting Equipment</p> <p>Sgr. F2.01 - Engine Starting Equipment.</p> <p>Group F3 - Generating Equipment</p> <p>Sgr. F3.01 - Current Generating System.</p> <p>Group F4 - Lighting Equipment</p> <p>Sgr. F4.01 - Outer and Inner Lighting.</p>	<p>Group F5 - Accessories</p> <p>Sgr. F5.01 - Signalling Devices.</p> <p>» F5.03 - Operation Indicators.</p> <p>» F5.05 - Miscellaneous Accessories.</p> <p>Group F6 - Component Parts</p> <p>Sgr. F6.02 - Generator.</p> <p>» F6.06 - Regulating Unit.</p> <p>» F6.08 - Starter Motor.</p> <p>» F6.14 - Ignition Distributor.</p> <p>» F6.29 - Headlamps.</p> <p>» F6.32 - Front Lamps.</p> <p>» F6.34 - Tail Lamps.</p> <p>» F6.35 - Number Plate Lamp.</p> <p>» F6.65 - Windshield Wiper.</p> <p>Z - TOOL EQUIPMENT</p> <p>Group Z1 - Tools</p> <p>Sgr. Z1.01 - Tools.</p>
---	---	--	---	--

ÍNDICE DE SUBGRUPOS

<p style="text-align: center;">A - MOTOR</p> <p>Grupo A0 - Conjunto del motor</p> <p>Sgr. A0.01 - Motor y anclaje de la planta motriz.</p> <p>Grupo A1 - Órganos principales</p> <p>Sgr. A1.01 - Bloque de cilindros y culata.</p> <p>» A1.02 - Cáster de aceite y tapas del bloque.</p> <p>» A1.03 - Cigüeñal y volante.</p> <p>» A1.05 - Bielas y émbolos.</p> <p>» A1.06 - Piñones de la distribución.</p> <p>» A1.07 - Distribución.</p> <p>Grupo A2 - Alimentación y escape</p> <p>Sgr. A2.01 - Depósito de combustible y tuberías.</p> <p>» A2.02 - Bomba de alimentación y tuberías.</p> <p>» A2.03 - Bomba de alimentación.</p> <p>» A2.04 - Carburador y filtro de aire.</p> <p>» A2.05 - Filtro de aire.</p> <p>» A2.06 - Carburador.</p> <p>» A2.21 - Mandos del acelerador y « stárter ».</p> <p>» A2.56 - Tubería de escape.</p>	<p style="text-align: center;">Grupo A3 - Engrase</p> <p>Sgr. A3.01 - Sistema de engrase.</p> <p style="text-align: center;">Grupo A4 - Refrigeración</p> <p>Sgr. A4.07 - Bocas de aire y canalizador.</p> <p>» A4.09 - Ventilador.</p> <p style="text-align: center;">B - TRANSMISIÓN</p> <p style="text-align: center;">Grupo B1 - Embrague</p> <p>Sgr. B1.01 - Sistema de embrague.</p> <p>» B1.05 - Embrague (despiezo).</p> <p style="text-align: center;">Grupo B2 - Cambio de velocidades</p> <p>Sgr. B2.01 - Cambio y diferencial, caja y tapas.</p> <p>» B2.04 - Engranajes del cambio.</p> <p>» B2.07 - Varillaje del cambio de velocidades.</p> <p>» B2.10 - Barras del cambio de velocidades.</p> <p>» B2.24 - Velocímetro y su arrastre.</p> <p style="text-align: center;">Grupo B4 - Puente</p> <p>Sgr. B4.01 - Palieres.</p> <p>» B4.04 - Reducción final y diferencial.</p>	<p style="text-align: center;">C - FRENOS</p> <p style="text-align: center;">Grupo C1 - Frenos de ruedas</p> <p>Sgr. C1.01 - Pedal de freno.</p> <p>» C1.02 - Sistema de freno hidráulico.</p> <p>» C1.06 - Bomba.</p> <p>» C1.07 - Cilindro de freno.</p> <p>» C1.30 - Frenos anteriores.</p> <p>» C1.32 - Frenos posteriores.</p> <p>» C1.35 - Freno de mano.</p> <p style="text-align: center;">D - DIRECCIÓN, SUSPENSIÓN Y RUEDAS</p> <p style="text-align: center;">Grupo D2 - Dirección</p> <p>Sgr. D2.01 - Volante y caja de la dirección.</p> <p>» D2.02 - Caja de la dirección.</p> <p>» D2.10 - Timonería de la dirección.</p> <p style="text-align: center;">Grupo D3 - Suspensión y ruedas</p> <p>Sgr. D3.01 - Suspensión anterior.</p> <p>» D3.05 - Suspensión posterior.</p> <p>» D3.10 - Amortiguadores (D3.10, D3.10/1).</p> <p>» D3.14 - Mangueta.</p> <p>» D3.16 - Ruedas.</p>	<p style="text-align: center;">E - EQUIPOS ACCESORIOS</p> <p style="text-align: center;">Grupo E1</p> <p style="text-align: center;">Sistema de calefacción y ventilación</p> <p>Sgr. E1.01 - Sistema de calefacción.</p> <p style="text-align: center;">Grupo E3 - Accesorios varios</p> <p>Sgr. E3.01 - Lava-parabrisas.</p> <p style="text-align: center;">F - INSTALACIÓN ELÉCTRICA</p> <p style="text-align: center;">Grupo F1 - Encendido</p> <p>Sgr. F1.01 - Encendido del motor.</p> <p style="text-align: center;">Grupo F2 - Arranque del motor</p> <p>Sgr. F2.01 - Arranque del motor.</p> <p style="text-align: center;">Grupo F3 - Generador</p> <p>Sgr. F3.01 - Generador de corriente.</p> <p style="text-align: center;">Grupo F4 - Alumbrado</p> <p>Sgr. F4.01 - Alumbrado exterior e interior.</p>	<p style="text-align: center;">Grupo F5 - Accesorios</p> <p>Sgr. F5.01 - Aparatos de señalización.</p> <p>» F5.03 - Testigos de funcionamiento.</p> <p>» F5.05 - Accesorios varios.</p> <p style="text-align: center;">Grupo F6 - Despiezo de aparatos</p> <p>Sgr. F6.02 - Dinamo.</p> <p>» F6.06 - Regulador-disyuntor.</p> <p>» F6.08 - Motor de arranque.</p> <p>» F6.14 - Distribuidor de encendido.</p> <p>» F6.29 - Proyectores.</p> <p>» F6.32 - Lámparas anteriores.</p> <p>» F6.34 - Lámparas posteriores.</p> <p>» F6.35 - Lámpara de matrícula.</p> <p>» F6.65 - Limpia-parabrisas.</p> <p style="text-align: center;">Z - EQUIPO</p> <p style="text-align: center;">Grupo Z1 - Herramientas</p> <p>Sgr. Z1.01 - Herramientas.</p>
--	--	--	--	--

INDICE DEI NUMERI D'ORDINAZIONE

Liste numérique — Nummernverzeichnis — Numerical Index — Índice numérico

Bianchina Panoramica e derivati

n. ordinaz.	Sgr.	n. ordinaz.	Sgr.	n. ordinaz.	Sgr.	n. ordinaz.	Sgr.	n. ordinaz.	Sgr.
202224	D2.02	816159	C1.01/1	876015	A2.01	890418	D3.01	969870	B2.04
336501	D2.02	816169	C1.01	877277	A3.01	891605	B4.04	969876	B2.04
311300	F6.02	816446	E1.01	877277	A3.01/1	891631	B2.10	970281	B4.04
336514	D2.02	818371	F6.08	878770	C1.07	891633	B2.10	970282	B4.04
336658	D3.14	832632	D3.05	879733	C1.32	894037	D3.05	970283	B4.04
336659	D3.14	838589	C1.02	879886	A2.01	894040	D3.05	970284	B4.04
355301	B2.10	841590	C1.02	879886	C1.02	894336	C1.35	970290	B4.01
372587	F5.01	841590	C1.02/1	879886	C1.02/1	898516	F4.01/2	970679	B2.01
637410	F6.08	849128	D3.05	879886	F3.01	899497	D3.14	970801	B2.10
672541	F6.08	857808	C1.35	880393	D2.02	899498	D3.14	970803	B2.10
672568	F6.08	857810	C1.35	880394	D2.02	899499	D3.14	970810	B2.10
672948	F6.08	858394	D2.10	880484	D2.02	899500	D3.14	970812	B2.01
672949	F6.08	860067	C1.06	880673	A2.21	899501	D3.14	970813	B2.01
672950	F6.08	861290	D3.01	881667	A1.02	900341	A1.06	970814	B2.01
673196	F6.08	861723	F3.01	882479	D3.16	900701	A1.01	970815	B2.01
704846	D2.02	867900	F6.08	883050	E1.01	900812	A2.06	971291	B1.01
722763	Z1.01	869763	D3.14	883175	B2.01	900821	A2.06	972020	B2.04
725662	F3.01	869765	D3.14	883323	F6.02	900829	A2.06	972486	C1.35
734699	B2.04	870736	B2.07	883323	F6.02/1	901083	D3.01	972495	C1.35
734700	B2.04	870737	B2.07	885119	A2.21	901084	D3.05	973910	B1.05
739431	D3.01	870738	B2.07	887752	F2.01	901085	D3.14	974592	E1.01
740484	C1.02	873475	C1.06	887914	F6.06	902017	A1.05	975061	D3.14
743601	D2.01	873637	D3.14	887915	F6.06	902018	A1.05	975664	B2.04
804862	B4.01	874488	F4.01	888019	B2.24	902019	A1.05	977235	B1.01
805581	F6.08	874488	F4.01/1	888738	F4.01/2	902020	A1.05	977352	A2.21
805599	F6.08	874488	F4.01/2	889633	A1.05	902021	A1.05	979314	B2.07
809064	C1.02	874488	F4.01/3	889956	C1.02	902022	A1.05	980593	B1.01
809064	C1.02/1	874488	F5.03	889956	C1.02/1	902065	A1.05	980598	C1.01
809065	C1.02	874488	F5.03/1	889957	C1.02	902066	A1.05	980598	C1.01/1
809065	C1.02/1	874488	F5.05	889957	C1.02/1	902067	A1.05	980848	C1.06
811134	B2.24	874690	B2.01	890292	B4.01	902068	A1.05	983028	B2.10
811731	A2.21	875118	C1.35	890400	D3.01	965201	D2.01	983404	A2.21
813729	A2.21	875554	B2.07	890413	D3.01	965713	A1.03	984069	B2.24
814635	D3.16	875605	D3.05	890414	D3.01	965849	F3.01	984070	B2.24
814838	A2.21	875666	B2.24	890415	D3.01	967540	B2.04	985783	D3.14

Bianchina Panoramica e derivati

n. ordinaz.	Sgr.	n. ordinaz.	Sgr.	n. ordinaz.	Sgr.	n. ordinaz.	Sgr.	n. ordinaz.	Sgr.
986086	D3.01	987057	A3.01/1	991079	D2.10	1107295	F4.01/1	1111179	F4.01/3
986090	D3.01	987064	A1.07	991293	D2.10	1107434	F4.01	1111180	F4.01
986091	D3.01	987099	A3.01	992273	A2.01	1107434	F4.01/1	1111180	F4.01/1
986093	D3.01	987099	A3.01/1	992602	E1.01	1107434	F4.01/3	1111180	F4.01/3
986141	C1.01	987109	A3.01	992603	E1.01	1109190	F5.05	1111271	F5.01
986141	C1.01/1	987109	A3.01/1	992767	B2.07	1109556	E1.01	1111272	F5.01
986143	C1.01	987112	A3.01	992768	B2.07	1110445	F5.01	1113132	F5.01
986143	C1.01/1	987112	A3.01/1	994922	C1.02	1110837	D3.16	1113133	F5.01
986144	C1.01	987357	D3.01	994922	C1.02/1	1111069	F4.01	1113602	F4.01/1
986144	C1.01/1	987358	D3.01	996623	A2.02	1111070	F4.01	1113604	F4.01/1
986145	B1.01	987376	B1.01	997807	B2.01	1111072	F4.01	1114061	F4.01/3
986145	C1.01	987379	C1.01	997807	F2.01	1111072	F4.01/3	1114064	F5.03
986145	C1.01/1	987379	C1.01/1	999858	F4.01	1111112	Z1.01	1114068	F5.03
986147	C1.01/1	987476	C1.01/1	999858	F4.01/3	1111161	F4.01	1114151	F4.01/3
986308	D2.02	987773	C1.06	1102904	F4.01	1111161	F4.01/3	1114794	D3.05
986309	D2.02	987788	D3.01	1102904	F4.01/1	1111167	F4.01	1114832	E1.01
986328	C1.30	987789	D3.01	1104621	F4.01	1111167	F4.01/1	1114833	E1.01
986328	C1.32	987791	D3.01	1104621	F4.01/1	1111167	F4.01/3	1114866	F4.01/1
986677	A0.01	987819	F6.02	1104621	F4.01/3	1111168	F4.01	1114883	E3.01
986678	A0.01	987820	F6.02	1104624	F4.01	1111168	F4.01/1	1114884	E3.01
986842	B4.01	988072	D2.10	1105463	F5.03	1111168	F4.01/3	1115519	F5.03/1
986951	A1.01	988447	A3.01/1	1105471	F5.03	1111175	F4.01	1115520	F5.03/1
986952	A1.01	988705	C1.02	1105475	F5.03	1111175	F4.01/1	1115525	F5.01
986963	A1.03	988706	C1.02	1105477	F5.03	1111175	F4.01/3	1115706	F5.01
986964	A1.03	989611	F6.02	1105478	F5.03	1111176	F4.01	1115964	F4.01/1
987006	A1.05	989611	F6.02/1	1105982	F5.05	1111176	F4.01/1	1115969	F4.01/1
987008	A1.05	989617	F6.02	1106569	E3.01/1	1111176	F4.01/3	1115972	F4.01/1
987009	A1.05	989617	F6.02/1	1106799	D2.01	1111177	F4.01	1115972	F4.01/3
987044	A1.06	989625	F6.02	1106864	F4.01	1111177	F4.01/1	1115973	F4.01/1
987048	A1.06	990055	F4.01	1106864	F4.01/1	1111177	F4.01/3	1115973	F4.01/3
987056	A1.07	990055	F4.01/1	1106864	F4.01/3	1111178	F4.01	4002507	A1.01
987056	A3.01	990055	F4.01/3	1107250	F4.01	1111178	F4.01/1	4003331	E3.01/1
987056	A3.01/1	990114	B2.24	1107250	F4.01/1	1111178	F4.01/3	4003331	E3.01/2
987057	A1.07	990530	E1.01	1107250	F4.01/3	1111179	F4.01	4003334	E3.01/1
987057	A3.01	990986	D2.10	1107295	F4.01	1111179	F4.01/1	4004123	A1.07

Bianchina Panoramica e derivati

n. ordinaz.	Sgr.	n. ordinaz.	Sgr.	n. ordinaz.	Sgr.	n. ordinaz.	Sgr.	n. ordinaz.	Sgr.
4004249	E3.01/1	4033658	D2.01	4047142	A3.01/1	4053012	D2.02	4056207	F6.02
4007819	F3.01	4033767	F6.02	4047145	A3.01	4053152	A3.01	4056210	F6.02
4007946	C1.07	4033770	F6.02	4047145	A3.01/1	4053152	A3.01/1	4056317	F6.14
4008919	C1.35	4033770	F6.02/1	4047577	F6.14	4054367	A1.02	4056317	F6.14/1
4008927	C1.30	4034044	A1.03	4047577	F6.14/1	4054401	A4.07	4056391	A0.01
4008927	C1.32	4034045	A1.05	4047734	A2.02	4054402	A4.07	4056392	A0.01
4008928	C1.30	4034364	F6.02	4048205	E1.01	4054483	A3.01	4056400	A1.03
4008928	C1.32	4035670	F1.01	4048307	D3.01	4054483	A3.01/1	4056401	A1.03
4009308	D2.02	4037747	A1.05	4048471	F6.08	4054528	F6.14	4056402	A1.03
4009925	F3.01	4037750	A1.05	4048780	E1.01	4054528	F6.14/1	4056403	A1.03
4010948	F5.03	4037757	A1.07	4049529	A0.01	4054594	A3.01	4056404	A1.03
4012477	B2.01	4037820	B4.01	4049533	A0.01	4054594	A3.01/1	4056419	A1.03
4013788	B2.04	4037843	F6.02	4049690	A1.03	4054763	A2.02	4056644	F4.01/2
4014771	B2.01	4037844	F6.02	4049790	A1.01	4054850	C1.30	4056676	A2.04
4015443	A1.07	4038256	A1.07	4049791	A1.01	4054850	C1.32	4056844	F3.01
4016311	B2.01	4038375	A1'06	4049811	A1.06	4054913	A3.01	4057029	C1.02
4017013	A3.01	4038840	F4.01	4049812	A1.06	4054913	A3.01/1	4057030	C1.02
4017013	A3.01/1	4038840	F4.01/3	4049953	A1.02	4054931	A3.01	4057031	C1.02
4017057	F6.02	4042300	A4.09	4050429	A2.21	4054931	A3.01/1	4057032	C1.02
4017057	F6.02/1	4042658	F4.01	4050430	A2.21	4055161	A4.07	4057053	C1.02
4019754	B2.07	4042658	F4.01/1	4050536	B2.01	4055241	A0.01	4057054	C1.02
4019755	B2.07	4042658	F4.01/2	4050539	F5.03/1	4055242	A0.01	4057315	A1.02
4019994	B2.24	4042923	D2.02	4050554	B2.07	4055243	A0.01	4057404	A2.56
4019997	B2.24	4044325	F4.01	4050556	C1.02	4055244	A0.01	4057420	A2.56
4020029	B2.04	4044325	F4.01/1	4050559	F3.01	4055245	A0.01	4057421	A2.56
4020031	B2.10	4044325	F4.01/2	4050761	A4.07	4055495	A1.06	4057571	C1.02
4022865	F1.01	4044325	F4.01/3	4050762	A4.07	4055561	A2.04	4057602	A4.07
4024191	D3.01	4044416	D3.05	4051369	D2.02	4055562	A2.04	4057612	A2.04
4025729	F4.01	4044421	C1.32	4051449	A1.06	4055563	A2.04	4057904	F6.02
4027581	B2.07	4045504	B2.04	4051454	A1.07	4055564	A2.21	4058051	F4.01/2
4029072	B2.24	4046512	C1.30	4052231	E1.01	4055632	A4.09	4058407	A2.56
4029189	C1.02	4046512	C1.32	4052655	A4.07	4055693	A2.04	4058540	F6.06
4029189	C1.02/1	4046516	C1.35	4052891	F5.05	4055694	A2.04	4058773	F6.06
4029190	C1.02	4047061	A1.01	4052892	F5.05	4055745	A2.05	4058833	Z1.01
4032965	B2.04	4047071	A2.56	4052946	F5.05	4056203	F3.01	4058836	C1.02

Bianchina Panoramica e derivati

n. ordinaz.	Sgr.	n. ordinaz.	Sgr.	n. ordinaz.	Sgr.	n. ordinaz.	Sgr.	n. ordinaz.	Sgr.
4058859	A1.07	4061964	F3.01	4065615	F6.02/1	4074630	A3.01/1	4091352	D2.02
4058951	A1.07	4061965	F3.01	4065727	F6.08	4075300	A1.05	4091440	F6.02
4059005	D3.05	4062201	B2.04	4065728	F6.08	4075301	A1.05	4091440	F6.02/1
4059006	D3.05	4062326	A2.21	4065798	C1.30	4075394	F6.02/1	4091697	Z1.01
4059029	D3.01	4062519	A2.04	4065799	C1.30	4075599	A0.01	4092508	A2.21
4059193	F6.02	4062765	F6.06	4066276	F4.01/3	4077589	C1.02/1	4092513	F1.01
4059201	A4.07	4063030	A1.05	4066512	F5.01	4078211	A3.01	4092521	C1.32
4059202	A4.07	4063031	A1.05	4067417	C1.35	4078211	A3.01/1	4092687	A1.03
4059320	F4.01	4063032	A1.05	4067418	C1.35	4078568	C1.02/1	4092689	A1.03
4059320	F4.01/1	4063034	A1.05	4067439	C1.32	4078610	A3.01	4094933	B4.01
4059320	F4.01/2	4063035	A1.05	4067440	C1.32	4078610	A3.01/1	4094974	A2.02
4059320	F4.01/3	4063036	A1.05	4067806	A3.01/1	4078611	A3.01	4096718	F1.01
4060456	A1.02	4063679	F6.08	4067814	F4.01	4078611	A3.01/1	4099013	F4.01/2
4060457	A1.02	4063734	A3.01	4067814	F4.01/1	4080533	D3.16	4099978	C1.02
4060475	A4.07	4063734	A3.01/1	4067814	F4.01/2	4081257	A2.02	4099978	C1.02/1
4060513	F3.01	4063852	A1.01	4067814	F4.01/3	4081258	A2.02	4100548	C1.02
4060514	F3.01	4064003	F1.01	4068849	A4.09	4082332	D2.10	4100548	C1.02/1
4060515	F3.01	4064439	B2.04	4068954	A1.07	4082585	A2.02	4100867	D2.10
4060516	A4.09	4064453	D3.05	4069103	F5.01	4082645	A2.04	4100871	D2.10
4060517	A4.09	4064454	D3.05	4069375	C1.35	4082646	A2.04	4100948	F5.03/1
4060518	A4.09	4064490	A1.07	4069392	E3.01	4082647	A2.04	4100998	D2.10
4060532	A4.09	4064493	A1.07	4069396	C1.35	4083137	F1.01	4101148	B2.24
4060537	A4.07	4064494	A1.07	4070061	E3.01	4084443	C1.30	4101150	B2.24
4060538	A4.07	4064495	A3.01	4070210	A4.07	4084545	F3.01	4101670	D3.05
4061033	B1.01	4064495	A3.01/1	4071156	F4.01	4084610	B2.04	4101807	D2.10
4061411	F6.08	4064496	D3.05	4071156	F4.01/3	4085089	B2.04	4101808	D2.10
4061419	E1.01	4065042	A1.05	4071170	C1.02	4085554	A2.21	4101815	D2.10
4061420	E1.01	4065093	A2.05	4071170	C1.02/1	4085554	F2.01	4102377	D2.10
4061421	E1.01	4065322	A2.04	4071394	F1.01	4086812	B2.24	4102378	D2.10
4061429	E1.01	4065452	F6.34/1	4071584	B2.04	4087165	B2.04	4102793	F4.01/1
4061432	E1.01	4065453	F6.34/1	4071585	B2.04	4087766	A2.21	4102850	D3.14
4061935	F3.01	4065480	F6.02	4072152	A0.01	4090637	A2.02	4102851	D3.14
4061936	F3.01	4065480	F6.02/1	4072798	A3.01	4091349	D2.02	4103528	C1.01
4061950	F3.01	4065593	F1.01	4072798	A3.01/1	4091350	D2.02	4104000	C1.35
4061963	F3.01	4065615	F6.02	4073295	B2.04	4091351	D2.02	4104085	D2.10

Bianchina Panoramica e derivati

n. ordinaz.	Sgr.	n. ordinaz.	Sgr.	n. ordinaz.	Sgr.	n. ordinaz.	Sgr.	n. ordinaz.	Sgr.
4104577	C1.32	4108018	B4.01	4111171	B4.01	4117843	B2.01	4121620	C1.07
4104579	D2.02	4108019	B4.01	4111201	B1.05	4117900	A1.07	4121625	D3.05
4104877	C1.35	4108021	B4.01	4111374	F6.02	4118017	B4.01	4121796	C1.30
4104879	C1.35	4108023	B4.01	4111915	B2.01	4118109	B1.01	4121796	C1.32
4104921	C1.02/1	4108051	B4.04	4111916	F2.01	4118150	A1.01	4122230	B2.07
4104937	C1.35	4108052	B4.04	4111917	B2.07	4118224	A0.01	4122374	F4.01/2
4104964	C1.35	4108053	B4.04	4112045	A1.05	4118225	A1.03	4122408	B2.04
4104966	D3.01	4108054	B4.04	4112046	A1.05	4118227	A4.07	4122568	A2.21
4104966	D3.01	4108055	B4.04	4113070	B4.01	4118228	A4.07	4122648	A2.01
4104967	D3.01	4108056	B4.04	4113070	D3.14	4118229	A4.07	4122750	D3.16
4104968	D3.01	4108057	B4.04	4114059	A3.01	4119397	C1.35	4122806	B2.24
4104970	D3.01	4108072	B1.01	4114235	E3.01/1	4119398	C1.35	4122807	C1.02
4104971	D3.01	4108077	B1.01	4115451	C1.06	4119399	C1.35	4122807	C1.02/1
4104972	D3.01	4108294	A3.01/1	4115451	C1.07	4119629	B1.01	4122826	C1.02
4104973	D3.01	4108561	B4.01	4115603	D3.05	4119727	B2.01	4122826	C1.02/1
4104975	D3.01	4108753	A1.02	4115661	F4.01/3	4119730	F4.01	4122850	B2.24
4104976	D3.01	4108755	A1.03	4115760	A1.02	4119858	F6.02	4122851	B2.24
4104977	D3.01	4108756	A1.03	4115762	A3.01	4119858	F6.02/1	4123173	D3.14
4104978	D3.01	4108757	A1.03	4115762	A3.01/1	4120373	F5.03	4123174	D3.14
4104979	D3.01	4108758	A1.03	4115765	A4.07	4120373	F5.03/1	4123175	D3.14
4104982	D3.01	4108759	A1.03	4115818	F3.01	4120456	B4.01	4123176	D3.14
4105856	B1.01	4108760	A1.03	4116073	C1.32	4120481	D3.05	4123177	D3.14
4106420	F4.01/3	4108767	A3.01	4116161	B1.05	4120482	D3.05	4123178	D3.14
4107366	D2.01	4108767	A3.01/1	4116164	B1.05	4120484	A1.03	4123179	D3.14
4107995	B2.04	4109335	F6.08	4116291	B4.01	4120502	F6.02	4123180	D3.14
4107997	B2.10	4110099	D2.02	4116292	B4.01	4120502	F6.02/1	4123181	D3.14
4107998	B2.10	4110404	D2.01	4116522	B2.07	4120548	F6.08	4123182	D3.14
4107999	B2.10	4110405	D2.02	4116657	D3.05	4120550	F6.08	4123183	D3.14
4108002	B4.04	4110543	D2.02	4116792	F4.01/3	4120686	B2.10	4123184	D3.14
4108003	B4.04	4110571	D3.01	4116800	F6.34/1	4120875	F6.08	4123185	D3.14
4108004	B4.04	4110615	C1.02	4116962	A1.05	4121144	A2.01	4123838	F4.01/1
4108005	B4.04	4110615	C1.02/1	4116963	A1.05	4121172	A2.02	4124025	A1.01
4108008	B4.04	4110971	D2.01	4117464	F2.01	4121367	B4.01	4124027	C1.06
4108009	B4.04	4111030	D2.02	4117468	F6.08	4121616	C1.02	4124060	A2.21
4108013	B4.04	4111168	B4.01	4117537	F2.01	4121616	C1.02/1	4124419	E1.01

Bianchina Panoramica e derivati

n. ordinaz.	Sgr.	n. ordinaz.	Sgr.	n. ordinaz.	Sgr.	n. ordinaz.	Sgr.	n. ordinaz.	Sgr.
4124504	C1.30	4127415	Z1.01	4136931	F4.01/2	4144916	A2.02	4160924	D2.01
4125404	C1.32	4128555	B2.04	4137061	F4.01/2	4145448	F6.02	4161986	A1.07
4124516	E3.01	4128556	B2.04	4137062	F4.01/2	4145448	F6.02/1	4161987	A1.07
4124516	E3.01/1	4128557	B2.04	4137063	F4.01/2	4146046	F3.01	4161988	A1.07
4124516	E3.01/2	4129430	E3.01	4137064	F4.01/2	4146047	F6.02	4162065	B2.01
4124546	A1.01	4129904	F5.03/1	4137179	B4.01	4146047	F6.02/1	4162944	C1.35
4124786	F4.01/2	4129905	F5.03/1	4137702	A2.21	4146094	A2.01	4164655	F4.01/1
4124792	A1.05	4130315	A2.01	4137703	B2.01	4147121	A1.05	4165210	F5.03
4124793	A1.05	4130321	A2.01	4137985	A1.07	4147122	A1.05	4165210	F5.03/1
4124794	A1.05	4130330	A2.01	4138737	B4.04	4149623	A1.05	4167810	C1.02/1
4124796	A1.05	4130331	A2.01	4141676	F5.01	4149677	A1.02	4167812	C1.02/1
4124797	A1.05	4130332	A2.01	4141678	F5.03	4149678	A3.01	4167816	C1.02/1
4124798	A1.05	4130335	A2.01	4141678	F5.03/1	4149683	A4.07	4167818	C1.02/1
4124929	F2.01	4130367	B1.01	4141679	F5.03	4149757	A0.01	4167820	C1.02/1
4124934	F3.01	4130367	C1.01	4141679	F5.03/1	4149758	A1.02	4167822	C1.02/1
4124936	A3.01	4130367	C1.01/1	4141757	C1.01	4149759	A1.02	4167825	C1.02/1
4125052	E3.01	4130579	A2.01	4142061	A2.01	4149791	A2.04	4167827	C1.02/1
4125052	E3.01/2	4130580	A2.01	4143136	F4.01/3	4149959	A0.01	4167828	C1.02/1
4125053	E3.01	4132149	A2.21	4143378	A1.07	4150570	A1.01	4167830	C1.02/1
4125053	E3.01/2	4132198	A2.01	4143727	A2.02	4151243	A3.01	4167832	C1.02/1
4125327	B1.01	4132747	F6.02	4143946	F6.02/1	4151243	A3.01/1	4167919	A2.02
4125331	B1.01	4132747	F6.02/1	4144244	F6.02/1	4151245	A3.01	4168030	C1.02/1
4125332	B1.01	4135279	F5.01	4144370	B1.01	4151245	A3.01/1	4168032	C1.02/1
4125893	F6.32/1	4135574	E3.01/2	4144373	B1.01	4152224	A3.01	4169420	B2.07
4125894	F6.32/1	4135575	E3.01/2	4144374	C1.01	4156004	F4.01/1	4169421	B2.07
4125899	F6.32/1	4135924	D2.01	4144375	C1.01	4156004	F4.01/3	4169720	B2.10
4126068	F4.01/2	4135925	F5.01	4144378	B1.01	4156014	A3.01	4170839	B2.24
4126364	A2.21	4136135	F6.02/1	4144379	C1.01	4156930	A4.09	4170840	B2.24
4127012	B1.01	4136136	B2.01	4144381	C1.01	4157182	A2.21	4170842	B2.24
4127015	A1.01	4136540	A0.01	4144384	C1.01	4157329	A2.21	4171013	B2.24
4127040	B1.01	4136923	F4.01/2	4144385	C1.01	4158167	F4.01/1	4171388	F4.01/1
4127043	B1.01	4136924	F4.01/2	4144388	C1.01	4158929	B1.01	4171388	F4.01/2
4127076	B1.05	4136925	F4.01/2	4144433	C1.01	4159058	A1.01	4171388	F4.01/3
4127078	B1.01	4136927	F4.01/2	4144699	F6.02/1	4159060	A1.01	4174484	A1.07
4127153	A2.21	4136929	F4.01/2	4144730	A2.02	4159152	F5.03/1	4174485	A1.07

Bianchina Panoramica e derivati

n. ordinaz.	Sgr.	n. ordinaz.	Sgr.	n. ordinaz.	Sgr.	n. ordinaz.	Sgr.	n. ordinaz.	Sgr.
4174725	C1.02/1	9903307	F6.14/1	9905731	D3.10/1	9908081	D3.10	9908408	F6.32
4176016	F4.01/2	9903315	F6.14	9905732	D3.10	9908081	D3.10/1	9908410	F6.35
4178038	B1.01	9903315	F6.14/1	9905732	D3.10/1	9908083	D3.10	9908429	F6.14
4180561	C1.02/1	9903321	F6.14	9905735	D3.10	9908083	D3.10/1	9908429	F6.14/1
4180719	F5.03	9903321	F6.14/1	9905735	D3.10/1	9908084	D3.10	9908434	F6.65
4180721	F4.01/2	9903328	F6.14	9905736	D3.10	9908084	D3.10/1	9908435	F6.65
4180722	F4.01/1	9903328	F6.14/1	9905736	D3.10/1	9908085	D3.10	9908493	A2.06
4180722	F4.01/3	9904680	A2.06	9906838	A2.06	9908085	D3.10/1	9908554	A2.06
4180726	F5.05	9904703	A2.06	9906842	D3.10	9908086	D3.10	9908555	A2.06
4181663	A2.01	9904710	A2.06	9906842	D3.10/1	9908086	D3.10/1	9908604	D3.10
4184167	B1.01	9904722	A2.06	9906843	D3.10	9908087	D3.10	9908604	D3.10/1
4199244	F5.01	9904724	A2.06	9906843	D3.10/1	9908087	D3.10/1	9908658	A2.06
4199734	F4.01/2	9904730	A2.06	9906844	D3.10	9908088	D3.10	9909023	F6.34
4200910	F4.01/2	9904731	A2.06	9906844	D3.10/1	9908088	D3.10/1	9909023	F6.34/3
4200911	F4.01/2	9905030	A2.06	9906845	D3.10	9908089	D3.10	9909137	A2.06
4200912	F4.01/2	9905070	A2.06	9906845	D3.10/1	9908089	D3.10/1	9909320	D3.10
5000897	D3.01	9905071	A2.06	9907066	F6.35/1	9908095	F6.34	9909320	D3.10/1
9900222	F6.34	9905614	D3.10	9907066	F6.35/2	9908274	F6.35/1	9909321	D3.10
9900222	F6.34/3	9905614	D3.10/1	9907200	F6.65	9908313	A2.06	9909362	F6.14
9900233	F6.35/2	9905615	D3.10	9907228	F6.35/1	9908341	F6.29/1	9909362	F6.14/1
9900236	F6.34	9905615	D3.10/1	9907260	A2.06	9908341	F6.29/2	9909407	F6.14
9900377	A2.03	9905617	D3.10	9907261	A2.06	9908341	F6.29/4	9909407	F6.14/1
9900911	F6.29/1	9905617	D3.10/1	9907279	A2.06	9908341	F6.29/6	9909415	F6.14
9900911	F6.29/2	9905619	D3.10	9907311	F6.35	9908343	F6.29	9909415	F6.14/1
9900911	F6.29/4	9905619	D3.10/1	9907780	A2.06	9908343	F6.29/3	9909418	F6.14
9900911	F6.29/6	9905620	D3.10	9907813	A2.06	9908343	F6.29/5	9909423	F6.34
9900911	F6.29/10	9905621	D3.10/1	9907814	A2.06	9908343	F6.29/7	9909479	D3.10/1
9900911	F6.29/12	9905622	D3.10	9907815	A2.06	9908369	F6.65	9909481	D3.10
9900911	F6.29/13	9905622	D3.10/1	9907849	A2.06	9908393	F6.34	9909481	D3.10/1
9900911	F6.29/14	9905623	D3.10	9907861	A2.06	9908393	F6.34/3	9909523	F6.35/1
9902429	F6.14	9905624	D3.10	9907862	A2.06	9908394	F6.34	9909523	F6.35/2
9902429	F6.14/1	9905624	D3.10/1	9908079	D3.10	9908394	F6.34/3	9909953	A2.06
9902821	F6.65	9905628	D3.10/1	9908079	D3.10/1	9908405	F6.32	9910018	F6.14
9903279	F6.65	9905634	D3.10/1	9908080	D3.10	9908406	F6.32	9910018	F6.14/1
9903307	F6.14	9905731	D3.10	9908080	D3.10/1	9908407	F6.32	9910053	A2.03

Bianchina Panoramica e derivati

n. ordinaz.	Sgr.	n. ordinaz.	Sgr.	n. ordinaz.	Sgr.	n. ordinaz.	Sgr.	n. ordinaz.	Sgr.
9910053	A2.03/1	9910584	F6.34/3	9911820	F6.14/1	9913989	A2.03	9915076	F6.29
9910054	A2.03	9910585	F6.34/3	9911957	F6.29	9913989	A2.03/1	9915076	F6.29/3
9910054	A2.03/1	9910589	A2.06	9911957	F6.29/3	9913990	A2.03	9915076	F6.29/5
9910055	A2.03	9910590	A2.06	9911957	F6.29/5	9914072	A2.03	9915076	F6.29/7
9910056	A2.03	9910591	A2.06	9911957	F6.29/7	9914126	F6.32	9915076	F6.29/9
9910057	A2.03	9910592	A2.06	9911957	F6.29/9	9914301	F6.14	9915077	F6.29/5
9910058	A2.03	9910594	A2.06	9911959	F6.35/1	9914301	F6.14/1	9915077	F6.29/7
9910059	A2.03	9910595	A2.06	9911959	F6.35/2	9914304	F6.65	9915078	F6.29/7
9910060	A2.03	9910596	A2.06	9912671	F6.65	9914386	A2.03	9915079	F6.29
9910061	A2.03	9910597	A2.06	9912674	F6.65	9914719	F6.35/2	9915079	F6.29/9
9910062	A2.03	9910598	A2.06	9912675	F6.65	9914720	F6.35/2	9915080	F6.29/3
9910066	A2.03	9910599	A2.06	9912723	F6.14	9914767	F6.29/1	9915090	F6.32/1
9910066	A2.03/1	9910600	A2.06	9912723	F6.14/1	9914767	F6.29/10	9915091	F6.32/1
9910068	A2.03	9910601	A2.06	9912759	F6.14	9914768	F6.29/2	9915095	F6.29
9910069	A2.03	9910602	A2.06	9912759	F6.14/1	9914768	F6.29/14	9915095	F6.29/3
9910159	F6.34	9910603	A2.06	9913064	F6.14/1	9914769	F6.29/1	9915095	F6.29/5
9910372	F6.65	9910604	A2.06	9913304	F6.65	9914769	F6.29/2	9915095	F6.29/7
9910377	F6.65	9910630	A2.06	9913307	F6.65	9914769	F6.29/4	9915095	F6.29/9
9910379	F6.65	9910755	F6.34	9913318	F6.65	9914769	F6.29/6	9915297	F6.34/3
9910380	F6.65	9910905	F6.65	9913319	F6.65	9914770	F6.29/4	9915298	F6.34/3
9910385	F6.65	9910982	F6.65	9913325	F6.65	9914770	F6.29/13	9915299	F6.34/3
9910387	F6.14	9911298	F6.14	9913327	F6.29/1	9914771	F6.29/6	9915300	F6.34/3
9910387	F6.14/1	9911298	F6.14/1	9913327	F6.29/2	9914771	F6.29/12	9915437	F6.29/10
9910431	D3.10/1	9911476	A2.03/1	9913327	F6.29/4	9914772	F6.29/4	9915437	F6.29/12
9910468	F6.14	9911552	F6.14	9913327	F6.29/6	9914772	F6.29/6	9915437	F6.29/13
9910468	F6.14/1	9911552	F6.14/1	9913327	F6.29/10	9914772	F6.29/12	9915437	F6.29/14
9910471	F6.14	9911558	F6.14	9913327	F6.29/12	9914772	F6.29/13	9915438	F6.29/10
9910471	F6.14/1	9911558	F6.14/1	9913327	F6.29/13	9914805	F6.65	9915438	F6.29/12
9910472	F6.14	9911559	F6.14	9913327	F6.29/14	9915041	F6.29/11	9915438	F6.29/13
9910472	F6.14/1	9911559	F6.14/1	9913609	A2.03	9915042	F6.29/11	9915438	F6.29/14
9910473	F6.14	9911560	F6.14	9913609	A2.03/1	9915043	F6.29/11	9915455	F6.29/9
9910473	F6.14/1	9911560	F6.14/1	9913787	F6.65	9915044	F6.29/11	9915489	F6.29/11
9910474	F6.14	9911561	F6.14	9913788	F6.65	9915072	F6.32/1	9915632	F6.34/2
9910474	F6.14/1	9911561	F6.14/1	9913869	F6.35/1	9915073	F6.32/1	9915633	F6.34/2
9910499	F6.34	9911820	F6.14	9913869	F6.35/2	9915075	F6.29/5	9915634	F6.34/2

Bianchina Panoramica e derivati

n. ordinaz.	Sgr.	n. ordinaz.	Sgr.	n. ordinaz.	Sgr.	n. ordinaz.	Sgr.	n. ordinaz.	Sgr.
9915635	F6.34/2	10375101	F6.08	10420305	A2.21	10516870	D3.05	10734201	A2.21
9915832	A2.03/1	10396080	F4.01	10516470	A1.02	10517170	D2.02	10734201	C1.35
9915834	A2.03/1	10396080	F4.01/1	10516470	A4.07	10519201	F6.08	10734201	F2.01
9915941	A2.03	10396080	F4.01/2	10516470	A4.09	10519301	B1.01	10734201	F6.08
9915963	A2.03/1	10396080	F4.01/3	10516470	B2.01	10519301	C1.02	10734301	C1.01
9915964	A2.03/1	10396180	A2.01	10516470	B2.24	10519301	C1.02/1	10734301	C1.01/1
9915965	A2.03/1	10396180	F4.01	10516470	C1.02	10519301	C1.35	10734601	B2.04
9916741	A2.03/1	10396180	F4.01/1	10516470	C1.02/1	10519301	F1.01	10734601	D3.01
10101101	A2.05	10396180	F4.01/2	10516470	D2.02	10519301	F6.08	10734801	B4.01
10115305	A2.21	10396280	E3.01	10516470	E3.01/1	10519401	A3.01	10735880	F6.02
10115405	F4.01	10396280	E3.01/1	10516470	E3.01/2	10519401	A3.01/1	10735880	F6.02/1
10115405	F4.01/1	10396280	E3.01/2	10516470	F6.02	10519401	F1.01	10788811	C1.35
10115405	F4.01/2	10396380	F1.01	10516470	F6.02/1	10519401	F6.02	10788811	F4.01
10115405	F4.01/3	10396380	F4.01	10516470	F6.06	10519401	F6.02/1	10788811	F4.01/1
10158300	A1 07	10396380	F4.01/1	10516470	F6.65	10519601	A0.01	10788811	F4.01/2
10158700	F6.08	10396380	F4.01/2	10516670	A1.03	10519601	A1.07	10788811	F4.01/3
10158901	A1.03	10396180	F4.01/3	10516670	A2.01	10519601	A2.56	10788811	F5.05
10158901	D3.01	10396280	C1.02	10516670	A2.56	10519601	B2.01	10790111	A1.02
10168590	A2.01	10396280	C1.02/1	10516670	A4.07	10519601	B2.07	10791011	D3.01
10170990	A2.01	10396280	E3.01	10516670	B1.01	10519601	C1.35	10791321	D2.02
10170990	A2.02	10396280	E3.01/1	10516670	B4.01	10519601	D2.01	10793311	D3.01
10196901	F6.08	10396280	E3.01/2	10516670	B2.01	10519601	D2.10	10794011	A2.01
10205720	F6.02	10396280	F1.01	10516670	B4.04	10519601	F2.01	10794011	E3.01
10205720	F6.02/1	10396380	F4.01	10516670	C1.01	10520001	D3.05	10794011	F4.01
10205820	A1.06	10396380	F4.01/1	10516670	C1.01/1	10520101	B2.04	10794011	F4.01/1
10263160	A3.01	10396380	F4.01/2	10516670	D2.01	10520101	D2.02	10794011	F4.01/2
10263160	A3.01/1	10396380	F4.01/3	10516670	D2.10	10531700	A4.07	10794011	F4.01/3
10291290	E1.01	10396480	F3.01	10516670	D3.01	10615470	F3.01	10794011	F6.02
10296160	A3.01	10397380	C1.02	10516670	D3.05	10725911	C1.02	10795001	A4.07
10298350	A2.01	10397380	C1.02/1	10516670	F2.01	10725911	C1.02/1	10795001	E1.01
10298460	A3.01/1	10405186	F1.01	10516670	F5.01	10725911	F6.02	10796301	C1.35
10332010	D2.02	10405280	F5.01	10516670	F6.08	10725911	F6.02/1	10796401	D2.02
10332510	F6.14	10405480	F3.01	10516870	A0.01	10729711	F1.01	10796901	F2.01
10332510	F6.14/1	10414170	D2.02	10516870	B2.01	10734101	A2.21	10801910	B2.04
10358611	B2.01	10418305	F5.05	10516870	D3.01	10734101	B1.01	10839610	A1.02

Bianchina Panoramica e derivati

n. ordinaz.	Sgr.	n. ordinaz.	Sgr.	n. ordinaz.	Sgr.	n. ordinaz.	Sgr.	n. ordinaz.	Sgr.
10856290	F4.01	11030321	A1.02	12164711	D3.05	12605270	F4.01	12644401	A2.21
10856290	F4.01/1	11057875	C1.06	12168790	A4.07	12605270	F4.01/1	12644401	F5.05
10856290	F4.01/3	11066675	A1.07	12170690	C1.02	12605270	F4.01/2	12646701	A2.04
10856990	F4.01	11087875	A2.21	12170690	C1.02/1	12605270	F4.01/3	12646701	A2.56
10857790	F4.01/2	11088075	A2.21	12172190	A2.04	12605370	A2.21	12646701	D3.05
10858090	F4.01	11195370	F6.02	12429310	B4.04	12605370	C1.02	12646801	D3.01
10858090	F4.01/1	11195370	F6.02/1	12429310	C1.02	12605370	E3.01	13271601	F6.02
10858090	F4.01/2	11195370	F6.08	12429420	A2.56	12605370	F1.01	13271601	F6.02/1
10858090	F4.01/3	11195370	F6.14	12430220	A1.07	12605370	F5.05	13271801	F4.01/2
10858390	F4.01	11195370	F6.14/1	12430230	B2.01	12605570	A0.01	13271801	F6.08
10858390	F5.01	11195370	F6.34	12554920	A1.05	12605570	A2.04	13274901	F4.01/1
10858390	F5.03	11195470	A2.04	12574111	F6.08	12605570	A2.56	13303611	B2.01
10858390	F5.03/1	11195470	A4.07	12574211	A2.04	12605570	C1.02	13303711	A1.03
10863090	F4.01	11195470	B2.01	12574211	B1.01	12605570	C1.02/1	13313701	F4.01
10863090	F4.01/1	11195470	B2.10	12574211	B2.07	12605570	C1.30	13400275	B2.24
10863090	F4.01/2	11195470	C1.02	12574511	A0.01	12605570	D2.01	13400775	C1.35
10863090	F4.01/3	11195470	C1.02/1	12574511	D3.01	12605670	C1.32	13406911	D3.14
10902021	A2.21	11195470	F5.05	12574711	D3.05	12606970	A1.03	13454310	B2.01
10902021	F6.65	11195470	F6.02	12574711	D2.10	12606970	B2.01	13454510	B2.01
10902121	A2.21	11195470	F6.02/1	12575611	A4.09	12638670	A0.01	13516010	A0.01
10902221	A4.07	11195470	F6.14	12575611	D2.10	12638670	C1.01	13516011	B1.01
10977511	F4.01	11195470	F6.14/1	12575611	F6.02	12638670	C1.01/1	13550101	F6.02
10977511	F4.01/1	11198070	A1.07	12575611	F6.02/1	12639701	A2.04	13550201	A2.21
10977511	F4.01/2	11500110	B2.24	12598070	F4.01/2	12639701	E1.01	13550201	F2.01
10977511	F4.01/3	11500210	B2.01	12599070	A2.21	12642701	C1.35	13550301	C1.35
10977521	A4.07	11903171	A2.01	12605170	A2.01	12642750	B2.04	13550475	A4.09
10977521	B2.01	11944908	F3.01	12605170	E3.01	12642801	A4.07	13819011	F6.02
10977621	C1.35	12056686	F1.01	12605170	F4.01	12642811	F4.01	13823621	A3.01
10979421	A1.06	12056886	F1.01	12605170	F4.01/1	12642811	F4.01/1	13823621	A3.01/1
10979421	C1.02	12056986	F1.01	12605170	F4.01/2	12642811	F4.01/3	13824011	B4.01
10979421	C1.02/1	12164711	A0.01	12605170	F4.01/3	12643701	A2.05	13824121	A4.07
10980810	A1.02	12164711	A1.01	12605270	A2.21	12643701	A4.07	13824211	A4.07
10981221	A2.04	12164711	B2.01	12605270	C1.35	12643701	E1.01	13824221	A4.07
10981620	A1.02	12164711	C1.32	12605270	F1.01	12644301	A0.01	13824321	A4.07
10981620	A2.04	12164711	D3.01	12605270	F2.01	12644301	D3.05	13824321	B1.05

Bianchina Panoramica e derivati

n. ordinaz.	Sgr.	n. ordinaz.	Sgr.	n. ordinaz.	Sgr.	n. ordinaz.	Sgr.	n. ordinaz.	Sgr.
13824321	B2.01	14147590	F4.01/3	15896211	E3.01/2	16100811	C1.02	19052980	E3.01/2
13824521	A1.02	14147595	F4.01/1	15896211	F1.01	16100811	C1.02/1	19053080	A2.01
13824521	A3.01	14147595	F4.01/2	15896211	F3.01	16100811	C1.30	19053080	A2.02
13824521	A3.01/1	14148190	F4.01/1	15896211	F5.01	16100811	D2.01	19053080	C1.02
13824521	B1.01	14148190	F4.01/2	15896211	F6.02	16100811	D2.10	19053080	C1.02/1
13824611	A1.02	14148190	F4.01/3	15896211	F6.02/1	16100811	D3.01	19110094	F1.01
13824611	F1.01	14166070	B1.01	15896218	F3.01	16100811	D3.05	19140190	F1.01
13825011	A1.02	14170370	D3.14	15896411	A2.21	16100811	F2.01	19142090	F4.01/2
13825411	A4.07	14287511	A2.04	15896411	C1.02	16100811	F5.01	19150570	A2.21
13825421	A4.07	14289711	D2.02	15896411	C1.02/1	16102240	A2.56	19155190	F1.01
13825621	A2.56	14289811	D2.02	15896411	F6.02	16102311	A0.01	20419300	B2.24
13825711	A2.56	14289811	F5.05	15896411	F6.02/1	16102311	A2.56	20419310	B2.10
13825711	B2.07	14290021	D2.02	15970521	A0.01	16102311	A4.07	20888670	B2.04
13825711	C1.35	14323613	B2.01	15971621	D3.01	16102311	F6.08	23685431	F1.01
13825721	A2.21	14324101	D2.02	15972621	A0.01	16104111	B2.07	24910341	A2.01
13825821	A2.21	14324411	A1.02	16043321	C1.01	16104111	D2.01	24910451	A1.02
13826311	A2.02	14328401	A1.02	16043530	A1.03	16104111	D2.10	24912551	E3.01
13826611	F3.01	14522421	Z1.01	16043621	A2.56	16105011	D3.05	24912551	E3.01/2
13831801	C1.02/1	14525021	Z1.01	16043621	B2.04	17668601	F4.01/3	24940150	F6.02/1
13831801	E1.01	14528271	Z1.01	16043630	A1.03	17669202	E1.01	29440010	F6.02
13836071	F5.01	14533631	Z1.01	16043821	C1.01/1	17669701	F4.01/3	40000160	A1.03
14043971	D3.14	15186001	A2.21	16043821	D2.01	17670002	C1.01	40000170	A1.02
14044671	D3.14	15186101	A2.21	16043821	D2.10	17670002	E3.01/1	60055388	D3.14
14054911	A1.01	15186101	F2.01	16044121	B4.01	17670002	E3.01/2	60071320	C1.06
14090411	A1.02	15187001	C1.02	16044321	D2.01	17671101	A2.21	60087230	A2.21
14142390	F4.01/1	15187001	C1.02/1	16044621	C1.01/1	17671401	F4.01/1	98090000	F5.03
14142390	F4.01/2	15193511	A4.07	16044721	C1.01	17678701	F4.01/1	98090001	F5.03
14142390	F4.01/3	15611201	F6.32/1	16095911	E1.01	17679601	E1.01		
14143190	F4.01	15896211	A1.02	16100811	A0.01	17680701	F4.01		
14144690	F4.01/1	15896211	A4.07	16100811	A1.07	17680801	F4.01/2		
14144690	F4.01/2	15896211	A4.09	16100811	A2.04	19052880	E3.01		
14144690	F4.01/3	15896211	B2.01	16100811	A2.56	19052880	E3.01/1		
14147590	F4.01	15856211	B2.24	16100811	B1.01	19052880	E3.01/2		
14147590	F4.01/1	15896211	E3.01	16100811	B2.01	19052980	E3.01		
14147590	F4.01/2	15896211	E3.01/1	16100811	B4.04	19052980	E3.01/1		

Bianchina Panoramica e derivati

ERA	VED.	ERA	VED.	ERA	VED.	ERA	VED.	ERA	VED.
370730	4174484	4159154	4180726						
983027	4169720	4161588	4169720						
986897	4058833	4166420	4181663						
1103353	1114064	10298460	10296160						
1103519	1114068	10516670	11198070						
1113548	4058833	10795701	10734201						
4005527	4135279	11198971	4127015						
4012284	4135925	12567420	12554920						
4033666	4135925	13516610	13516011						
4033762	4057904	13824011	10979421						
4043630	4158929	15896211	12574211						
4050539	4165210	16102311	16100811						
4054844	4162944								
4060534	4156930								
4064643	4174485								
4064869	4161986								
4064870	4161987								
4064871	4161988								
4071108	4135924								
4088697	4160924								
4114941	4142061								
4115148	4174484								
4115149	4174485								
4117457	4178038								
4119634	4184167								
4119728	4180726								
4119732	4180719								
4124088	4150570								
4127015	11198971								
4130791	4181663								
4132151	4127153								
4137701	4157329								
4138423	40000160								
4146918	40000170								
4159152	4180719								

- C 2741 4118224
- D 2741 4149757
- C 2741 4136540 (13)
- D 2741 4149959 (13)

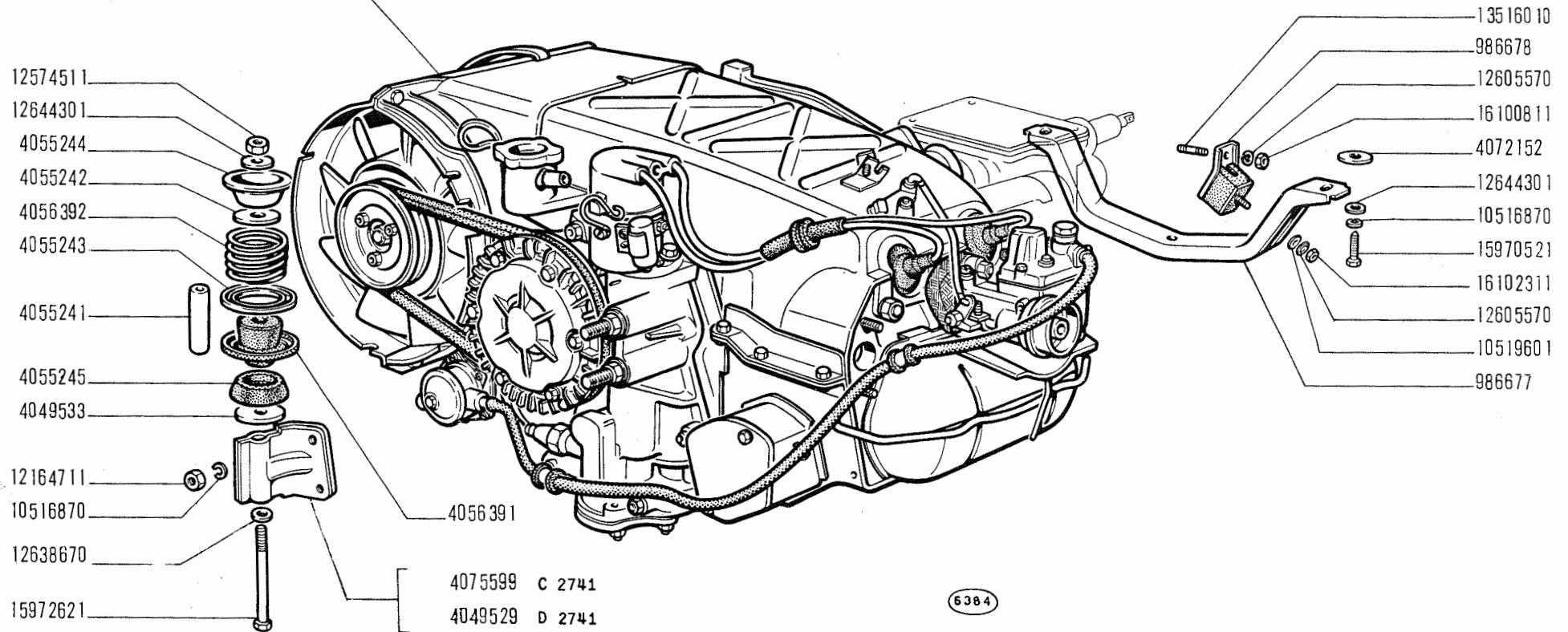

blanchina
panoramica

MOTORE E SUPPORTI GRUPPO MOTOPROPULSORE

- Moteur et supports du groupe propulseur
- Motor und Triebwerkklager

- Engine and Power Plant Supports
- Motor y anclaje de la planta motriz

A0.01

modif.	n. ordinaz.	quant.	Denominazione	Désignation	Benennung	Description	Denominaciones
	986677	1	Traversa	Traverse	Traverse	Cross rail	Travesaño
	986678	2	Tassello elastico	Tampon	Gummistück	Pad	Cojinete
D 2741	4049529	1	Braccio	Bras	Arm	Arm	Brazo
	4049533	1	Rosetta piana	Rondelle	Scheibe	Washer	Arandela
	4055241	1	Distanziale	Entretoise	Abstandstück	Spacer	Separador
	4055242	1	Rosetta piana sup.	Rondelle	Scheibe	Washer	Arandela
	4055243	1	Scodellino inf.	Cuvette	Tellerscheibe	Cup	Platillo
	4055244	1	Scodellino sup.	Cuvette	Tellerscheibe	Cup	Platillo
	4055245	1	Tampone elastico inf.	Tampon	Gummistück	Pad	Cojinete
	4056391	1	Tampone elastico sup.	Tampon	Gummistück	Pad	Cojinete
	4056392	1	Molla	Ressort	Feder	Spring	Muelle
	4072152	2	Piastrina	Cale	Distanzscheibe	Shim	Suplemento
C 2741	4075599	1	Braccio	Bras	Arm	Arm	Brazo
C 2741	4118224	1	Motore	Moteur	Motor	Engine	Motor
C 2741	4136540	1	Motore - 13 -	Moteur	Motor	Engine	Motor
D 2741	4149757	1	Motore	Moteur	Motor	Engine	Motor
D 2741	4149959	1	Motore - 13 -	Moteur	Motor	Engine	Motor
	10516870	4	Rosetta elastica	Rondelle	Sicherungsring	Lockwasher	Arandela elástica
	10519601	2	Rosetta piana	Rondelle	Scheibe	Washer	Arandela
	12164711	2	Dado	Écrou	Mutter	Nut	Tuerca
	12574511	1	Dado autobloccante	Écrou	Mutter	Nut	Tuerca
	12605570	4	Rosetta dentata	Rondelle	Sicherungsring	Lockwasher	Arandela dentada
	12638670	1	Rosetta piana inf.	Rondelle	Scheibe	Washer	Arandela
	12644301	3	Rosetta piana	Rondelle	Scheibe	Washer	Arandela
	13516010	2	Prigioniero	Goujon	Stiftschraube	Stud	Espárrago
	15970521	2	Vite	Vis	Schraube	Screw	Tornillo
	15972621	1	Vite	Vis	Schraube	Screw	Tornillo
	16100811	2	Dado	Écrou	Mutter	Nut	Tuerca
	16102311	2	Dado	Écrou	Mutter	Nut	Tuerca

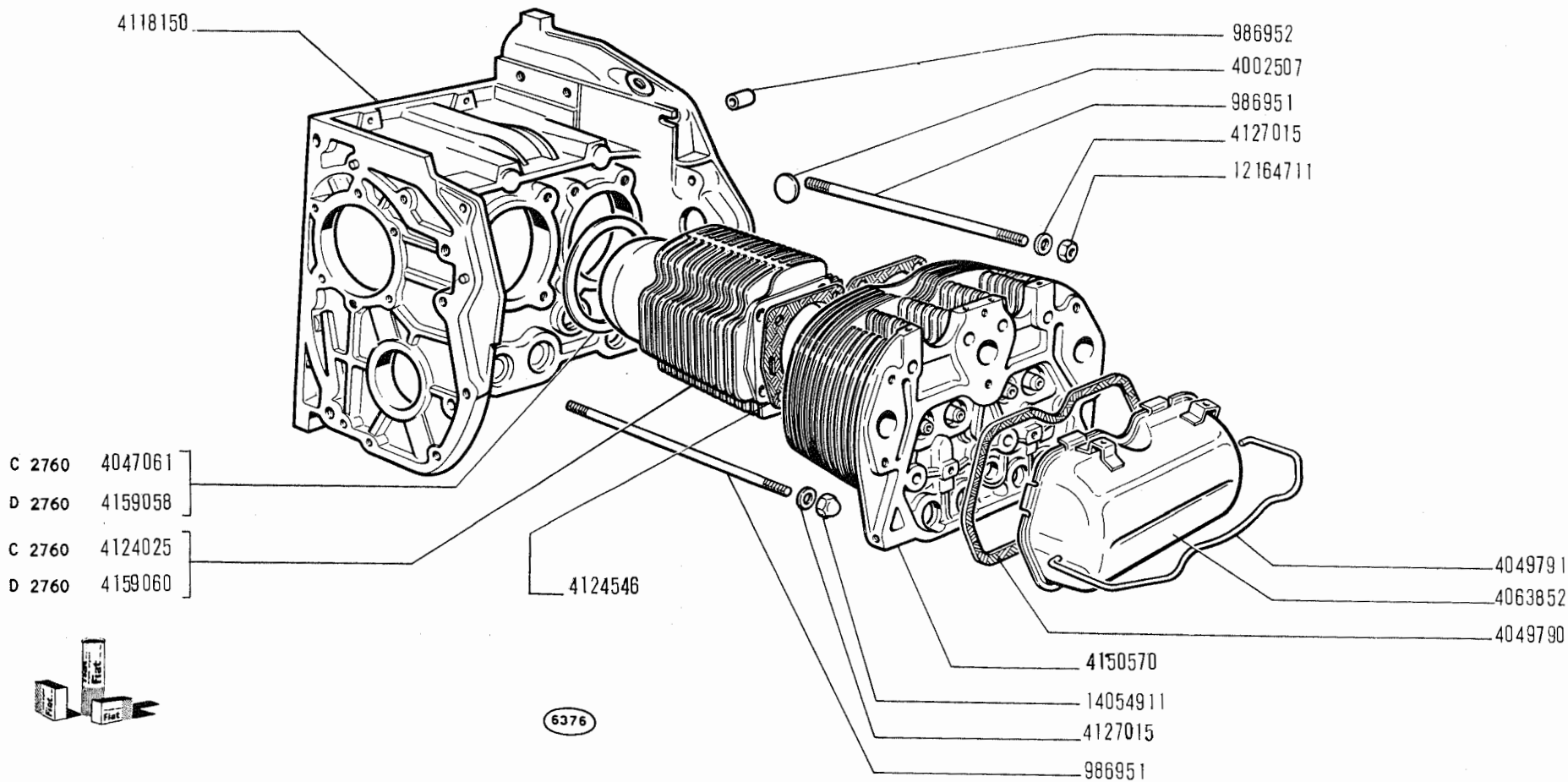

modif.	n. ordinaz.	quant.	Denominazione	Désignation	Benennung	Description	Denominaciones
	986951	8	Prigioniero	Goujon	Stiftschraube	Stud	Espárrago
	986952	2	Grano	Ergot	Passtift	Dowel	Pitón
	4002507	1	Tappo inf.	Bouchon	Stopfen	Plug	Tapón
C 2760	4047061	2	Guarnizione	Joint	Dichtung	Gasket	Junta
	4049790	1	Guarnizione	Joint	Dichtung	Gasket	Junta
	4049791	1	Staffa	Étrier	Halter	Bracket	Soporte
	4063852	1	Coperchio	Couvercle	Deckel	Cover	Tapa
	4118150	1	Basamento compl.	Bâti	Kurbelgehäuse	Crankcase	Bloque de cilindros
C 2760	4124025	2	Cilindro	Cylindre	Zylinder	Cylinder	Cilindro
	4124546	1	Guarnizione	Joint	Dichtung	Gasket	Junta
	4127015	8	Rosetta	Rondelle	Scheibe	Washer	Arandela
	4150570	1	Testa compl.	Culasse	Zylinderkopf	Cylinder head	Culata
D 2760	4159058	2	Guarnizione	Joint	Dichtung	Gasket	Junta
D 2760	4159060	2	Cilindro	Cylindre	Zylinder	Cylinder	Cilindro
	12164711	4	Dado	Écrou	Mutter	Nut	Tuerca
	14054911	4	Dado	Écrou	Mutter	Nut	Tuerca
	900701	S	Guarnizioni	Joints	Dichtungen	Gaskets	Juntas

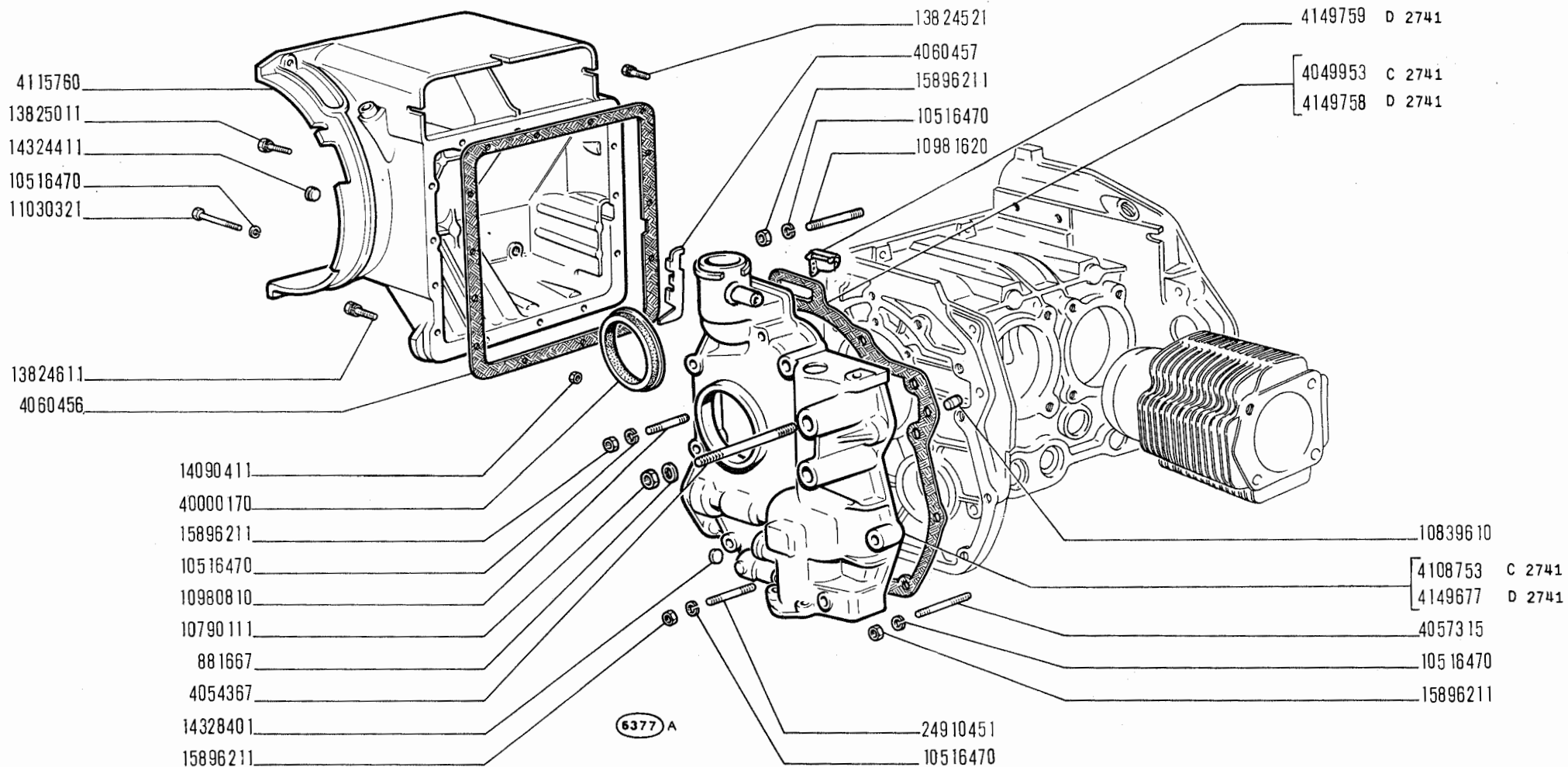

blanchina
panoramica

COPPA E COPERCHI BASAMENTO

- Carter d'huile et couvercles de bâti
- Ölwanne und Deckel des Kurbelgehäuses

- Oil Sump and Crankcase Covers
- Cártar de aceite y tapas del bloque

A1.02

modif.	n. ordinaz.	quant.	Denominazione	Désignation	Benennung	Description	Denominaciones
C 2741	881667	2	Rosetta piana	Rondelle	Scheibe	Washer	Arandela
	4049953	1	Guarnizione	Joint	Dichtung	Gasket	Junta
	4054367	2	Prigioniero	Goujon	Stiftschraube	Stud	Espárrago
	4057315	1	Prigioniero	Goujon	Stiftschraube	Stud	Espárrago
C 2741	4060456	1	Guarnizione	Joint	Dichtung	Gasket	Junta
	4060457	1	Diaframma	Diaphragme	Membran	Diaphragm	Diafragma
	4108753	1	Scatola compl.	Carter	Gehäuse	Case	Caja
	4115760	1	Coppa	Carter	Ölwanne	Sump	Cárter
D 2741	4149677	1	Scatola compl.	Carter	Gehäuse	Case	Cárter
D 2741	4149758	1	Guarnizione	Joint	Dichtung	Seal	Junta
D 2741	4149759	1	Diaframma compl.	Diaphragme	Membran	Diaphragm	Diafragma
	10516470	9	Rosetta elastica	Rondelle	Sicherungsring	Lockwasher	Arandela elástica
	10790111	2	Dado	Écrou	Mutter	Nut	Tuerca
	10839610	2	Grano	Ergot	Passtift	Dowel	Pitón
	10980810	5	Prigioniero	Goujon	Stiftschraube	Stud	Espárrago
	10981620	1	Prigioniero	Goujon	Stiftschraube	Stud	Espárrago
	11030321	1	Vite lunga	Vis	Schraube	Screw	Tornillo
	13824521	5	Vite corta	Vis	Schraube	Screw	Tornillo
	13824611	6	Vite inf.	Vis	Schraube	Screw	Tornillo
	13825011	2	Vite media	Vis	Schraube	Screw	Tornillo
	14090411	6	Dado	Écrou	Mutter	Nut	Tuerca
	14324411	1	Tappo	Bouchon	Stopfen	Plug	Tapón
	14328401	1	Tappo	Bouchon	Stopfen	Plug	Tapón
	15896211	8	Dado	Écrou	Mutter	Nut	Tuerca
	24910451	1	Prigioniero	Goujon	Stiftschraube	Stud	Espárrago
	40000170	1	Anello tenuta	Joint	Dichtring	Seal	Junta

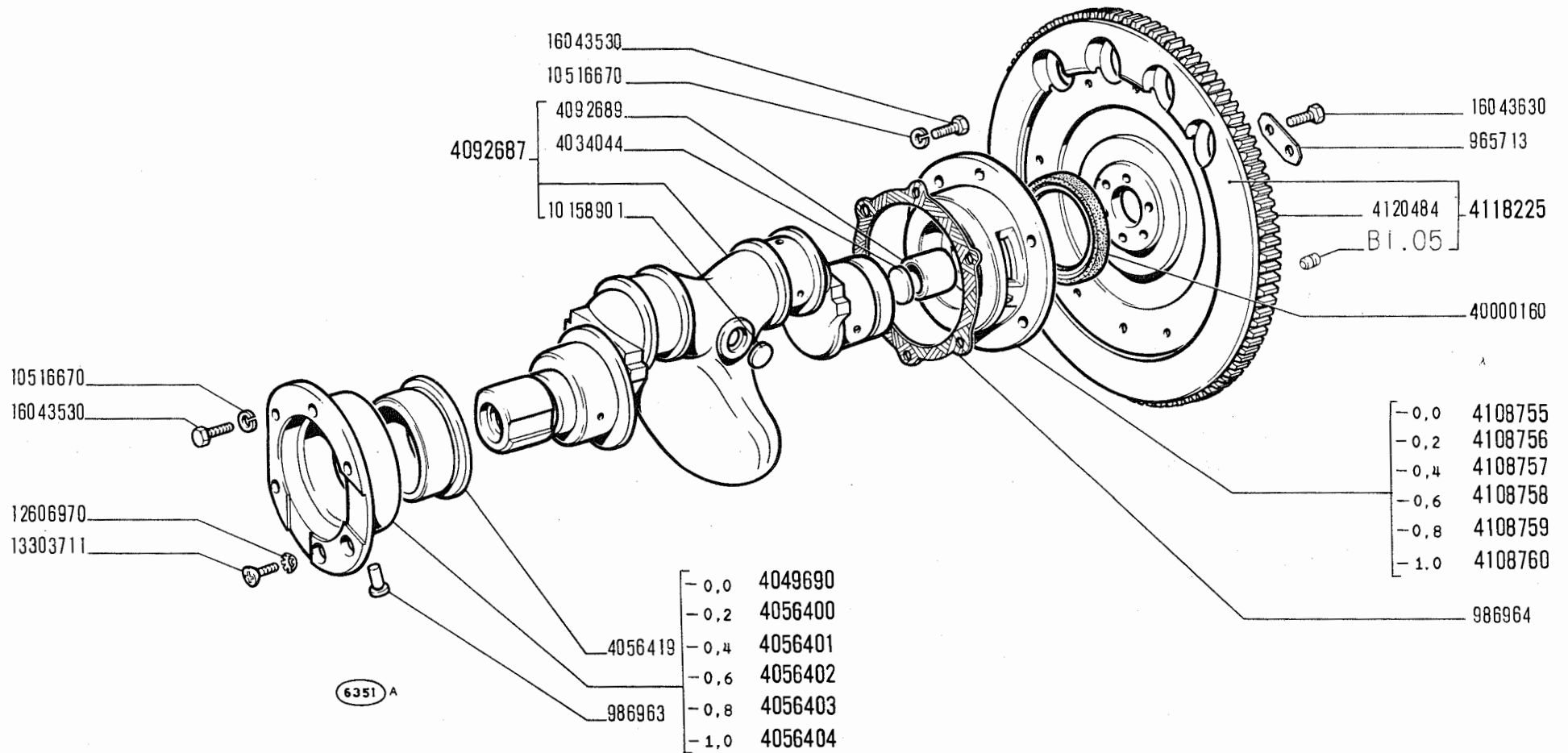

ALBERO E VOLANO MOTORE

- Vilebrequin et volant moteur
- Kurbelwelle und Schwungrad

- Crankshaft and Flywheel
- Cigüeñal y volante

A1.03

modif.	h. ordinaz.	quant.	Denominazione	Désignation	Benennung	Description	Denominaciones
	965713	3	Piastrina sicurezza	Plaquette frein	Sicherungsblech	Lockplate	Placa de freno
	986963	1	Grano	Ergot	Passtift	Dowel	Pitón
	986964	1	Guarnizione	Joint	Dichtung	Gasket	Junta
	4034044	1	Tappo	Bouchon	Stopfen	Plug	Tapón
	4049690	1	Supporto compl.	Support	Lager	Support	Soporte
	4056400	1	Supporto compl. - 0,2	Support	Lager	Support	Soporte
	4056401	1	Supporto compl. - 0,4	Support	Lager	Support	Soporte
	4056402	1	Supporto compl. - 0,6	Support	Lager	Support	Soporte
	4056403	1	Supporto compl. - 0,8	Support	Lager	Support	Soporte
	4056404	1	Supporto compl. - 1,0	Support	Lager	Support	Soporte
	4056419	1	Cuscinetto - 1,0	Coussinet	Lagerschale	Bearing	Cojinete
	4092687	1	Albero compl.	Vilebrequin	Kurbelwelle	Crankshaft	Cigüeñal
	4092689	1	Boccola	Douille	Büchse	Bush	Casquillo
	4108755	1	Supporto	Support	Lager	Support	Soporte
	4108756	1	Supporto - 0,2	Support	Lager	Support	Soporte
	4108757	1	Supporto - 0,4	Support	Lager	Support	Soporte
	4108758	1	Supporto - 0,6	Support	Lager	Support	Soporte
	4108759	1	Supporto - 0,8	Support	Lager	Support	Soporte
	4108760	1	Supporto - 1,0	Support	Lager	Support	Soporte
	4118225	1	Volano compl.	Volant moteur	Schwungrad	Flywheel	Volante
	4120484	1	Corona dentata	Couronne dentée	Zahnkranz	Ring gear	Corona dentada
	10158901	2	Tappo	Bouchon	Stopfen	Plug	Tapón
	10516670	10	Rosetta elastica	Rondelle	Sicherungsring	Lockwasher	Arandela elástica
	12606970	2	Rosetta dentata	Rondelle	Sicherungsring	Lockwasher	Arandela dentada
	13303711	2	Vite	Vis	Schraube	Screw	Tornillo
	16043530	10	Vite	Vis	Schraube	Screw	Tornillo
	16043630	6	Vite	Vis	Schraube	Screw	Tornillo
	40000160	1	Anello tenuta	Joint	Dichtring	Seal	Junta

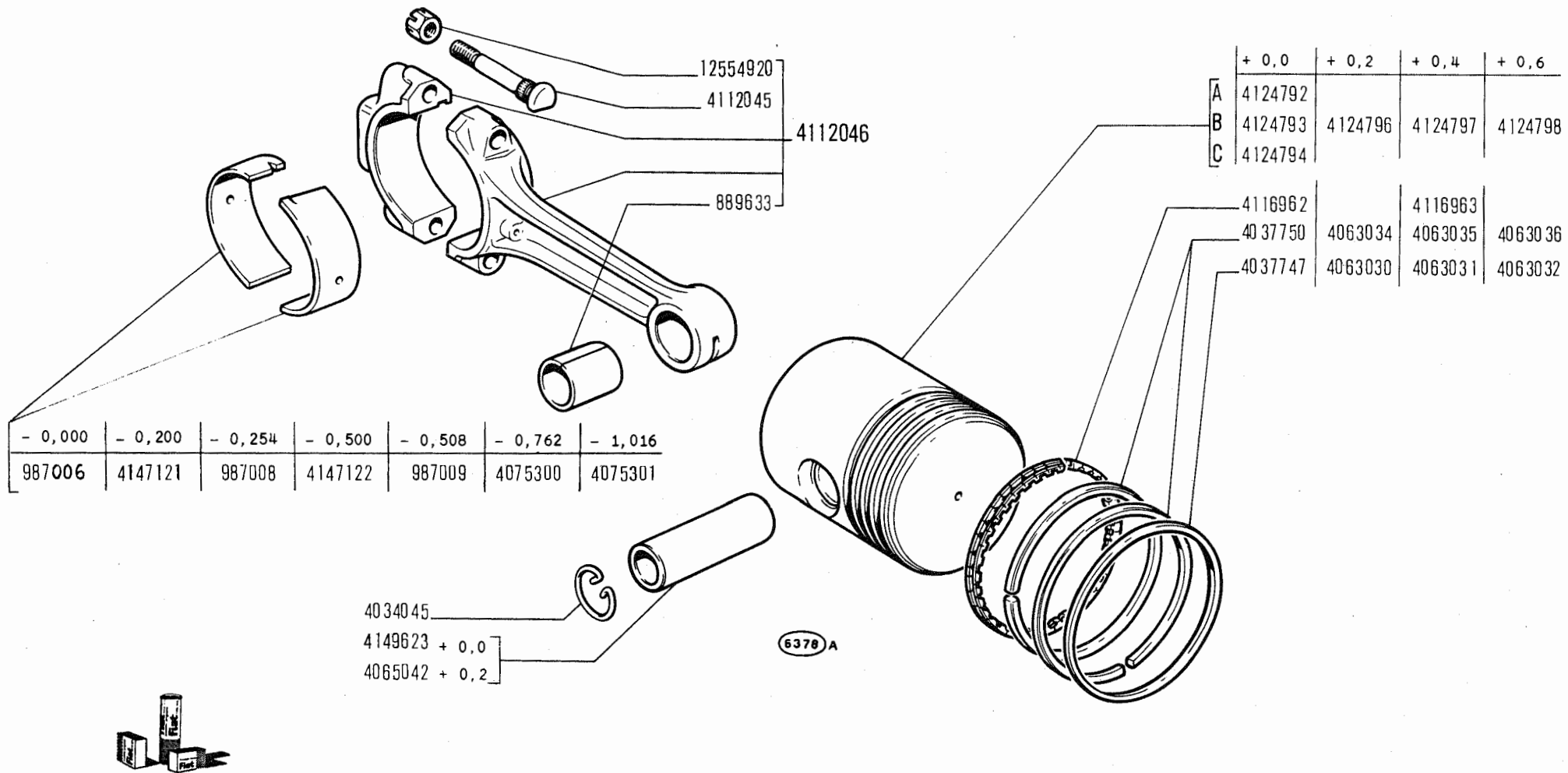

modif.	n. ordinaz.	quant.	Denominazione	Désignation	Benennung	Description	Denominaciones
	889633	2	Boccola	Douille	Büchse	Bush	Casquillo
	987006	4	Semicuscinetto	Demi-coussinet	Schalenhälfte	Half-bearing	Cojinete
	987008	4	Semicuscinetto - 0,254	Demi-coussinet	Schalenhälfte	Half-bearing	Cojinete
	987009	4	Semicuscinetto - 0,508	Demi-coussinet	Schalenhälfte	Half-bearing	Cojinete
	4034045	4	Anello sicurezza	Arrêtoir	Sicherungsring	Lockring	Anillo elástico
	4037747	2	Anello stantuffo	Segment	Kolbenring	Ring	Aro de émbolo
	4037750	4	Anello raschiaolio	Racleur	Ölabstreifring	Oilscraper ring	Aro de engrase
	4063030	2	Anello stantuffo + 0,2	Segment	Kolbenring	Ring	Aro de émbolo
	4063031	2	Anello stantuffo + 0,4	Segment	Kolbenring	Ring	Aro de émbolo
	4063032	2	Anello stantuffo + 0,6	Segment	Kolbenring	Ring	Aro de émbolo
	4063034	4	Anello raschiaolio + 0,2	Racleur	Ölabstreifring	Oilscraper ring	Aro de engrase
	4063035	4	Anello raschiaolio + 0,4	Racleur	Ölabstreifring	Oilscraper ring	Aro de engrase
	4063036	4	Anello raschiaolio + 0,6	Racleur	Ölabstreifring	Oilscraper ring	Aro de engrase
	4065042	2	Perno + 0,2	Axe	Bolzen	Pin	Eje
	4075300	4	Semicuscinetto - 0,762	Demi-coussinet	Schalenhälfte	Half-bearing	Cojinete
	4075301	4	Semicuscinetto - 1,016	Demi-coussinet	Schalenhälfte	Half-bearing	Cojinete
	4112045	4	Bullone per biella	Boulon	Pleuelschraube	Bolt	Tornillo
	4112046	2	Biella compl.	Bielle	Pleuelstange	Connecting rod	Biela
	4116962	2	Anello con feritoie	Racleur	Ölabstreifring	Oilscraper ring	Aro de engrase
	4116963	2	Anello con feritoie + 0,4	Racleur	Ölabstreifring	Oilscraper ring	Aro de engrase
	4124792	2	Stantuffo, classe A	Piston, classe A	Kolben, Klasse A	Piston, class A	Émbolo, classe A
	4124793	2	Stantuffo, classe B	Piston, classe B	Kolben, Klasse B	Piston, class B	Émbolo, classe B
	4124794	2	Stantuffo, classe C	Piston, classe C	Kolben, Klasse C	Piston, class C	Émbolo, classe C
	4124796	2	Stantuffo + 0,2	Piston	Kolben	Piston	Émbolo
	4124797	2	Stantuffo + 0,4	Piston	Kolben	Piston	Émbolo
	4124798	2	Stantuffo + 0,6	Piston	Kolben	Piston	Émbolo
	4147121	2	Semicuscinetto - 0,2 -	Demi-coussinet	Schalenhälfte	Half-bearing	Cojinete
	4147122	2	Semicuscinetto - 0,5 -	Demi-coussinet	Schalenhälfte	Half-bearing	Cojinete
	4149623	2	Perno	Axe	Bolzen	Pin	Eje
	12554920	4	Dado	Écrou	Mutter	Nut	Tuerca
	902017	S	Stantuffo, anelli e perno, classe A	Piston, segments et axe, classe A	Kolben, Ringe u. Bolzen, Klasse A	Piston, rings and pin, class A	Émbolo, aros y bulón, classe A

modif.	n. ordinaz.	quant.	Denominazione	Désignation	Benennung	Description	Denominaciones
	902018	S	Stantuffo, anelli e perno, classe B	Piston, segments et axe, classe B	Kolben, Ringe u. Bolzen, Klasse B	Piston, rings and pin, class B	Émbolo, aros y bulón, clase B
	902019	S	Stantuffo, anelli e perno, classe C	Piston, segments et axe, classe C	Kolben, Ringe u. Bolzen, Klasse C	Piston, rings and pin, class C	Émbolo, aros y bulón, clase C
	902020	S	Stantuffi, anelli e perni + 0,2	Pistons, segments, axes	Kolben, Ringe u. Bolzen	Pistons, rings and pins	Émbolos, aros y bulones
	902021	S	Stantuffi, anelli e perni + 0,4	Pistons, segments, axes	Kolben, Ringe u. Bolzen	Pistons, rings and pins	Émbolos, aros y bulones
	902022	S	Stantuffi, anelli e perni + 0,6	Pistons, segments, axes	Kolben, Ringe u. Bolzen	Pistons, rings and pins	Émbolos, aros y bulones
	902065	S	Anelli stantuffo	Segments	Kolbenringe	Rings	Aros de émbolo
	902066	S	Anelli stantuffo + 0,2	Segments	Kolbenringe	Rings	Aros de émbolo
	902067	S	Anelli stantuffo + 0,4	Segments	Kolbenringe	Rings	Aros de émbolo
	902068	S	Anelli stantuffo + 0,6	Segments	Kolbenringe	Rings	Aros de émbolo

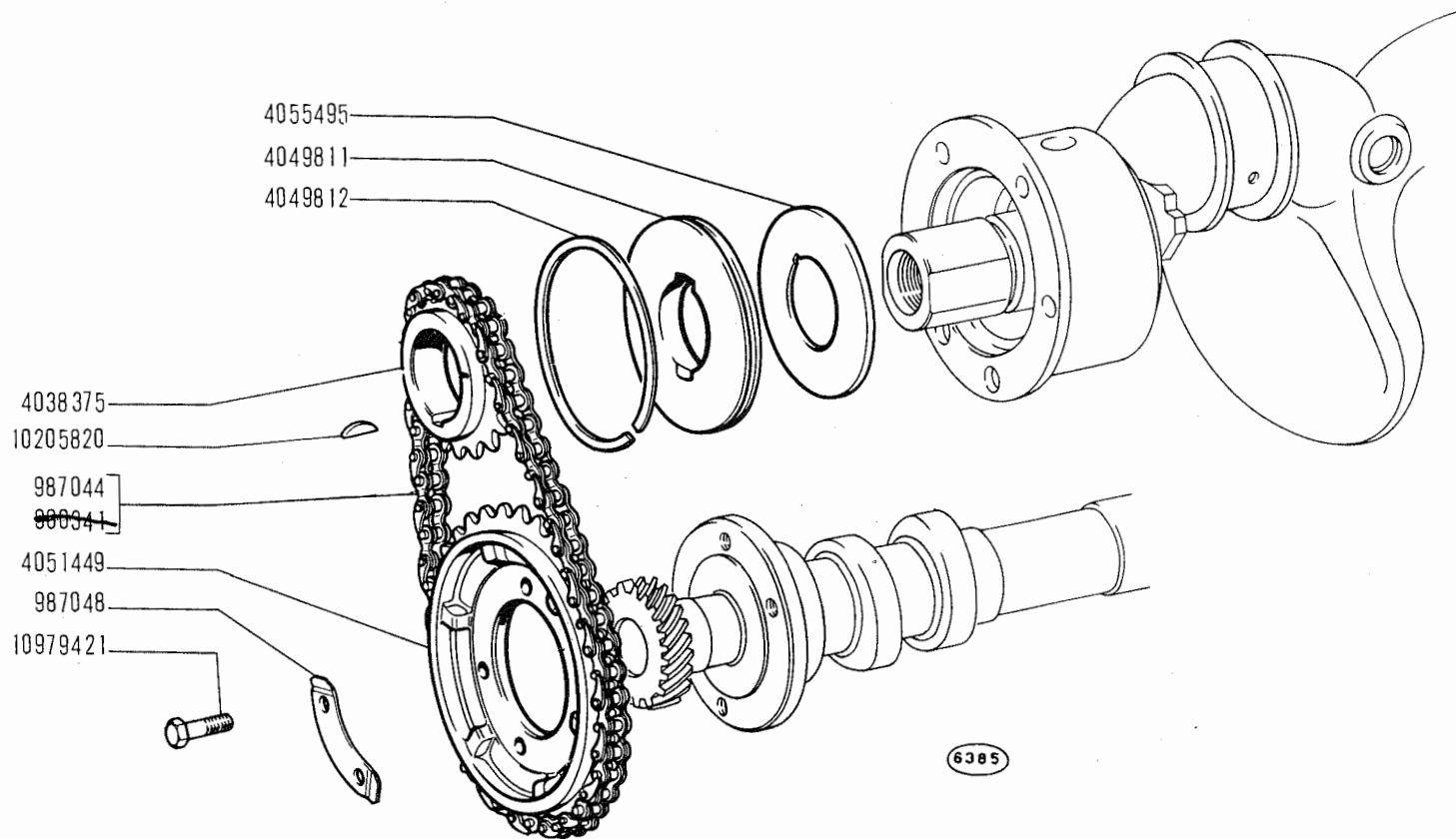

COMANDO DISTRIBUZIONE

- *Commande de distribution*
- *Steuerungsantrieb*

- *Camshaft Drive*
- *Piñones de la distribución*

modif.	n. ordinaz.	quant.	Denominazione	Désignation	Benennung	Description	Denominaciones
	900341	1	Catena - maggiorata -	Chaîne	Kette	Chain	Cadena
	987044	1	Catena	Chaîne	Kette	Chain	Cadena
	987048	2	Piastrina sicurezza	Plaquette frein	Sicherungsblech	Lockplate	Placa de freno
	4038375	1	Ingranaggio conduttore	Pignon	Zahnrad	Gear	Piñón
	4049811	1	Disco distanziale	Disque	Scheibe	Plate	Disco
	4049812	1	Anello sicurezza	Arrêtoir	Sicherungsring	Lockring	Anillo elástico
	4051449	1	Ingranaggio condotto	Pignon	Zahnrad	Gear	Piñón
	4055495	1	Disco distanziale	Disque	Scheibe	Plate	Disco
	10205820	1	Linguetta	Linguet	Scheibenfeder	Key	Chaveta
	10979421	4	Vite	Vis	Schraube	Screw	Tornillo

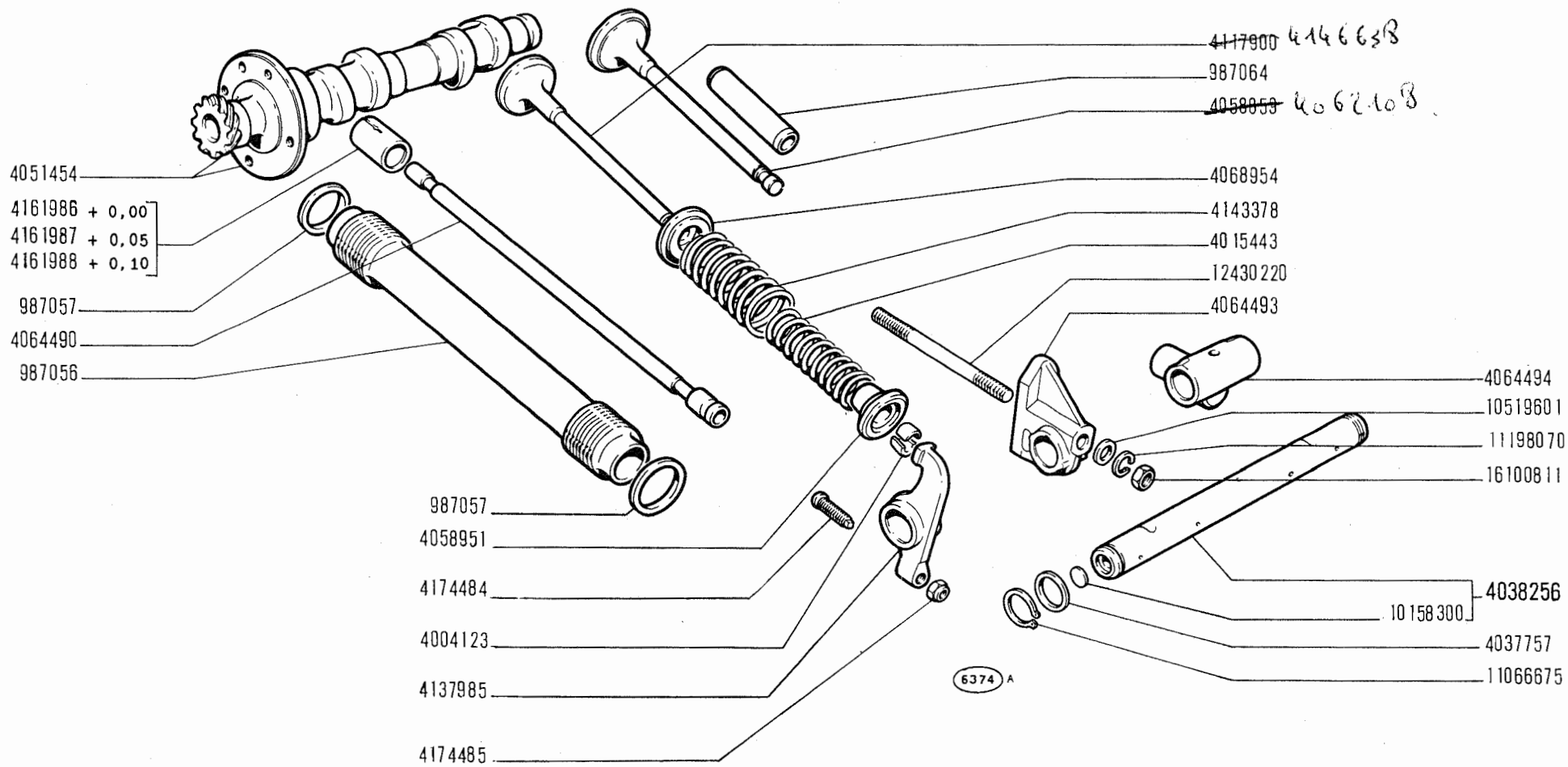

blanchina
panoramica

● Distribution
● Steuerung

DISTRIBUZIONE

● Valve Gear
● Distribución

A1.07

modif.	n. ordinaz.	quant.	Denominazione	Désignation	Benennung	Description	Denominaciones
	987056	4	Astuccio	Étui	Hülse	Casing	Tubo
	987057	8	Anello tenuta	Joint	Dichtring	Seal	Junta
	987064	4	Guida valvole	Guide-soupape	Ventilführung	Valve guide	Guía de válvula
	4004123	8	Semicono	Demi-cône	Kegelstück	Lock cone	Chaveta cónica
	4015443	4	Molla int.	Ressort	Feder	Spring	Muelle
	4037757	2	Rosetta	Rondelle	Scheibe	Washer	Arandela
	4038256	1	Albero compl.	Arbre	Welle	Shaft	Árbol
	4051454	1	Albero eccentrici	Arbre	Welle	Camshaft	Árbol
	4058859	2	Valvola aspirazione	Soupape	Ventil	Valve	Válvula
	4058951	4	Scodellino sup.	Cuvette	Tellerscheibe	Cup	Platillo
	4064490	4	Asta	Tige	Stange	Rod	Varilla
	4064493	2	Supporto	Support	Lager	Support	Soporte
	4064494	1	Distanziale	Entretoise	Abstandstück	Spacer	Separador
	4068954	4	Scodellino inf.	Cuvette	Tellerscheibe	Cup	Platillo
	4117900	2	Valvola scarico	Soupape	Ventil	Valve	Válvula
	4137985	4	Bilanciere	Culbuteur	Kipphebel	Rocker	Balancín
	4143378	4	Molla est.	Ressort	Feder	Spring	Muelle
	4161986	4	Punteria	Poussoir	Stößel	Tappet	Empujador
	4161987	4	Punteria + 0,05	Poussoir	Stößel	Tappet	Empujador
	4161988	4	Punteria + 0,10	Poussoir	Stößel	Tappet	Empujador
	4174484	4	Vite registro	Vis	Schraube	Screw	Tornillo
	4174485	4	Dado	Écrou	Mutter	Nut	Tuerca
	10158300	2	Tappo	Bouchon	Stopfen	Plug	Tapón
	10519601	2	Rosetta piana	Rondelle	Scheibe	Washer	Arandela
	11066675	2	Anello sicurezza	Arrêtoir	Sicherungsring	Lockring	Anillo elástico
	11198070	2	Rosetta elastica	Rondelle	Sicherungsring	Lockwasher	Arandela elástica
	12430220	2	Prigioniero	Goujon	Stiftschraube	Stud	Espárrago
	16100811	2	Dado	Écrou	Mutter	Nut	Tuerca

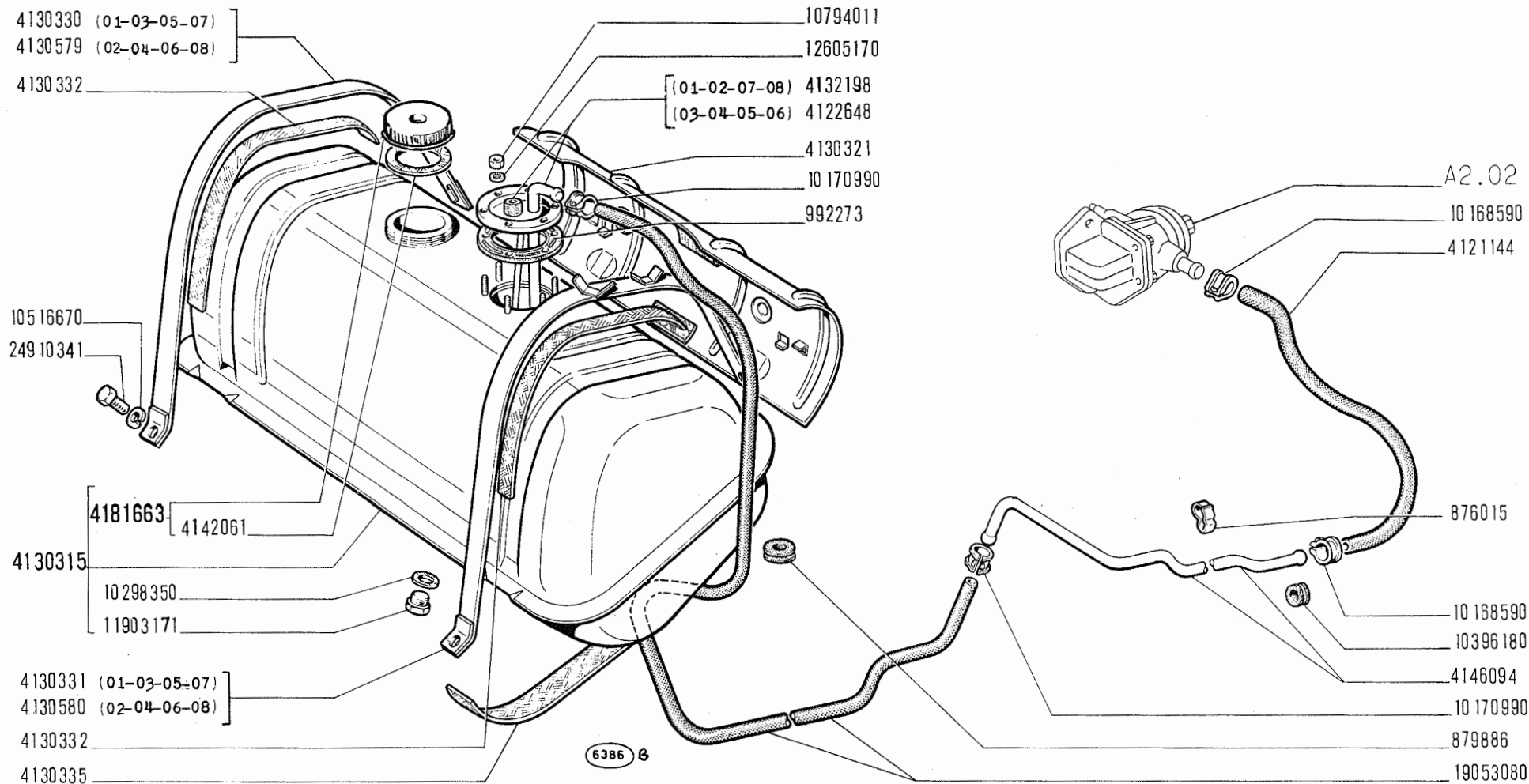

SERBATOIO COMBUSTIBILE E TUBAZIONI

- Réservoir et canalisations combustible
- Kraftstofftank und Leitungen

- Fuel Tank and Lines
- Depósito de combustible y tuberías

modif.	n. ordinaz.	quanc.	Denominazione	Désignation	Benennung	Description	Denominaciones
	876015	1	Staffetta	Collier	Schelle	Retainer	Abrazadera
	879886	1	Guarnizione	Bague	Ring	Ring	Guarnición
	992273	1	Guarnizione	Joint	Dichtung	Gasket	Junta
	4121144	1	Tubo flessibile	Tuyau	Schlauch	Hose	Tubo flexible
	4122648	1	Comando indicatore livello-03-04-05-06-	Comande de jauge	Standgeber	Sending unit	Indicador de nivel
	4130315	1	Serbatoio compl.	Réservoir	Behälter	Tank	Depósito
	4130321	1	Riparo	Protection	Abdeckung	Protection	Defensa
	4130330	1	Nastro d - 01 - 03 - 05 - 07 -	Ruban	Band	Strap	Abrazadera
	4130331	1	Nastro s - 01 - 03 - 05 - 07 -	Ruban	Band	Strap	Abrazadera
	4130332	2	Guarnizione	Caoutchouc	Gummiband	Lining	Goma
	4130335	2	Feltro	Feutre	Filz	Felt	Fieltro
	4130579	1	Nastro d - 02 - 04 - 06 - 08 -	Ruban	Band	Strap	Abrazadera
	4130580	1	Nastro s - 02 - 04 - 06 - 08 -	Ruban	Band	Strap	Abrazadera
	4132198	1	Comando indicatore livello-01-02-07-08-	Comande de jauge	Standgeber	Sending unit	Indicador de nivel
	4142061	1	Guarnizione	Joint	Dichtring	Gasket	Junta
	4146094	1	Tubo intermedio	Tuyau	Rohr	Pipe	Tubo
	4181663	1	Tappo compl.	Bouchon	Schraubdeckel	Cap	Tapón
	10168590	2	Collare	Collier	Schelle	Collar	Abrazadera
	10170990	2	Collare	Collier	Schelle	Collar	Abrazadera
	10298350	1	Guarnizione	Joint	Dichtring	Gasket	Junta
	10396180	1	Anello isolante	Bague	Ring	Ring	Guarnición
	10516670	2	Rosetta elastica	Rondelle	Sicherungsring	Lockwasher	Arandela elástica
	10794011	6	Dado	Écrou	Mutter	Nut	Tuerca
	11903171	1	Tappo	Bouchon	Stopfen	Plug	Tapón
	12605170	6	Rosetta dentata	Rondelle	Sicherungsring	Lockwasher	Arandela de freno
	19053080	m	Tubo 5 × 9	Tuyau	Schlauch	Hose	Tubo
	24910341	2	Vite	Vis	Schraube	Screw	Tornillo

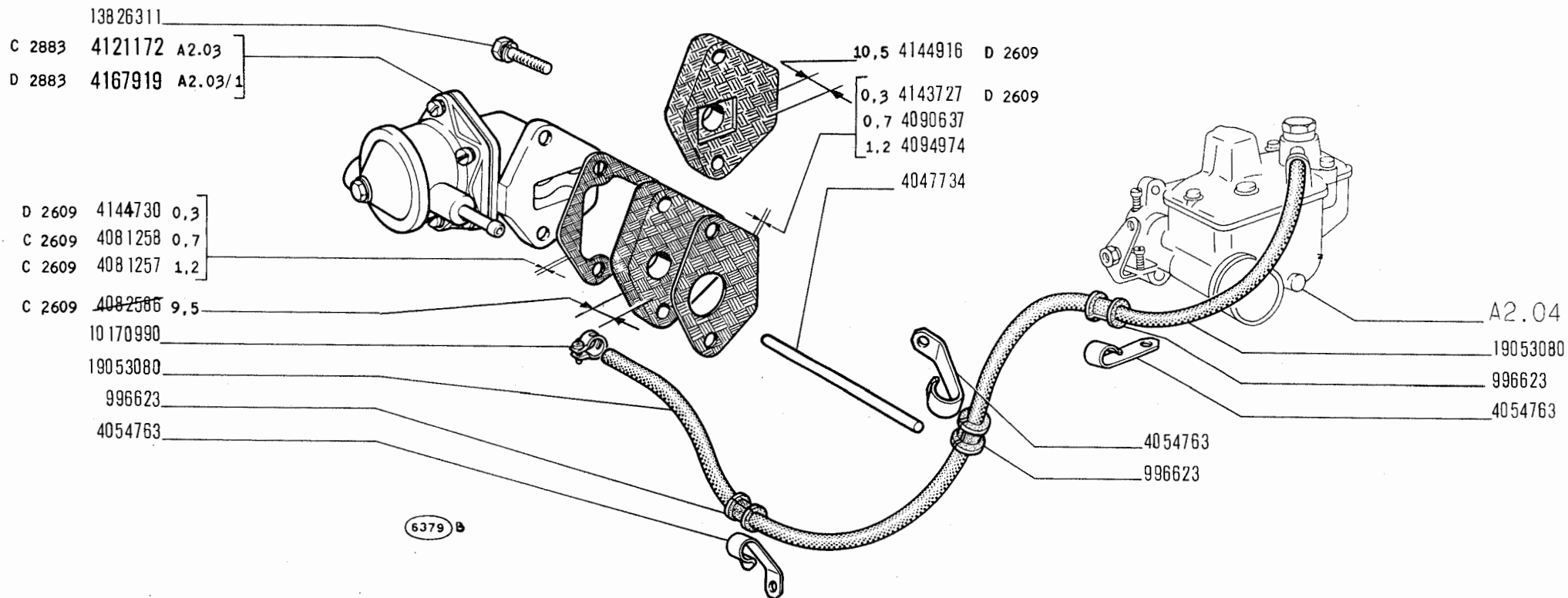

POMPA ALIMENTAZIONE E TUBAZIONI

- Pompe et canalisations d'alimentation
- Kraftstoffpumpe und Leitungen

- Fuel Pump and Lines
- Bomba de alimentación y tuberías

modif.	n. ordinaz.	quant.	Denominazione	Désignation	Benennung	Description	Denominaciones
	996623	3	Anello gomma	Bague	Ring	Ring	Guarnición
	4047734	1	Puntalino	Tige	Druckstange	Rod	Vástago
	4054763	3	Staffa	Collier	Schelle	Retainer	Abrazadera
C 2609	4081257	1	Guarnizione sp. 1,2	Joint	Dichtung	Gasket	Junta
C 2609	4081258	1	Guarnizione sp. 0,7	Joint	Dichtung	Gasket	Junta
C 2609	4082586	1	Isolante sp. 9,5	Isolant	Isolierung	Insulator	Aislador
	4090637	1	Guarnizione sp. 0,7	Joint	Dichtung	Gasket	Junta
	4094974	1	Guarnizione sp. 1,2	Joint	Dichtung	Gasket	Junta
C 2883	4121172	1	Pompa compl. - B.C.D.	Pompe	Pumpe	Pump	Bomba
D 2609	4143727	1	Guarnizione sp. 0,3	Joint	Dichtung	Gasket	Junta
D 2609	4144730	1	Guarnizione sp. 0,3	Joint	Dichtung	Gasket	Junta
D 2609	4144916	1	Isolante sp. 10,5	Isolant	Isolierung	Insulator	Aislador
D 2883	4167919	1	Pompa compl. - B.C.D.	Pompe	Pumpe	Pump	Bomba
	10170990	2	Collare	Collier	Schelle	Collar	Abrazadera
	13826311	2	Vite	Vis	Schraube	Screw	Tornillo
	19053080	m	Tube 5 x 9 x 780	Tuyau	Schlauch	Hose	Tube

9910053

9900377

9910054

9913989

9910055

C 2603 9914386

D 2603 9915941

9913990

9914072

9910062

9910061

9910060

9910058

9910059

9910057

9910056

C 2603

9910066

9913609

9910069

9910068

6271

POMPA ALIMENTAZIONE 4121172 (B. C. D.)

**blanchina
panoramica**

- Pompe d'alimentation
- Kraftstoffpumpe

- Fuel Pump
- Bomba de alimentación

A2.03

modif.	n. ordinaz.	quant.	Denominazione	Désignation	Benennung	Description	Denominaciones
	9900377	1	Rosetta tenuta	Joint	Dichtring	Gasket	Junta
	9910053	1	Vite	Vis	Schraube	Screw	Tornillo
	9910054	1	Coperchio	Couvercle	Deckel	Cover	Tapa
	9910055	1	Filtro	Filter	Filter	Strainer	Filtro
C 2603	9910056	2	Molla	Ressort	Feder	Spring	Muelle
C 2603	9910057	2	Valvola	Soupape	Ventil	Valve	Válvula
C 2603	9910058	2	Piattello	Coupelle	Tellerscheibe	Plate	Platillo
C 2603	9910059	2	Rosetta tenuta	Joint	Dichtring	Gasket	Junta
C 2603	9910060	2	Coperchio	Couvercle	Deckel	Cover	Tapa
C 2603	9910061	2	Vite	Vis	Schraube	Screw	Tornillo
	9910062	1	Corpo inf.	Corps	Gehäuse	Body	Cuerpo
	9910066	1	Molla	Ressort	Feder	Spring	Muelle
	9910068	1	Perno	Axe	Bolzen	Pin	Eje
	9910069	2	Rosetta piana	Rondelle	Scheibe	Washer	Arandela
	9913609	1	Leva comando	Levier	Hebel	Lever	Palanca
	9913989	5	Vite	Vis	Schraube	Screw	Tornillo
	9913990	1	Membrana	Membrane	Membran	Diaphragm	Membrana
	9914072	1	Molla	Ressort	Feder	Spring	Muelle
C 2603	9914386	1	Corpo sup.	Corps	Gehäuse	Body	Cuerpo
D 2603	9915941	1	Corpo sup.	Corps	Gehäuse	Body	Cuerpo

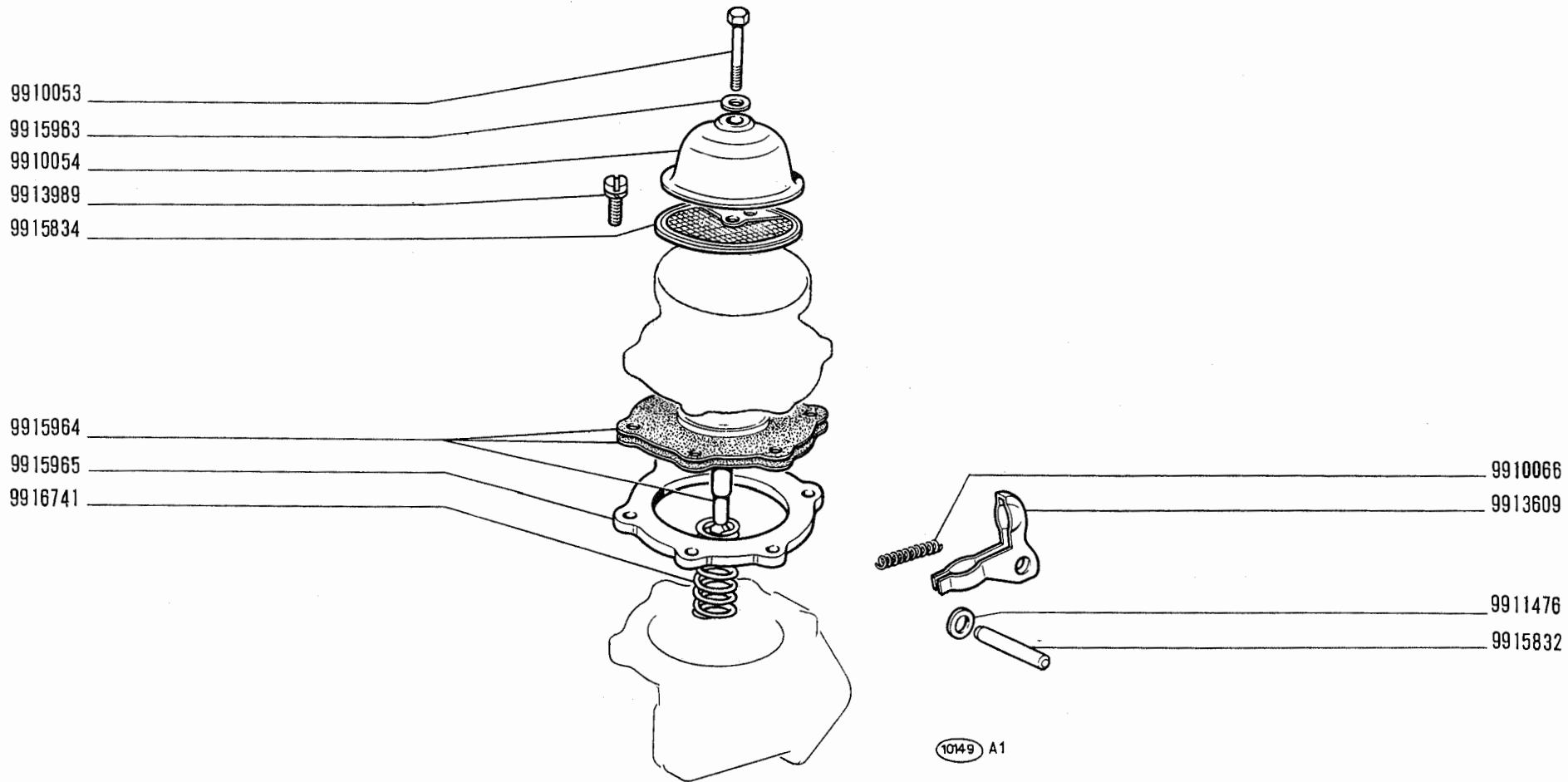

modif.	n. ordinaz.	quant.	Denominazione	Désignation	Benennung	Description	Denominaciones
	9910053	1	Vite	Vis	Schraube	Screw	Tornillo
	9910054	1	Coperchio	Couvercle	Deckel	Cover	Tapa
	9910066	1	Molla	Ressort	Feder	Spring	Muelle
	9911476	1	Rosetta piana	Rondelle	Scheibe	Washer	Arandela
	9913609	1	Leva	Levier	Hebel	Lever	Palanca
	9913989	6	Vite	Vis	Schraube	Screw	Tornillo
	9915832	1	Perno	Axe	Bolzen	Pin	Eje
	9915834	1	Filtro	Filtre	Filter	Strainer	Filtro
	9915963	1	Rosetta tenuta	Joint	Dichtring	Seal	Junta
	9915964	1	Membrana	Membrane	Membran	Diaphragm	Membrana
	9915965	1	Distanziale	Entretoise	Abstandstück	Spacer	Separador
	9916741	1	Molla	Ressort	Feder	Spring	Muelle

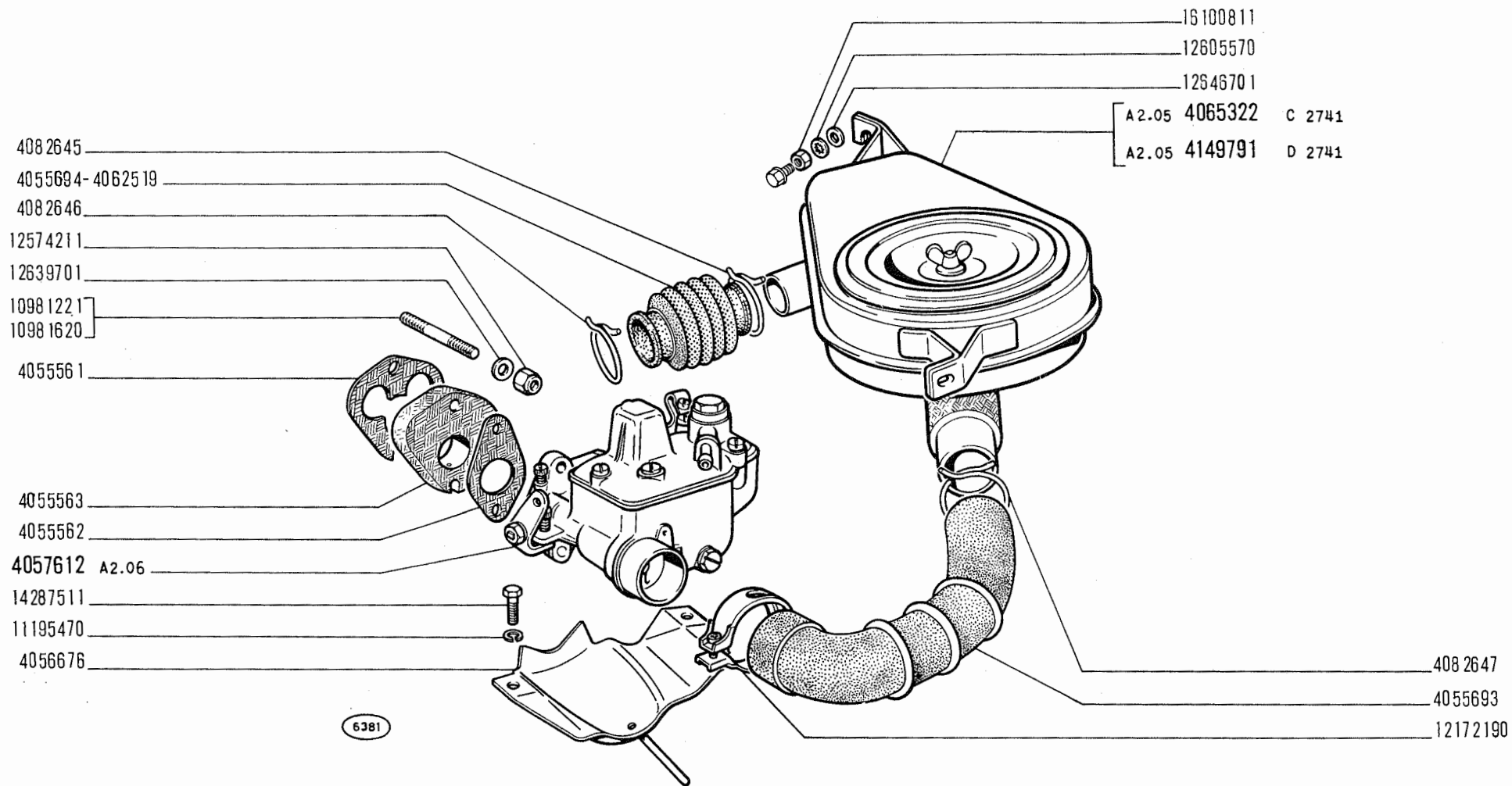

bianchina
panoramica

CARBURATORE E FILTRO ARIA

- Carburateur et filtre à air
- Vergaser und Luftfilter

- Carburetor and Air Cleaner
- Carburador y filtro de aire

A2.04

modif.	n. ordinaz.	quant.	Denominazione	Désignation	Benennung	Description	Denominaciones
	4055561	1	Guarnizione	Joint	Dichtung	Gasket	Junta
	4055562	1	Guarnizione	Joint	Dichtung	Gasket	Junta
	4055563	1	Isolante distanziale	Isolant	Isolierung	Insulator	Aislador
	4055693	1	Gomito	Coude	Kniestück	Elbow	Codo
	4055694	1	Manicotto	Manchon	Muffe	Sleeve	Manguito
	4056676	1	Riparo	Protection	Abdeckung	Protection	Defensa
	4057612	1	Carburatore compl.	Carburateur	Vergaser	Carburetor	Carburador
	4062519	1	Manicotto	Manchon	Muffe	Sleeve	Manguito
C 2741	4065322	1	Filtro aria compl.	Filtre à air	Luftfilter	Air cleaner	Filtro de aire
	4082645	1	Collare	Collier	Schelle	Collar	Abrazadera
	4082646	1	Collare	Collier	Schelle	Collar	Abrazadera
	4082647	1	Collare lato filtro	Collier	Schelle	Collar	Abrazadera
D 2741	4149791	1	Filtro aria compl.	Filtre à air	Luftfilter	Air cleaner	Filtro de aire
	10981221	1	Prigioniero corto	Goujon	Stiftschraube	Stud	Espárrago
	10981620	1	Prigioniero lungo	Goujon	Stiftschraube	Stud	Espárrago
	11195470	2	Rosetta elastica	Rondelle frein	Sicherungsring	Lockwasher	Arandela elástica
	12172190	1	Collare	Collier	Schelle	Collar	Abrazadera
	12574211	2	Dado	Écrou	Mutter	Nut	Tuerca
	12605570	2	Rosetta dentata	Rondelle frein	Sicherungsring	Lockwasher	Arandela dentada
	12639701	2	Rosetta piana	Rondelle	Scheibe	Washer	Arandela
	12646701	2	Rosetta piana	Rondelle	Scheibe	Washer	Arandela
	14287511	2	Vite	Vis	Schraube	Screw	Tornillo
	16100811	2	Dado	Écrou	Mutter	Nut	Tuerca

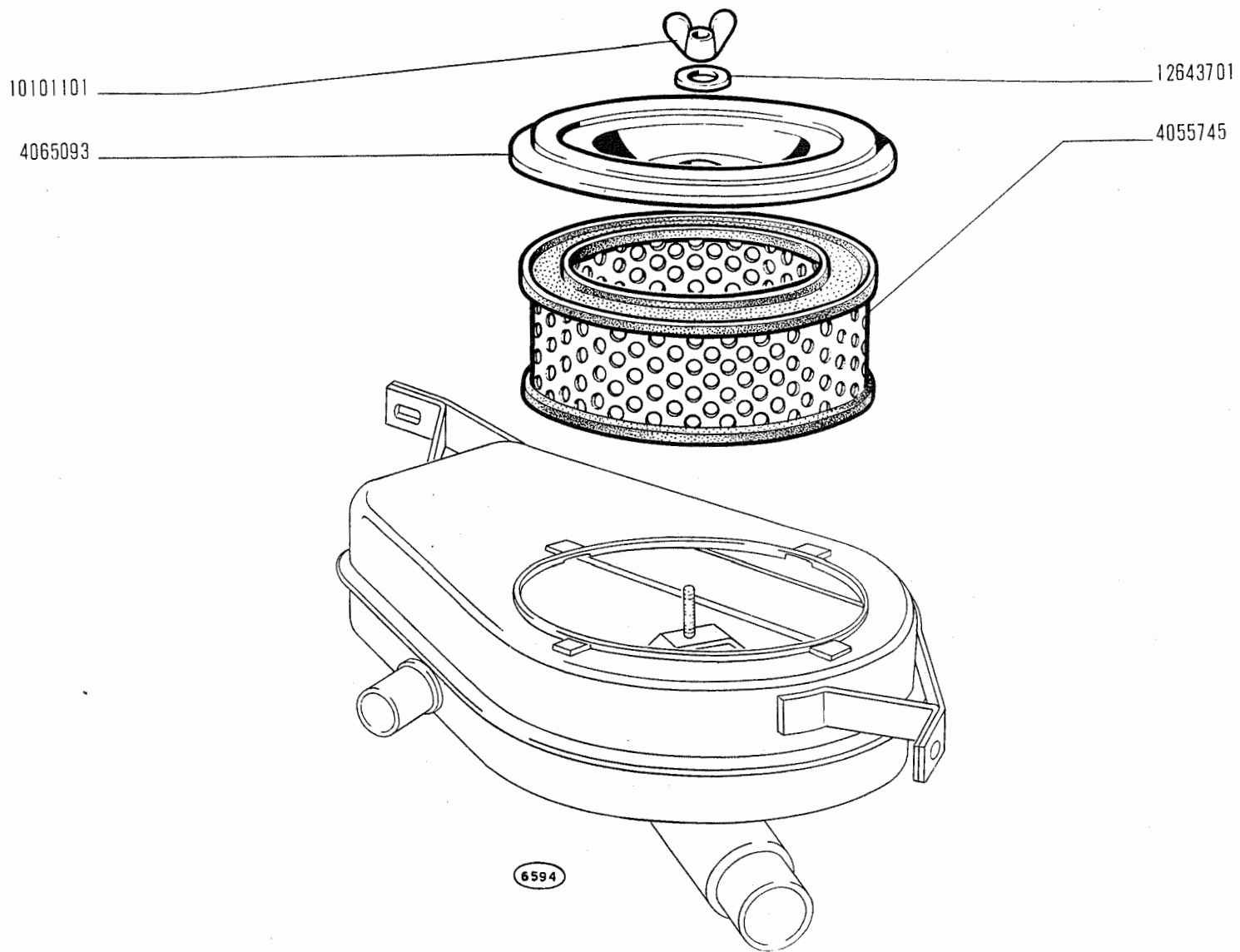

bianchina
panoramica
 e derivati

- Filtre à air
- Luftfilter

FILTRO ARIA 4065322 - 4149791

- Air Cleaner
- Filtro de aire

A2.05

modif.	n. ordinaz.	quant.	Denominazione	Désignation	Benennung	Description	Denominaciones
	4055745	1	Elemento filtrante	Élément filtrant	Filtereinsatz	Cartridge	Filtro
	4065093	1	Coperchio	Couvercle	Deckel	Cover	Tapa
	10101101	1	Dado	Écrou	Mutter	Nut	Tuerca
	12643701	1	Rosetta piana	Rondelle	Scheibe	Washer	Arandela

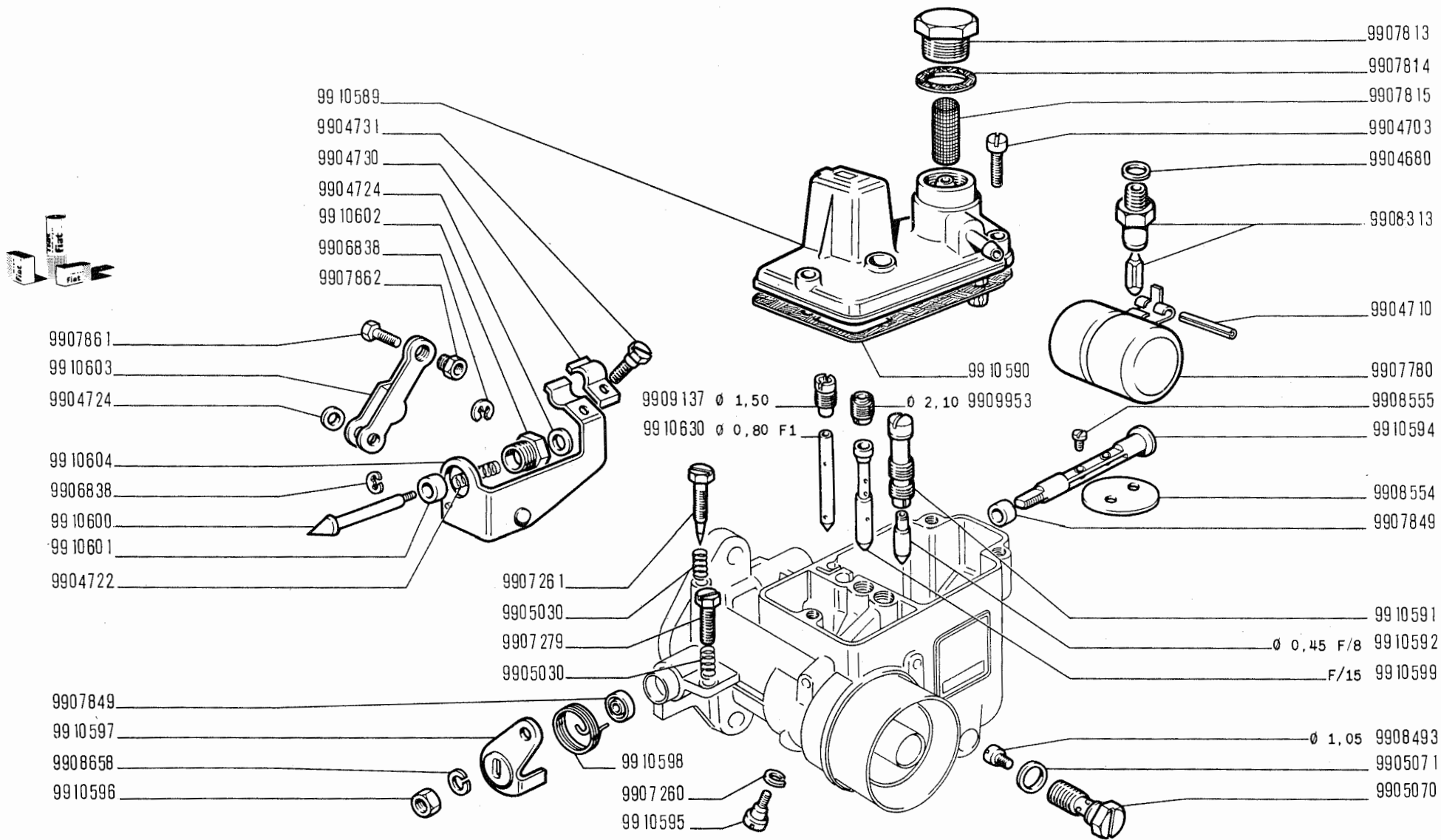

6414

blanchina
panoramica
 e derivati

● Carburateur
 ● Vergaser

CARBURATORE 4057612 (Weber)

● Carburetor
 ● Carburador

A2.06

modif.	n. ordinaz.	quant.	Denominazione	Désignation	Benennung	Description	Denominaciones
	9904680	1	Rosetta tenuta	Joint	Dichtring	Gasket	Junta
	9904703	3	Vite	Vis	Schraube	Screw	Tornillo
	9904710	1	Perno	Axe	Bolzen	Pin	Eje
	9904722	1	Molla	Ressort	Feder	Spring	Muelle
	9904724	2	Rosetta piana	Rondelle	Scheibe	Washer	Arandela
	9904730	1	Piastrina	Plaquette	Plättchen	Plate	Placa
	9904731	1	Vite	Vis	Schraube	Screw	Tornillo
	9905030	2	Molla	Ressort	Feder	Spring	Muelle
	9905070	1	Portagetto	Porte-gicleur	Düsenhalter	Jet holder	Portasurtidor
	9905071	1	Rosetta tenuta	Joint	Dichtring	Gasket	Junta
	9906838	2	Anello sicurezza	Arrêtoir	Sicherungsring	Lockring	Anillo de freno
	9907260	1	Rosetta sicurezza	Rondelle frein	Sicherungsring	Lockwasher	Arandela elástica
	9907261	1	Vite registro	Vis	Schraube	Screw	Tornillo
	9907279	1	Vite regolaz. minimo	Vis	Schraube	Screw	Tornillo
	9907780	1	Galleggiante	Flotteur	Schwimmer	Float	Flotador
	9907813	1	Tappo	Bouchon	Stopfen	Plug	Tapón
	9907814	1	Rosetta tenuta	Joint	Dichtring	Gasket	Junta
	9907815	1	Filtro	Filtre	Filter	Strainer	Filtro
	9907849	2	Anello tenuta	Joint	Dichtring	Seal	Junta
	9907861	1	Vite	Vis	Schraube	Screw	Tornillo
	9907862	1	Dado	Écrou	Mutter	Nut	Tuerca
	9908313	1	Valvola spillo \varnothing 1,25	Soupape	Ventil	Valve	Válvula
	9908493	1	Getto princ. 1,05	Gicleur	Düse	Jet	Surtidor
	9908554	1	Farfalla	Papillon	Drosselklappe	Throttle	Mariposa
	9908555	2	Vite	Vis	Schraube	Screw	Tornillo
	9908658	1	Rosetta sicurezza	Rondelle frein	Sicherungsring	Lockwasher	Arandela elástica
	9909137	1	Getto aria \varnothing 1,50	Gicleur	Düse	Jet	Surtidor
	9909953	1	Getto aria \varnothing 2,10	Gicleur	Düse	Jet	Surtidor
	9910589	1	Coperchio	Couvercle	Deckel	Cover	Tapa
	9910590	1	Guarnizione	Joint	Dichtung	Gasket	Junta
	9910591	1	Portagetto	Porte-gicleur	Düsenhalter	Jet holder	Portasurtidor
	9910592	1	Getto min. \varnothing 0,45 - f/8	Gicleur	Düse	Jet	Surtidor
	9910594	1	Alberino	Axe	Welle	Shaft	Eje
	9910595	1	Vite	Vis	Schraube	Screw	Tornillo

modif.	n. ordinaz.	quant.	Denominazione	Désignation	Benennung	Description	Denominaciones
	9910596	1	Dado	Écrou	Mutter	Nut	Tuerca
	9910597	1	Leva	Levier	Hebel	Lever	Palanca
	9910598	1	Molla	Ressort	Feder	Spring	Muelle
	9910599	1	Emulsionatore - f/15 -	Tube émulsion	Mischrohr	Emulsion tube	Emulsionador
	9910600	1	Valvola avv.	Soupape	Ventil	Valve	Válvula
	9910601	1	Boccola	Douille	Büchse	Bush	Casquillo
	9910602	1	Raccordo	Raccord	Stutzen	Connection	Racor
	9910603	1	Leva comando	Levier	Hebel	Lever	Palanca
	9910604	1	Supporto guaina	Support	Lager	Support	Soporte
	9910630	1	Getto avv. Ø 0,80 - f/1 -	Gicleur	Düse	Jet	Surtidor
	900812	S	Revisione completa	Révision complète	Überholung kpl.	Major overhaul	Revisión completa
	900821	S	Revisione normale	Révision normale	Überholung norm.	Standard overhaul	Revisión normal
	900829	S	Guarnizioni	Joints	Dichtungen	Gaskets	Juntas

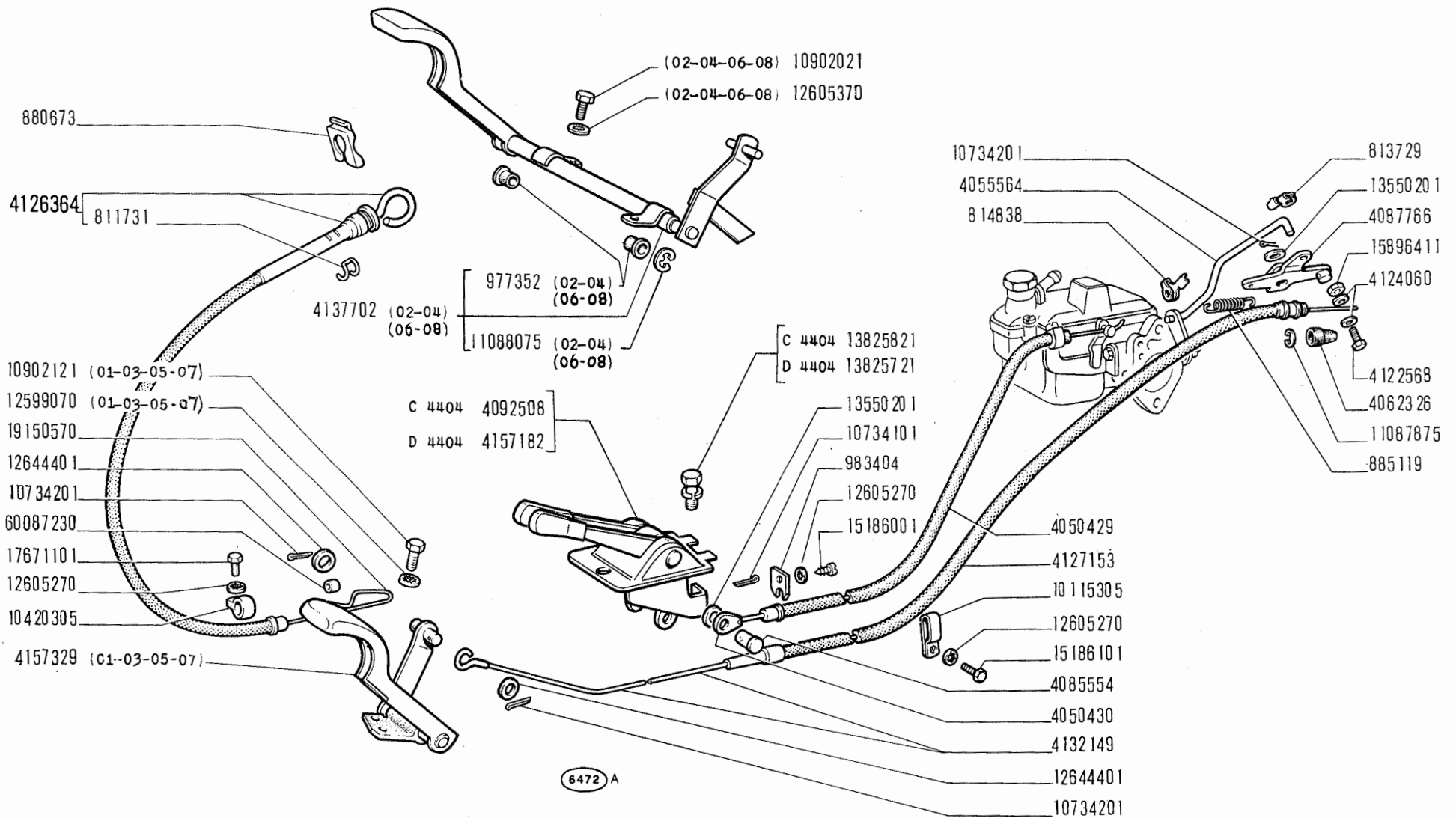

COMANDI ACCELERATORE E CARBURATORE

- Commandes d'accélérateur et de starter
- Gasregulierung

- Choke and Accelerator Control Linkage
- Mandos del acelerador y « starter »

modif.	n. ordinaz.	quant.	Denominazione	Désignation	Benennung	Description	Denominaciones
	811731	1	Molletta	Agrafe	Klemmstück	Clip	Sujetador
	813729	1	Fermaglio	Agrafe	Klemmstück	Clip	Sujetador
	814838	1	Fermaglio	Agrafe	Klemmstück	Clip	Sujetador
	880673	1	Piastrina elastica	Agrafe	Klemmstück	Clip	Sujetador
	885119	1	Molla richiamo	Ressort	Feder	Spring	Resorte
	977352	2	Boccola - 02 - 04 -	Douille	Büchse	Bush	Casquillo
	983404	1	Piastrina	Plaquette	Plättchen	Plate	Placa
	4050429	1	Guaina flessibile	Gaine	Hülle	Sheath	Funda
	4050430	1	Flessibile	Câble	Zugdraht	Wire	Bowden
	4055564	1	Tirante	Tirant	Stange	Rod	Varilla
	4062326	1	Cappuccio post.	Capuchon	Schutzkappe	Boot	Capuchón
	4085554	1	Perno	Axe	Bolzen	Pin	Pasador
C 4404	4087766	1	Leva rinvio	Levier	Hebel	Lever	Palanca
	4092508	1	Supporto con leve	Support	Lager	Support	Soporte
	4122568	1	Vite con foro	Vis	Schraube	Screw	Tornillo
	4124060	2	Rosetta piana	Rondelle	Scheibe	Washer	Arandela
	4126364	1	Comando a mano compl.	Commande à main	Handzug	Hand control	Mando manual
	4127153	1	Guaina flessibile	Gaine	Hülle	Sheath	Funda
	4132149	1	Flessibile	Câble	Zugdraht	Wire	Bowden
	4137702	1	Pedale compl. - 02 - 04 - 06 - 08 -	Pédale	Fusshebel	Pedal	Pedal
D 4404	4157182	1	Supporto con leve	Support	Lager	Support	Soporte
	4157329	1	Pedale - 01 - 03 - 05 - 07 -	Pédale	Fusshebel	Pedal	Pedal
	10115305	1	Staffetta	Collier	Schelle	Retainer	Abrazadera
	10420305	1	Staffetta	Collier	Schelle	Retainer	Abrazadera
	10734101	1	Copiglia spaccata	Goupille	Splint	Pin	Pasador abierto
	10734201	3	Copiglia spaccata	Goupille	Splint	Pin	Pasador abierto
	10902021	2	Vite - 02 - 04 - 06 - 08 -	Vis	Schraube	Screw	Tornillo
	10902121	2	Vite - 01 - 03 - 05 - 07 -	Vis	Schraube	Screw	Tornillo
	11087875	1	Anello sicurezza	Arrêtoir	Sicherungsring	Lockring	Anillo de freno
	11088075	1	Anello sicurezza - 02 - 04 - 06 - 08 -	Arrêtoir	Sicherungsring	Lockring	Anillo de freno
	12599070	2	Rosetta elastica - 01 - 03 - 05 - 07 -	Rondelle frein	Sicherungsring	Lockwasher	Arandela elástica
	12605270	3	Rosetta dentata	Rondelle frein	Sicherungsring	Lockwasher	Arandela dentada
	12605370	2	Rosetta dentata - 02 - 04 - 06 - 08 -	Rondelle frein	Sicherungsring	Lockwasher	Arandela dentada
	12644401	2	Rosetta piana	Rondelle	Scheibe	Washer	Arandela

modif.	n. ordinaz.	quant.	Denominazione	Désignation	Benennung	Description	Denominaciones
	13550201	2	Rosetta piana	Rondelle	Scheibe	Washer	Arandela
D 4404	13825721	1	Vite	Vis	Schraube	Screw	Tornillo
C 4404	13825821	2	Vite	Vis	Schraube	Screw	Tornillo
	15186001	1	Vite autofilettante	Vis	Blechschaube	Screw (self-threading)	Tornillo
	15186101	1	Vite autofilettante	Vis	Blechschaube	Screw (self-threading)	Tornillo
	15896411	1	Dado	Écrou	Mutter	Nut	Tuerca
	17671101	1	Vite	Vis	Schraube	Screw	Tornillo
	19150570	m	Trasmissione int.	Transmission	Bowdenzug	Flex/shaft	Árbol flexible
	60087230	1	Tubetto distanziale	Entretoise	Abstandstück	Spacer	Separador

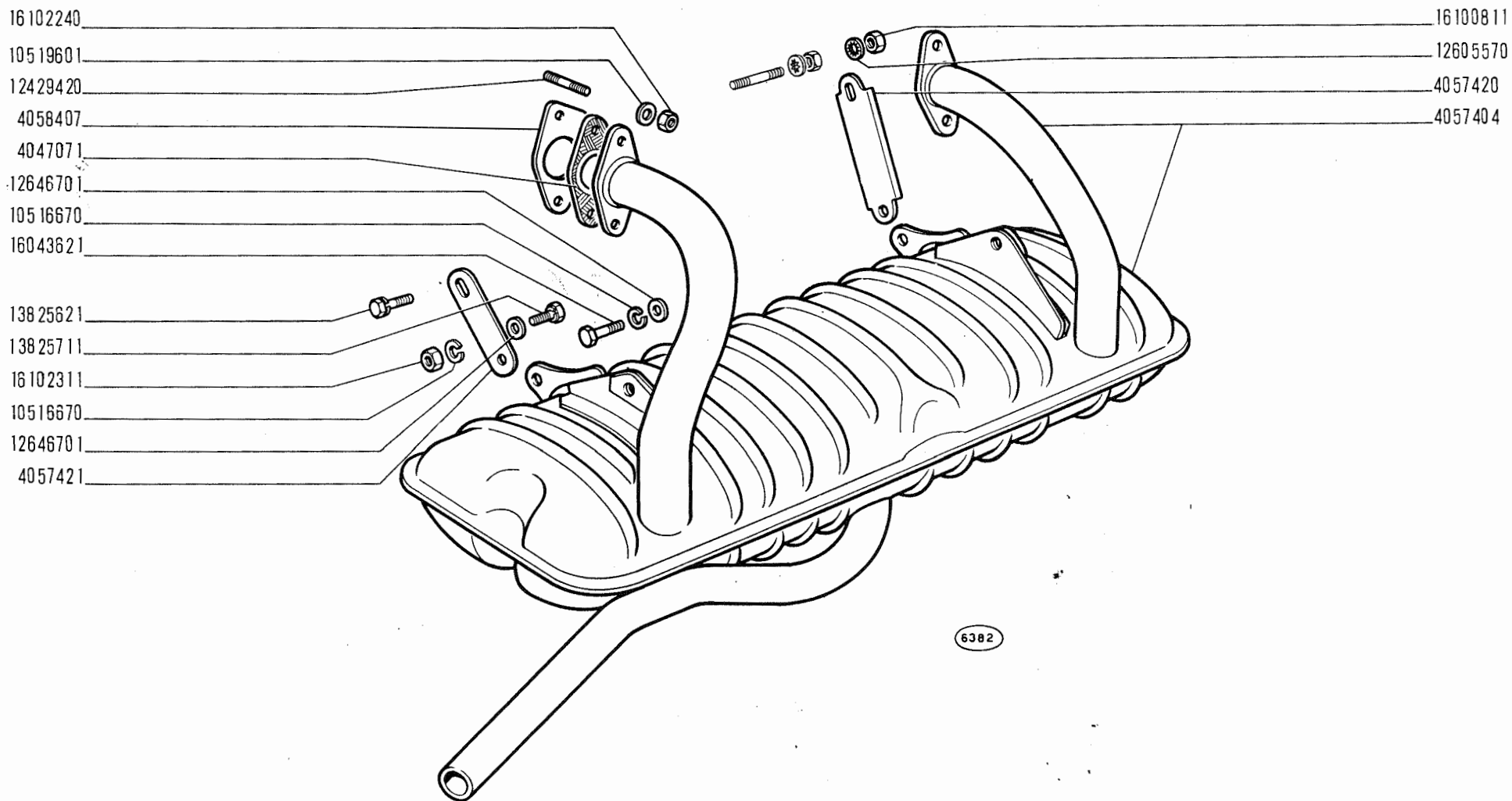

TUBAZIONE DI SCARICO

- Canalisation d'échappement
- Auspuffleitung

- Exhaust Pipe
- Tuberla de escape

modif.	n. ordinaz.	quant.	Denominazione	Désignation	Benennung	Description	Denominaciones
	4047071	2	Guarnizione	Joint	Dichtung	Gasket	Junta
	4057404	1	Silenziatore	Silencieux	Auspufftopf	Silencer	Silenciador
	4057420	1	Piastrina	Plaquette	Drucklasche	Strut	Placa
	4057421	1	Piastrina	Plaquette	Drucklasche	Strut	Placa
	4058407	2	Guarnizione	Joint	Dichtung	Gasket	Junta
	10516670	4	Rosetta elastica	Rondelle frein	Sicherungsring	Lockwasher	Arandela elástica
	10519601	4	Rosetta piana	Rondelle	Scheibe	Washer	Arandela
	12429420	4	Prigioniero	Goujon	Stiftschraube	Stud	Espárrago
	12605570	1	Rosetta dentata	Rondelle frein	Sicherungsring	Lockwasher	Arandela dentada
	12646701	4	Rosetta piana	Rondelle	Scheibe	Washer	Arandela
	13825621	1	Vite	Vis	Schraube	Screw	Tornillo
	13825711	2	Vite	Vis	Schraube	Screw	Tornillo
	16043621	2	Vite	Vis	Schraube	Screw	Tornillo
	16100811	1	Dado	Écrou	Mutter	Nut	Tuerca
	16102240	4	Dado	Écrou	Mutter	Nut	Tuerca
	16102311	2	Dado	Écrou	Mutter	Nut	Tuerca

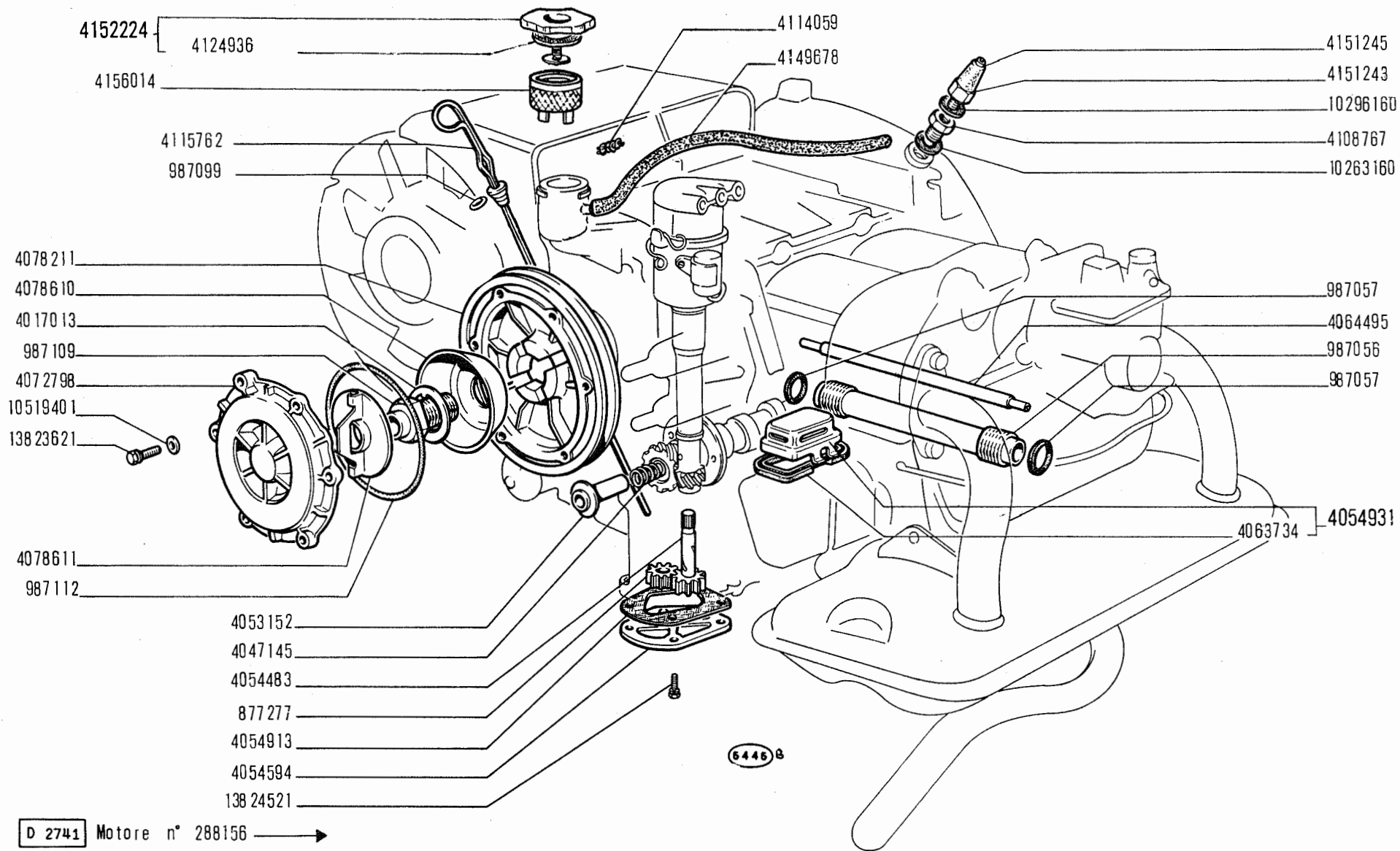

bianchina
panoramica
e derivati

● Graissage
● Schmierung

LUBRIFICAZIONE

● Lubrication System
● Sistema de engrase

A3.01

modif.	n. ordinaz.	quant.	Denominazione	Désignation	Benennung	Description	Denominaciones
	877277	1	Ingranaggio condotto	Pignon	Zahnrad	Gear	Piñón
	987056	1	Astuccio	Etui	Hülse	Casing	Tube
	987057	2	Anello tenuta	Joint	Dichtring	Seal	Junta
	987099	1	Anello tenuta	Joint	Dichtring	Seal	Junta
	987109	1	Vite	Vis	Schraube	Screw	Tornillo
	987112	1	Anello tenuta	Joint	Dichtring	Seal	Junta
	4017013	1	Piastrina sicurezza	Plaquette frein	Sicherungsblech	Lockplate	Arandela de freno
	4047145	1	Molla	Ressort	Feder	Spring	Muelle
	4053152	1	Valvola	Soupape	Ventil	Valve	Válvula
	4054483	1	Ingranaggio conduttore	Pignon	Zahnrad	Gear	Piñón
	4054594	1	Coperchio	Couvercle	Deckel	Cover	Tapa
	4054913	1	Guarnizione	Joint	Dichtung	Gasket	Junta
	4054931	1	Filtro compl.	Filtre	Filter	Intake filter	Filtro
	4063734	1	Guarnizione	Joint	Dichtung	Gasket	Junta
	4064495	1	Tubo	Tuyau	Rohr	Pipe	Tube
	4072798	1	Coperchio	Couvercle	Deckel	Cover	Tapa
	4078211	1	Centrifugatore olio	Centrifugeur	Ölschleuderring	Centrifugal filter	Centrifugador
	4078610	1	Deflettore	Défecteur	Leitblech	Slinger	Deflector
	4078611	1	Anello	Bague	Ring	Ring	Anillo
	4108767	1	Raccordo	Raccord	Stutzen	Connection	Racor
	4114059	1	Spegnifiamma	Coupe-flamme	Flammenlöscher	Flame trap	Apagallamas
	4115762	1	Asta livello olio	Jauge	Ölmesstab	Level rod	Varilla de nivel
	4124936	1	Guarnizione	Joint	Dichtring	Seal	Junta
	4149678	1	Manicotto	Manchon	Schlauch	Hose	Manguito
	4151243	1	Trasmettitore	Contacteur	Kontaktgeber	Sending unit	Contacteur
	4151245	1	Cappuccio	Capuchon	Schutzkappe	Boot	Capucha
	4152224	1	Tappo compl.	Bouchon	Schraubdeckel	Cap	Tapón
	4156014	1	Reticella	Crépine	Sieb	Strainer	Filtro
	10263160	1	Guarnizione	Joint	Dichtring	Gasket	Junta
	10296160	1	Guarnizione	Joint	Dichtring	Gasket	Junta
	10519401	6	Rosetta piana	Rondelle	Scheibe	Washer	Arandela
	13823621	6	Vite	Vis	Schraube	Screw	Tornillo
	13824521	4	Vite	Vis	Schraube	Screw	Tornillo

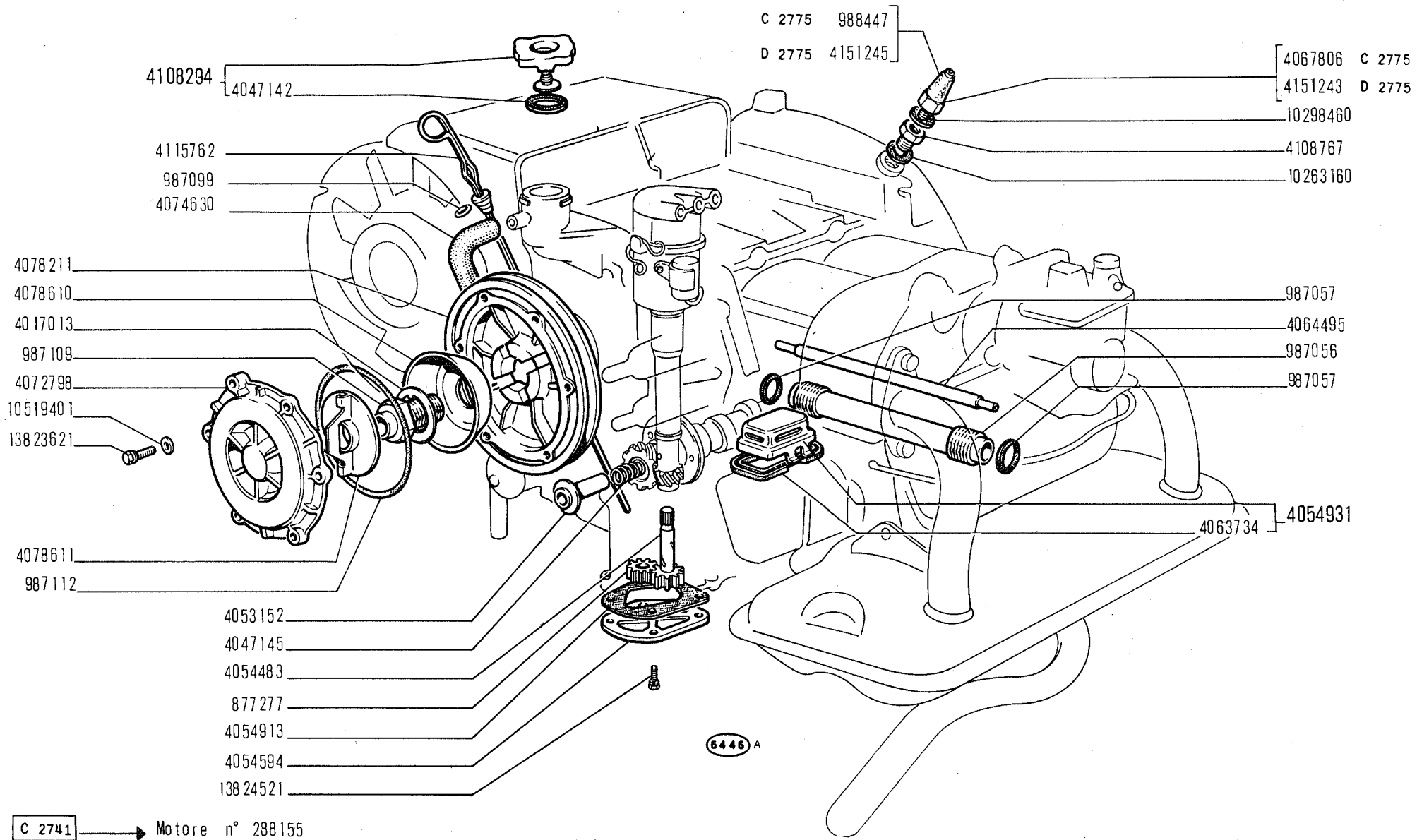

blanchina
panoramica

● Graissage
● Schmierung

LUBRIFICAZIONE

● Lubrication System
● Sistema de engrase

A3.01/1

modif.	n. ordinaz.	quant.	Denominazione	Désignation	Benennung	Description	Denominaciones
	877277	1	Ingranaggio condotto	Pignon	Zahnrad	Gear	Piñón
	987056	1	Astuccio	Étui	Hülse	Casing	Tube
	987057	2	Anello tenuta	Joint	Dichtring	Seal	Junta
	987099	1	Anello tenuta	Joint	Dichtring	Seal	Junta
	987109	1	Vite	Vis	Schraube	Screw	Tornillo
	987112	1	Anello tenuta	Joint	Dichtring	Seal	Junta
C 2775	988447	1	Cappuccio	Capuchon	Schutzkappe	Boot	Capucha
	4017013	1	Piastrina sicurezza	Plaquette frein	Sicherungsblech	Lockplate	Placa de freno
	4047142	1	Anello tenuta	Joint	Dichtring	Seal	Junta
	4047145	1	Molla	Ressort	Feder	Spring	Muelle
	4053152	1	Valvola	Soupape	Ventil	Valve	Válvula
	4054483	1	Ingranaggio conduttore	Pignon	Zahnrad	Gear	Pinón
	4054594	1	Coperchio	Couvercle	Deckel	Cover	Tapa
	4054913	1	Guarnizione	Joint	Dichtung	Gasket	Junta
	4054931	1	Filtro compl.	Filtre à huile	Ölfilter	Intake filter	Filtro de aceite
	4063734	1	Guarnizione	Joint	Dichtung	Gasket	Junta
	4064495	1	Tubo	Tuyau	Rohr	Pipe	Tubo
C 2775	4067806	1	Trasmettitore	Contacteur	Kontaktgeber	Sending unit	Contactador
	4072798	1	Coperchio	Couvercle	Deckel	Cover	Tapa
	4074630	1	Manicotto	Manchon	Muffe	Sleeve	Manguito
	4078211	1	Centrifugatore olio	Centrifugeur	Ölschleuderring	Centrifugal filter	Centrifugador
	4078610	1	Deflettore	Défecteur	Leitblech	Slinger	Deflector
	4078611	1	Anello	Bague	Ring	Ring	Anillo
	4108294	1	Tappo compl.	Bouchon	Schraubdeckel	Cap	Tapón
	4108767	1	Raccordo	Raccord	Stutzen	Connection	Racor
	4115762	1	Asta livello olio	Jauge	Messtab	Level rod	Varilla de nivel
D 2775	4151243	1	Trasmettitore	Contacteur	Kontaktgeber	Sending unit	Contactador
D 2775	4151245	1	Cappuccio	Capuchon	Schutzkappe	Boot	Capucha
	10263160	1	Guarnizione	Joint	Dichtring	Gasket	Junta
	10298460	1	Guarnizione	Joint	Dichtring	Gasket	Junta
	10519401	6	Rosetta piana	Rondelle	Scheibe	Washer	Arandela
	13823621	6	Vite	Vis	Schraube	Screw	Tornillo
	13824521	4	Vite	Vis	Schraube	Screw	Tornillo

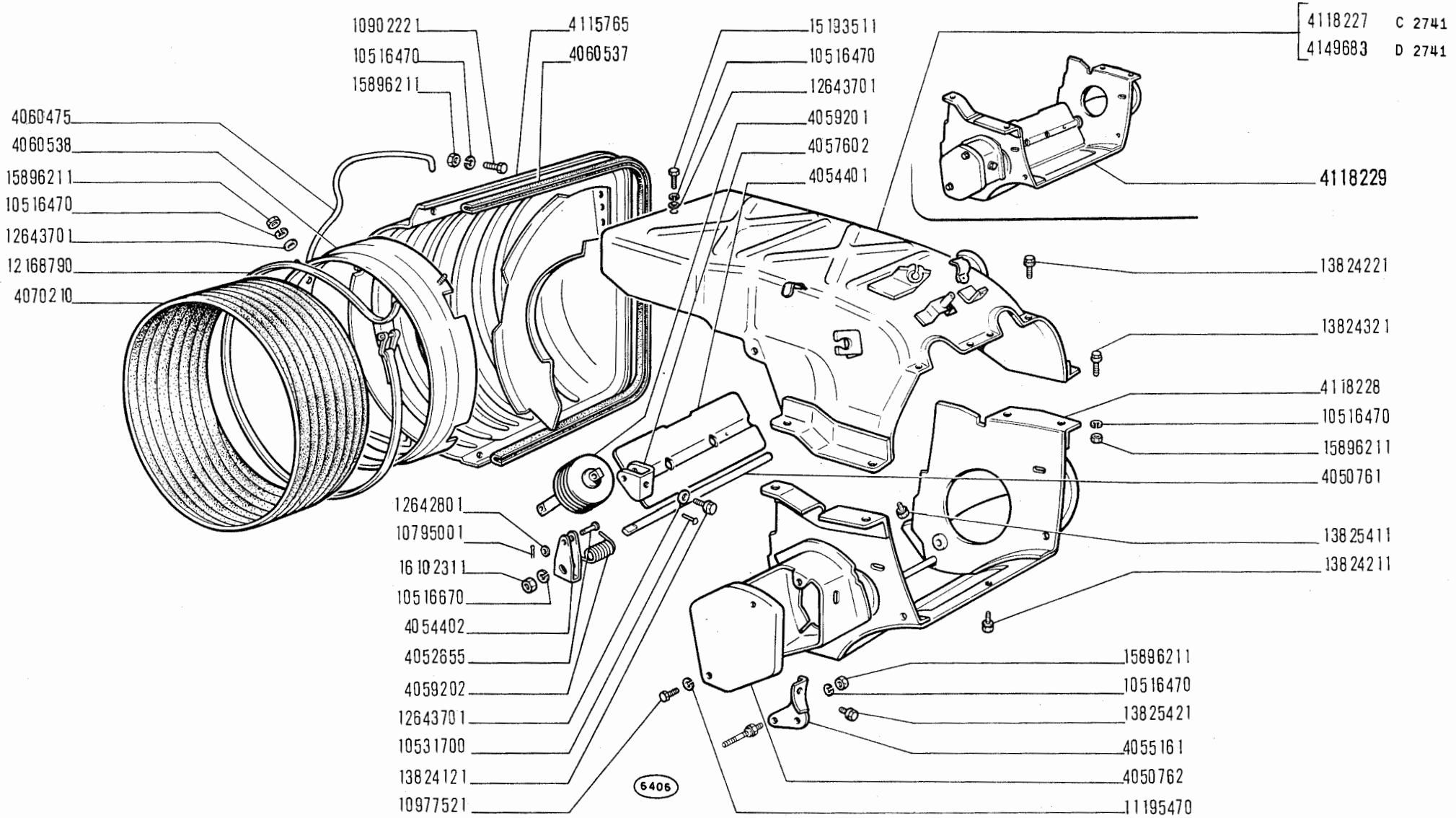

blanchina
panoramica

PRESE ARIA E CONVOGLIATORE

- Prises d'air et convoyeur
- Lufteintritt und Kühlluftführung

- Air Intakes and Conveyor
- Bocas de aire y canalizador

A4.07

modif.	n. ordinaz.	quant.	Denominazione	Désignation	Benennung	Description	Denominaciones
	4050761	1	Perno	Axe	Bolzen	Pin	Eje
	4050762	1	Coperchio	Couvercle	Deckel	Cover	Tapa
	4052655	2	Perno	Axe	Bolzen	Pin	Pasador
	4054401	1	Farfalla	Papillon	Drosselklappe	Throttle	Mariposa
	4054402	1	Leva	Levier	Hebel	Lever	Palanca
	4055161	1	Staffa	Étrier	Halter	Bracket	Soporte
	4057602	1	Supporto sup.	Support	Lager	Support	Soporte
	4059201	1	Termostato	Thermostat	Thermostat	Thermostat	Termostato
	4059202	1	Molla richiamo	Ressort	Feder	Spring	Muelle
	4060475	1	Staffa	Collier	Schelle	Clamp	Collar
	4060537	1	Guarnizione	Caoutchouc	Profilgummi	Weatherstrip	Goma
	4060538	1	Convogliatore lat.	Convoyeur	Leitblech	Conveyor	Canalizador
	4070210	1	Tubo flessibile	Tuyau	Schlauch	Hose	Tubo flexible
	4115765	1	Rivestimento	Revêtement	Verkleidung	Panel	Panel
C 2741	4118227	1	Convogliatore sup.	Convoyeur	Leitblech	Conveyor	Canalizador
	4118228	1	Convogliatore inf.	Convoyeur	Leitblech	Conveyor	Canalizador
	4118229	1	Convogliatore inf. compl.	Convoyeur	Leitblech	Conveyor	Canalizador
D 2741	4149683	1	Convogliatore sup	Convoyeur	Leitblech	Conveyor	Canalizador
	10516470	16	Rosetta elastica	Rondelle	Sicherungsring	Lockwasher	Arandela elástica
	10516670	1	Rosetta elastica	Rondelle	Sicherungsring	Lockwasher	Arandela elástica
	10531700	2	Ribattino	Rivet	Niet	Rivet	Remache
	10795001	2	Copiglia	Goupille	Splint	Pin	Pasador abierto
	10902221	2	Vite	Vis	Schraube	Screw	Tornillo
	10977521	2	Vite	Vis	Schraube	Screw	Tornillo
	11195470	2	Rosetta elastica	Rondelle	Sicherungsring	Lockwasher	Arandela elástica
	12168790	1	Collare	Collier	Schelle	Collar	Abrazadera
	12642801	2	Rosetta piana	Rondelle	Scheibe	Washer	Arandela
	12643701	9	Rosetta piana	Rondelle	Scheibe	Washer	Arandela
	13824121	1	Vite	Vis	Schraube	Screw	Tornillo
	13824211	1	Vite	Vis	Schraube	Screw	Tornillo
	13824221	4	Vite	Vis	Schraube	Screw	Tornillo
	13824321	5	Vite	Vis	Schraube	Screw	Tornillo
	13825411	1	Vite	Vis	Schraube	Screw	Tornillo
	13825421	1	Vite	Vis	Schraube	Screw	Tornillo
	15193511	5	Vite	Vis	Schraube	Screw	Tornillo
	15896211	11	Dado	Écrou	Mutter	Nut	Tuerca
	16102311	1	Dado	Écrou	Mutter	Nut	Tuerca

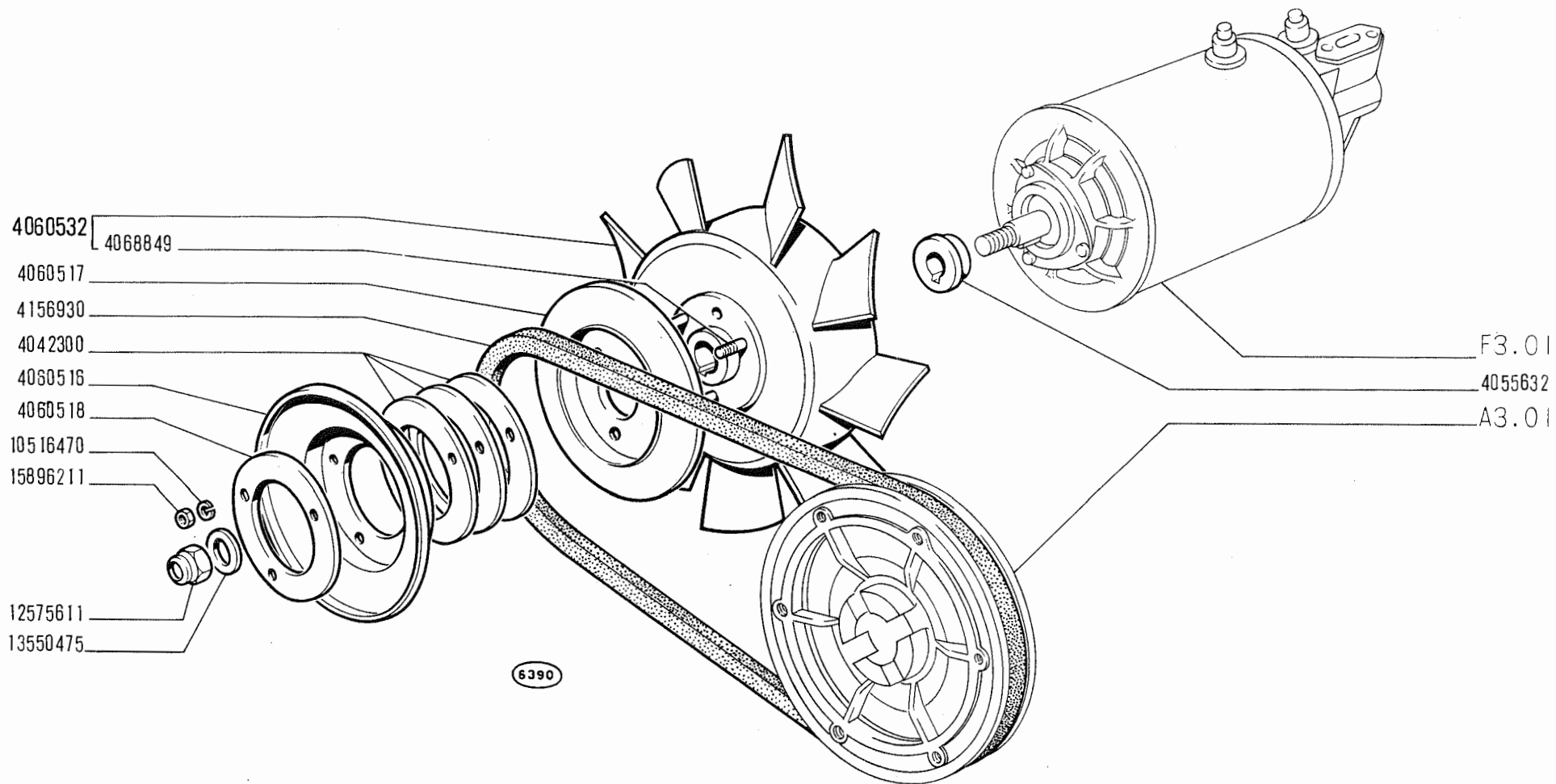

bianchina
panoramica
 e derivati

- Ventilateur
- Lüfter

VENTILATORE

- Fan
- Ventilador

A4.09

modif.	n. ordinaz.	quant.	Denominazione	Désignation	Benennung	Description	Denominaciones
	4042300	3	Anello registro	Rondelle	Scheibe	Washer	Arandela
	4055632	1	Distanziale	Entretoise	Abstandstück	Spacer	Separador
	4060516	1	Semipuleggia ant.	Joue de poulie	Scheibenhälfte	Half-pulley	Cara de polea
	4060517	1	Semipuleggia post.	Joue de poulie	Scheibenhälfte	Half-pulley	Cara de polea
	4060518	1	Rondella	Rondelle	Scheibe	Washer	Arandela
	4060532	1	Ventilatore compl.	Ventilateur	Lüfter	Fan	Ventilador
	4068849	3	Prigioniero	Goujon	Stiftschraube	Stud	Espárrago
	4156930	1	Cinghia	Courroie	Riemen	Belt	Correa
	10516470	3	Rosetta elastica	Rondelle	Sicherungsring	Lockwasher	Arandela elástica
	12575611	1	Dado	Écrou	Mutter	Nut	Tuerca
	13550475	1	Rosetta piana	Rondelle	Scheibe	Washer	Arandela
	15896211	3	Dado	Écrou	Mutter	Nut	Tuerca

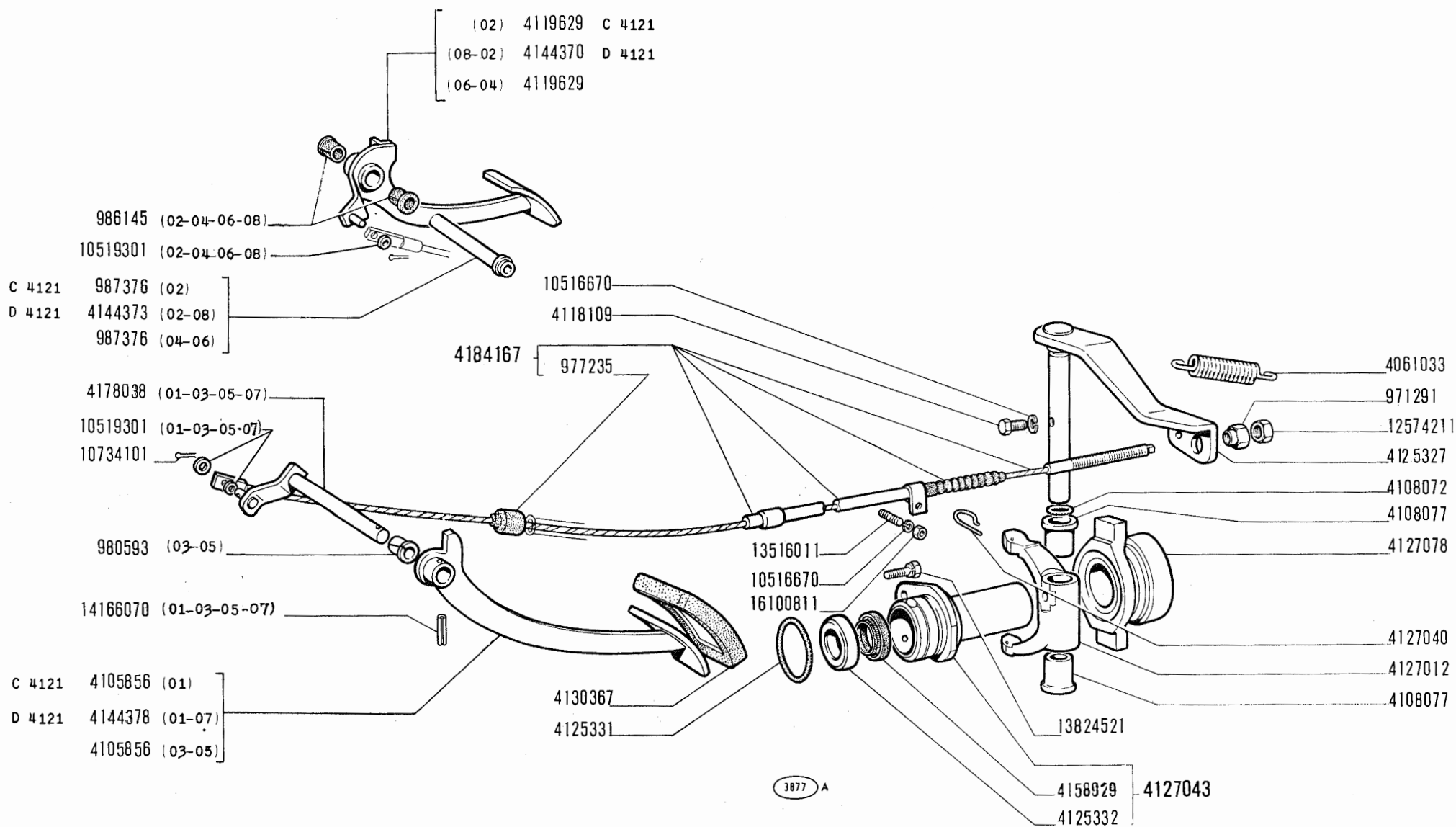

blanchina
panoramica
 a derivati

COMANDO DISINNESTO FRIZIONE

- *Commande de débrayage*
- *Kupplungsbetätigung*

- *Clutch Release Control-*
- *Sistema de embrague*

B1.01

modif.	n. ordinaz.	quant.	Denominazione	Désignation	Benennung	Description	Denominaciones
	971291	1	Testa registro	Écrou	Mutter	Nut	Tuerca
	977235	1	Cuffia	Capuchon	Manschette	Boot	Capuchón
	980593	2	Boccola - 03 - 05 -	Douille	Büchse	Bush	Casquillo
	986145	2	Boccola - 02 - 04 - 06 - 08 -	Douille	Büchse	Bush	Casquillo
C 4121	987376	1	Perno - 0,2 -	Axe	Bolzen	Pin	Eje
	987376	1	Perno - 04 - 06 -	Axe	Bolzen	Pin	Eje
	4061033	1	Molla richiamo	Ressort	Feder	Spring	Muelle
	4105856	1	Pedale - 03 - 05 -	Pédale	Fusshebel	Pedal	Pedal
C 4121	4105856	1	Pedale - 01 -	Pédale	Fusshebel	Pedal	Pedal
	4108072	1	Anello tenuta	Joint	Dichtring	Seal	Junta
	4108077	2	Boccola	Douille	Büchse	Bush	Casquillo
	4118109	1	Vite	Vis	Schraube	Screw	Tornillo
C 4121	4119629	1	Pedale - 02 -	Pédale	Fusshebel	Pedal	Pedal
	4119629	1	Pedale - 04 - 06 -	Pédale	Fusshebel	Pedal	Pedal
	4125327	1	Albero post.	Arbre	Welle	Shaft	Árbol
	4125331	1	Anello tenuta	Joint	Dichtring	Seal	Junta
	4125332	1	Boccola	Douille	Büchse	Bush	Casquillo
	4127012	1	Forcella	Fourche	Gabel	Fork	Horquilla
	4127040	2	Molletta	Agrafe	Klemmstück	Clip	Sujetador
	4127043	1	Supporto compl.	Support	Lager	Support	Soporte
	4127078	1	Cuscinetto con manicotto	Roulement	Lager	Bearing	Rodamiento
	4130367	1	Copripedale gomma	Caoutchouc	Fusshebelüberzug	Pad	Forro
D 4121	4144370	1	Pedale - 02 - 08 -	Pédale	Fusshebel	Pedal	Pedal
D 4121	4144373	1	Perno - 02 - 08 -	Axe	Bolzen	Pin	Eje
D 4121	4144378	1	Pedale - 01 - 07 -	Pédale	Fusshebel	Pedal	Pedal
	4158929	1	Guarnizione	Joint	Dichtring	Seal	Junta
	4178038	1	Alberino - 01 - 03 - 05 - 07 -	Arbre	Welle	Shaft	Árbol
	4184167	1	Trasmissione fless. compl.	Transmission	Bowdenzug	Flex/shaft	Árbol flexible
	10516670	2	Rosetta elastica	Rondelle	Sicherungsring	Lockwasher	Arandela elástica
	10519301	2	Rosetta piana - 01 - 03 - 05 - 07 -	Rondelle	Scheibe	Washer	Arandela
	10519301	1	Rosetta piana - 02 - 04 - 06 - 08 -	Rondelle	Scheibe	Washer	Arandela
	10734101	1	Copiglia spaccata	Goupille	Splint	Pin	Pasador abierto
	12574211	1	Dado	Écrou	Mutter	Nut	Tuerca
	13516011	1	Prigioniero	Goujon	Stiftschraube	Stud	Espárrago
	13824521	1	Vite	Vis	Schraube	Screw	Tornillo
	14166070	1	Spina elastica - 01 - 03 - 05 - 07 -	Goupille	Stift	Pin	Pasador
	16100811	1	Dado	Écrou	Mutter	Nut	Tuerca

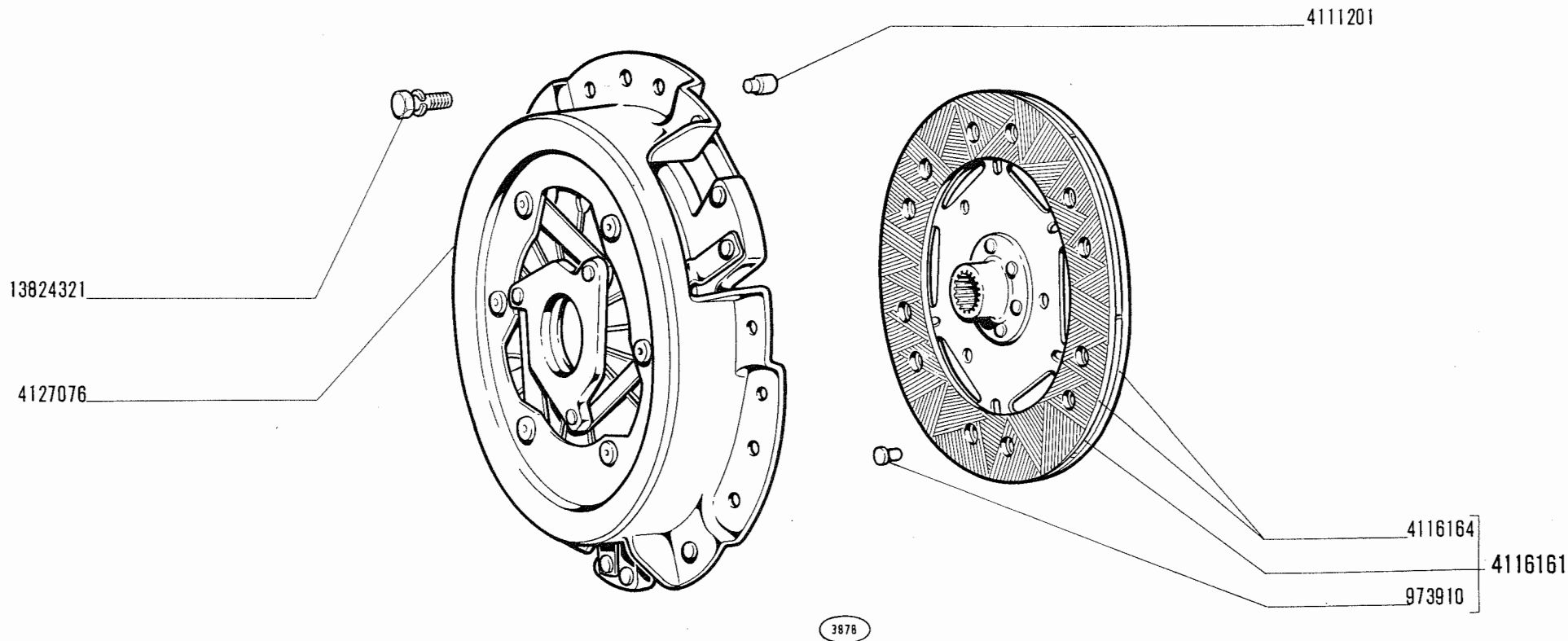

modif.	n. ordinaz.	quant.	Denominazione	Désignation	Benennung	Description	Denominaciones
	973910	12	Ribattino	Rivet	Niet	Rivet	Remache
	4111201	2	Grano	Ergot	Passtift	Dowel	Pitón
	4116161	1	Disco condotto compl.	Disque entraîné	Kupplungsscheibe	Driven plate	Disco de embrague
	4116164	2	Anello frizione	Garniture	Kupplungsbelag	Facing	Forro
	4127076	1	Coppa frizione	Carter	Gehäuse	Clutch housing	Campana
	13824321	6	Vite	Vis	Schraube	Screw	Tornillo

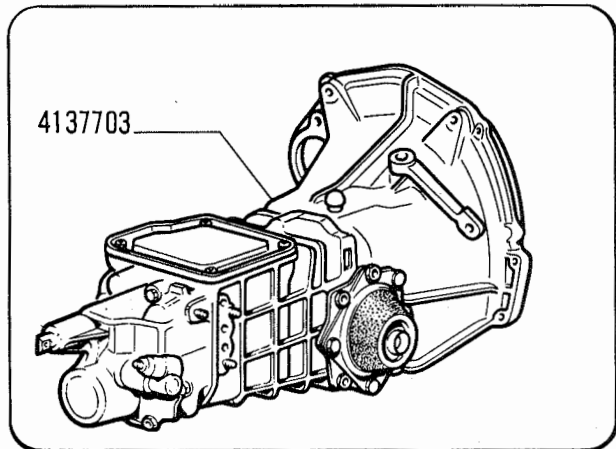

C 2854 970679
D 2854 4162065

970812
970815
10516470
15896211

C 2854 10358611
D 2854 13303611

6387 A

4016311
874690

10519601
10516670
16100811
14323613
874690
4119727
4014771
13824321

997807
4126136
12430230
11195470
10977521
4050536

12606970 D 2854

883175
11500210
970814

4111915
12164711
10516870
13454510
13454310

970813
15896211
10516470
4012477

blanchina
panoramica
e derivati

CAMBIO E DIFFERENZIALE, SCATOLA E COPERCHI

- Boîte et différentiel, carter et couvercles
- Wechsel- und Ausgleichgetriebe, Gehäuse und Deckel
- Transmission-and-Differential Unit, Casing and Covers
- Cambio y diferencial, caja y tapas

B2.01

modif.	n. ordinaz.	quant.	Denominazione	Désignation	Benennung	Description	Denominaciones
C 2854	874690	4	Grano	Ergot	Passtift	Dowel	Pitón
	883175	1	Tappo scarico	Bouchon	Stopfen	Plug	Tapón
	970679	1	Piastra ant.	Plaque	Platte	Plate	Placa
	970812	1	Guarnizione	Joint	Dichtung	Gasket	Junta
	970813	1	Coperchio	Couvercle	Deckel	Cover	Tapa
	970814	1	Guarnizione	Joint	Dichtung	Gasket	Junta
	970815	5	Prigioniero	Goujon	Stiftschraube	Stud	Espárrago
	997807	1	Prigioniero corto	Goujon	Stiftschraube	Stud	Espárrago
	4012477	1	Rosetta piana	Rondelle	Scheibe	Washer	Arandela
	4014771	1	Coperchio sup.	Couvercle	Deckel	Cover	Tapa
	4016311	1	Coperchio ant. compl.	Couvercle	Deckel	Cover	Tapa
	4050536	1	Coperchio	Couvercle	Deckel	Cover	Tapa
	4111915	1	Scatola compl.	Carter	Gehäuse	Case	Caja
	4119727	1	Guarnizione	Joint	Dichtung	Gasket	Junta
	4136136	1	Sfiatatoio	Reniflard	Entlüftungsrohr	Vent	Respiradero
4137703	1	Cambio e differenziale compl.	Boîte et différentiel	Wechsel- und Ausgleich- getriebe	Transmission and differen- tial unit	Caja de cambios y dife- rencial	
D 2854	4162065	1	Piastra ant.	Plaque	Platte	Plate	Placa
C 2854	10358611	2	Vite	Vis	Schraube	Screw	Tornillo
	10516470	6	Rosetta elastica	Rondelle	Sicherungsring	Lockwasher	Arandela elástica
	10516670	4	Rosetta elastica	Rondelle	Sicherungsring	Lockwasher	Arandela elástica
	10516870	6	Rosetta elastica	Rondelle	Sicherungsring	Lockwasher	Arandela elástica
	10519601	4	Rosetta piana	Rondelle	Scheibe	Washer	Arandela
	10977521	3	Vite	Vis	Schraube	Screw	Tornillo
	11195470	3	Rosetta elastica	Rondelle	Sicherungsring	Lockwasher	Arandela elástica
	11500210	1	Prigioniero	Goujon	Stiftschraube	Stud	Espárrago
	12164711	6	Dado	Écrou	Mutter	Nut	Tuerca
D 2854	12430230	3	Prigioniero lungo	Goujon	Stiftschraube	Stud	Espárrago
	12606970	2	Rosetta	Rondelle	Scheibe	Washer	Arandela
D 2854	13303611	2	Vite	Vis	Schraube	Screw	Tornillo
	13454310	2	Prigioniero inf. e sup.	Goujon	Stiftschraube	Stud	Espárrago
	13454510	4	Prigioniero centr.	Goujon	Stiftschraube	Stud	Espárrago
	13824321	4	Vite	Vis	Schraube	Screw	Tornillo
	14323613	1	Tappo introduzione	Bouchon	Stopfen	Plug	Tapón
	15896211	6	Dado	Écrou	Mutter	Nut	Tuerca
	16100811	4	Dado	Écrou	Mutter	Nut	Tuerca

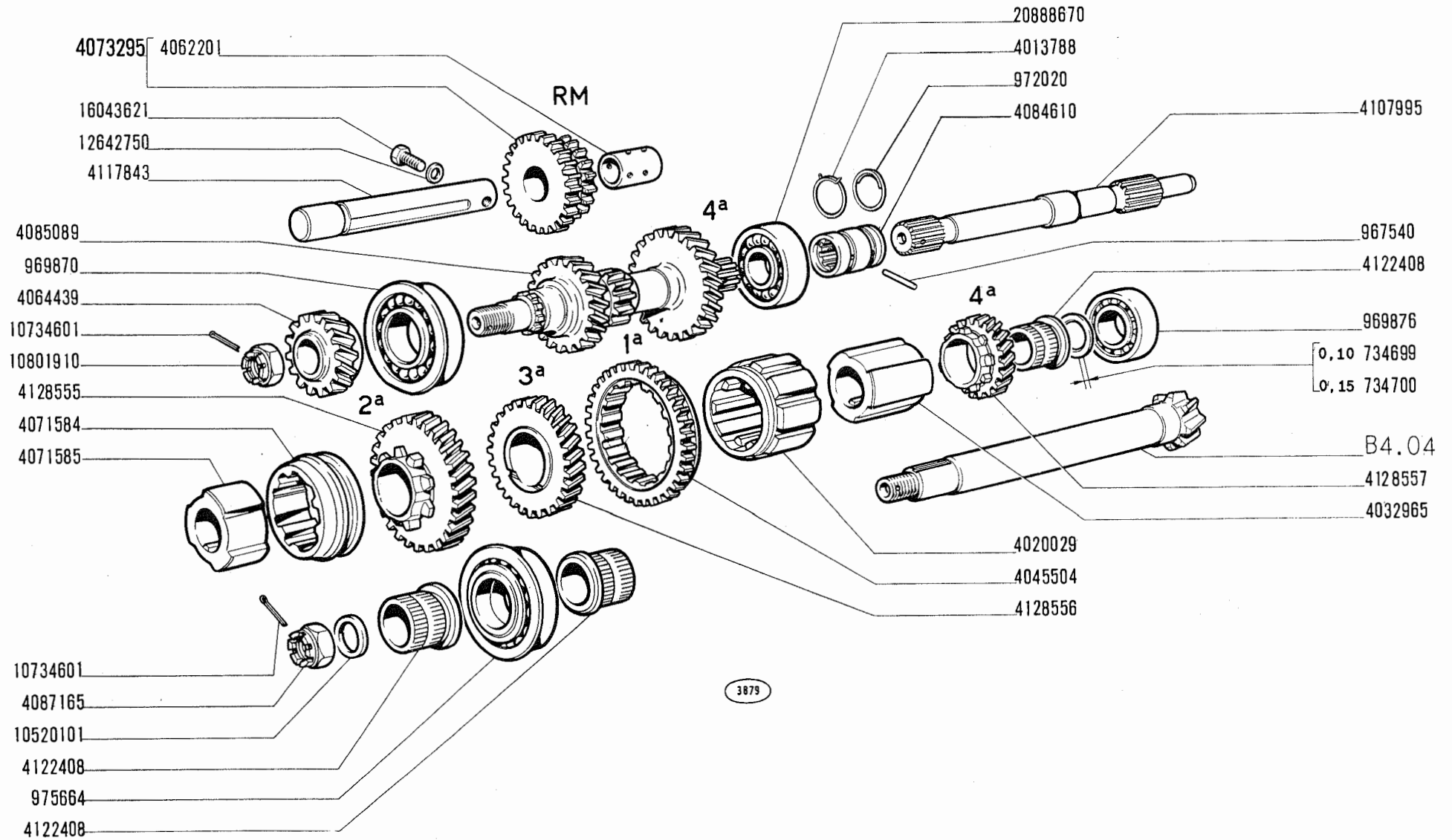

blanchina
panoramica
 e derivati

RUOTISMI CAMBIO DI VELOCITÀ

- Engrenages de boîte de vitesses
- Zahnräder und Wellen des Wechselgetriebes

- Transmission Gears
- Engranajes del cambio

B2.04

modif.	n. ordinaz.	quant.	Denominazione	Désignation	Benennung	Description	Denominaciones
	734699	1.	Rosetta sp. 0,10	Rondelle	Scheibe	Washer	Arandela
	734700	1	Rosetta sp. 0,15	Rondelle	Scheibe	Washer	Arandela
	967540	2	Spina	Goupille	Stift	Pin	Pasador
	969870	1	Cuscinetto sfere	Roulement	Lager	Bearing	Rodamiento
	969876	1	Cuscinetto rulli	Roulement	Lager	Bearing	Rodamiento
	972020	1	Anello elastico	Arrêtoir	Sicherungsring	Lockring	Anillo elástico
	975664	1	Cuscinetto sfere	Roulement	Lager	Bearing	Rodamiento
	4013788	1	Anello elastico	Arrêtoir	Sicherungsring	Lockring	Anillo elástico
	4020029	1	Manicotto 3a. e 4a.	Manchon	Mitnehmer	Sleeve	Manguito
	4032965	1	Mozzo	Moyeu	Nabe	Hub	Buje
	4045504	1	Ingranaggio 1a. e R.M.	Pignon	Zahnrad	Gear	Piñon
	4062201	1	Boccola	Douille	Büchse	Bush	Casquillo
	4064439	1	Ingranaggio 2a.	Pignon	Zahnrad	Gear	Piñon
	4071584	1	Manicotto 2a.	Manchon	Mitnehmer	Sleeve	Corona
	4071585	1	Mozzo	Moyeu	Nabe	Hub	Buje
	4073295	1	Ingranaggio R.M. compl.	Pignon	Zahnrad	Gear	Piñon
	4084610	1	Manicotto	Manchon	Mitnehmer	Sleeve	Manguito
	4085089	1	Albero primario	Arbre	Welle	Shaft	Árbol
	4087165	1	Dado	Écrou	Mutter	Nut	Tuerca
	4107995	1	Albero frizione	Arbre	Welle	Shaft	Árbol
	4117843	1	Albero R.M.	Arbre	Welle	Shaft	Árbol
	4122408	3	Boccola	Douille	Büchse	Bush	Casquillo
	4128555	1	Ingranaggio 2a.	Pignon	Zahnrad	Gear	Piñon
	4128556	1	Ingranaggio 3a.	Pignon	Zahnrad	Gear	Piñon
	4128557	1	Ingranaggio 4a.	Pignon	Zahnrad	Gear	Piñon
	10520101	1	Rosetta piana	Rondelle	Scheibe	Washer	Arandela
	10734601	2	Copiglia spaccata	Goupille	Splint	Pin	Pasador abierto
	10801910	1	Dado	Écrou	Mutter	Nut	Tuerca
	12642750	1	Rosetta piana	Rondelle	Scheibe	Washer	Arandela
	16043621	1	Vite	Vis	Schraube	Screw	Tornillo
	20888670	1	Cuscinetto sfere	Roulement	Lager	Bearing	Rodamiento

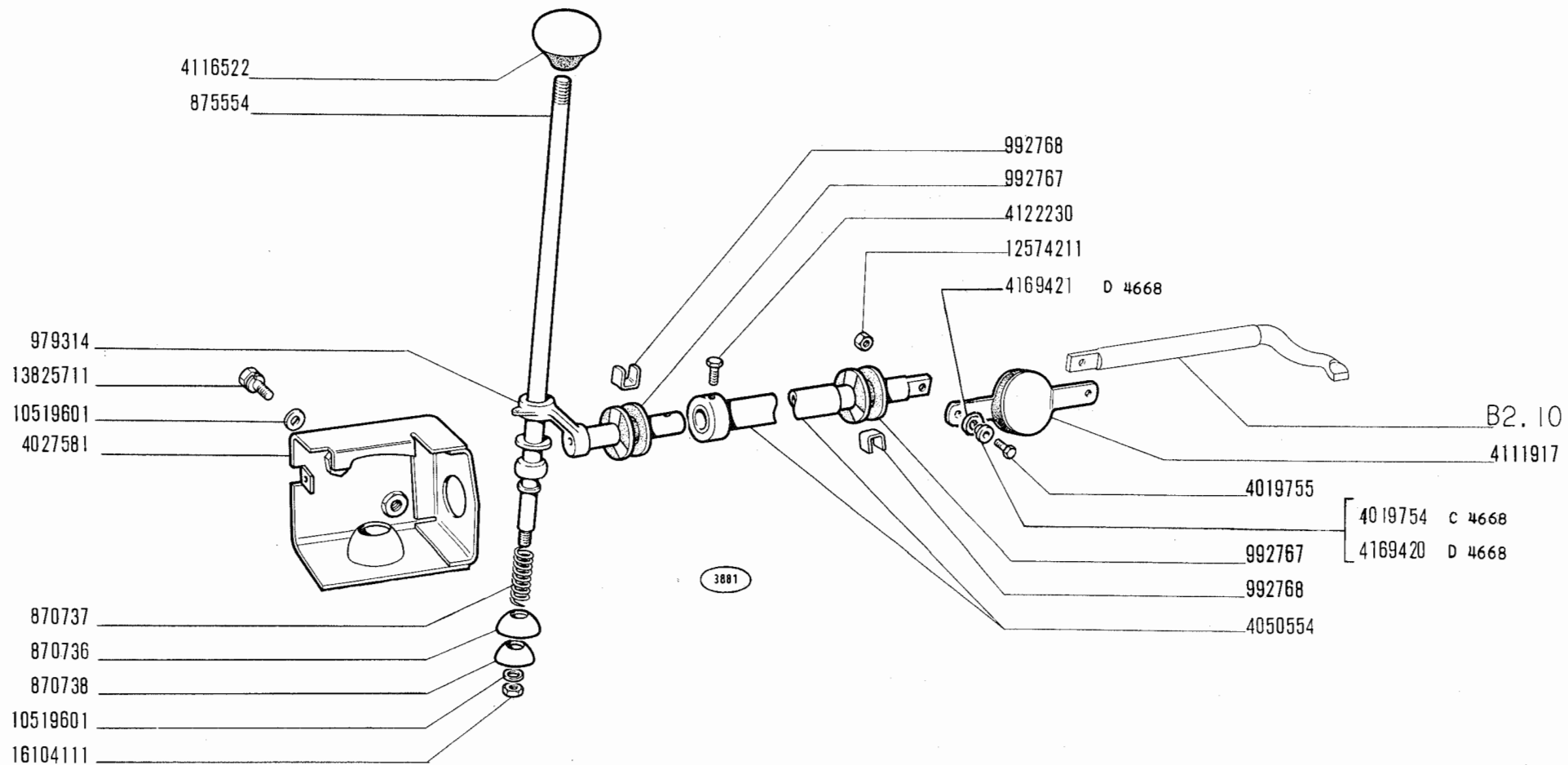

COMANDI ESTERNI CAMBIO DI VELOCITÀ

- Commandes extérieures de boîte de vitesses
- Äussere Getriebeschaltung

- Gearshift Outer Controls
- Varillaje del cambio de velocidades

modif.	n. ordinaz.	quant.	Denominazione	Désignation	Benennung	Description	Denominaciones
	870736	1	Calotta sferica	Calotte	Verteilerkappe	Cap	Tapa
	870737	1	Molla	Ressort	Feder	Spring	Muelle
	870738	1	Scodellino	Cuvette	Tellerscheibe	Cup	Platillo
	875554	1	Leva a mano	Levier	Hebel	Lever	Palanca
	979314	1	Leva	Levier	Hebel	Lever	Palanca
	992767	2	Boccola elastica	Bague caoutchouc	Gummibüchse	Rubber bush	Cojinete
	992768	6	Piastrina	Plaquette	Plättchen	Plate	Placa
C 4668	4019754	2	Boccola	Douille	Büchse	Bush	Casquillo
	4019755	2	Vite	Vis	Schraube	Screw	Tornillo
	4027581	1	Supporto	Support	Lager	Support	Soporte
	4050554	1	Tubo	Tuyau	Rohr	Pipe	Tubo
	4111917	1	Tirante	Tirant	Verbindungsstange	Link	Biela
	4116522	1	Impugnatura	Poignée	Griff	Knob	Botón
	4122230	1	Vite	Vis	Schraube	Screw	Tornillo
D 4668	4169420	2	Boccola	Douille	Büchse	Bush	Casquillo
D 4668	4169421	2	Rosetta	Rondelle	Scheibe	Washer	Arandela
	10519601	3	Rosetta piana	Rondelle	Scheibe	Washer	Arandela
	12574211	2	Dado	Écrou	Mutter	Nut	Tuerca
	13825711	2	Vite	Vis	Schraube	Screw	Tornillo
	16104111	1	Dado	Écrou	Mutter	Nut	Tuerca

4120686
970810

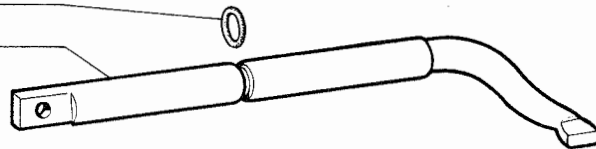

3880

RM

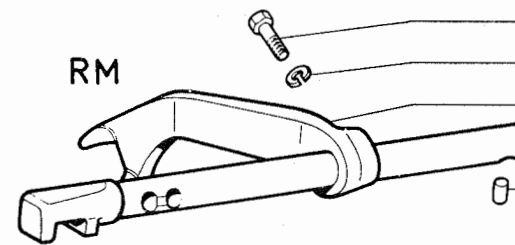

891633
11195470
970803
4107999
355301



4107998
891631
4020031
355301

3^a - 4^a

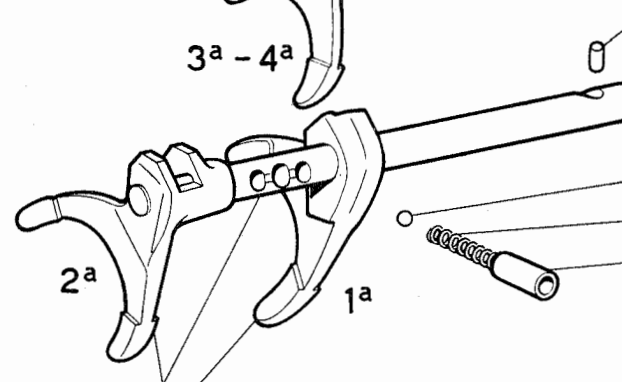

20419310
4169720
983028

4107997
970801

blanchina
panoramica

COMANDI INTERNI CAMBIO DI VELOCITÀ

- *Commandes intérieures de boîte de vitesses*
- *Innere Getriebschaltung*

- *Gearshift Inner Controls*
- *Barras del cambio de velocidades*

B2.10

modif.	n. ordinaz.	quant.	Denominazione	Désignation	Benennung	Description	Denominaciones
	355301	2	Rullo 1a. e 2a.	Galet	Rolle	Roller	Tuerca
	891631	1	Rullo 3a. e 4a.	Galet	Rolle	Roller	Tuerca
	891633	3	Vite	Vis	Schraube	Screw	Tornillo
	970801	1	Forcella 1a.	Fourche	Gabel	Fork	Horquilla
	970803	1	Forcella R.M.	Fourche	Gabel	Fork	Horquilla
	970810	1	Leva	Levier	Hebel	Lever	Palanca
	983028	3	Boccola guida	Douille	Büchse	Bushing	Guía
	4020031	1	Forcella 3a. e 4a.	Fourche	Gabel	Fork	Horquilla
	4107997	1	Asta 1a. e 2a.	Tige	Stange	Rod	Varilla
	4107998	1	Asta 3a. e 4a.	Tige	Stange	Rod	Varilla
	4107999	1	Asta R.M.	Tige	Stange	Rod	Varilla
	4120686	1	Anello tenuta	Joint	Dichtring	Seal	Junta
	4169720	3	Molla	Ressort	Feder	Spring	Muelle
	11195470	3	Rosetta elastica	Rondelle frein	Sicherungsring	Lockwasher	Arandela elástica
	20419310	3	Sfera	Bille	Kugel	Ball	Bola

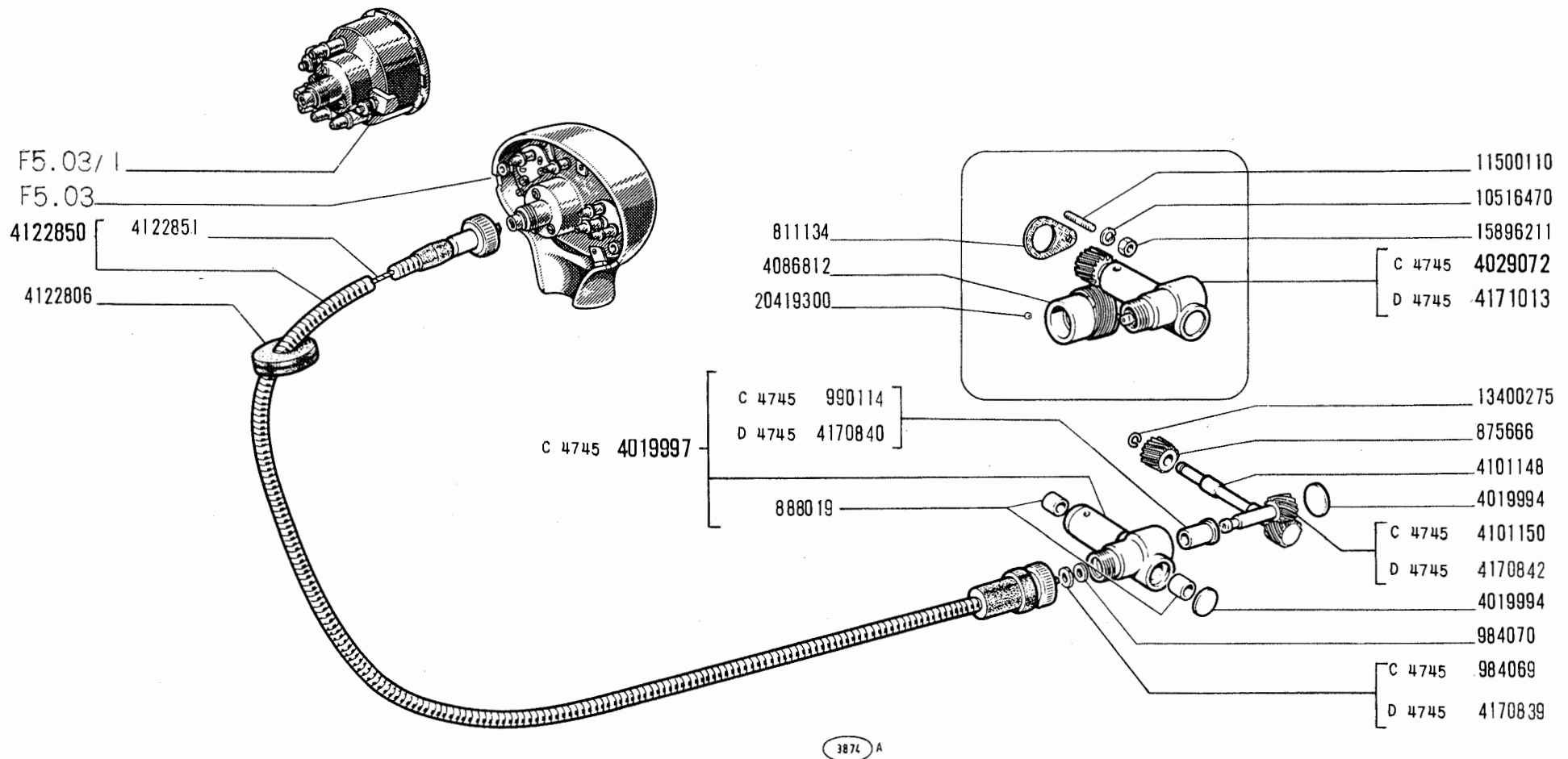

blanchina
panoramica
 e derivati

SEGNALAZIONE VELOCITÀ E SUO COMANDO

- Compteur de vitesse et sa commande
- Tachometer und sein Antrieb

- Speedometer and Drive
- Velocmetro y su arrastre

B2.24

modif.	n. ordinaz.	quant.	Denominazione	Désignation	Benennung	Description	Denominaciones
	811134	1	Guarnizione	Joint	Dichtung	Gasket	Junta
	875666	1	Ingranaggio condotto	Pignon	Zahnrad	Gear	Piñón
	888019	2	Boccola	Douille	Büchse	Bush	Casquillo
C 4745	984069	1	Guarnizione	Joint	Dichtring	Gasket	Junta
	984070	1	Rosetta piana	Rondelle	Scheibe	Washer	Arandela
C 4745	990114	1	Boccola	Douille	Büchse	Bush	Casquillo
	4019994	2	Tappo	Bouchon	Stopfen	Plug	Tapón
C 4745	4019997	1	Supporto compl.	Support	Lager	Support	Soporte
	4029072	1	Supporto compl.	Support	Lager	Support	Soporte
C 4745	4086812	1	Ingranaggio conduttore	Pignon	Zahnrad	Gear	Piñón
	4101148	1	Alberino conduttore	Axe	Welle	Shaft	Eje
C 4745	4101150	1	Alberino condotto	Axe	Welle	Shaft	Eje
	4122806	1	Anello gomma	Bague	Ring	Ring	Guarnición
	4122850	1	Trasmissione compl.	Transmission	Bowdenzug	Flex/shaft	Árbol flexible
	4122851	1	Flessibile	Transmission	Zugdraht	Shaft	Árbol
D 4745	4170839	1	Guarnizione	Joint	Dichtung	Gasket	Junta
D 4745	4170840	1	Boccola	Douille	Büchse	Bush	Casquillo
D 4745	4170842	1	Alberino condotto	Axe	Welle	Shaft	Eje
D 4745	4171013	1	Supporto compl.	Support	Lager	Support	Soporte
	10516470	1	Rosetta elastica	Rondelle	Sicherungsring	Lockwasher	Arandela elástica
	11500110	1	Prigioniero	Goujon	Stiftschraube	Stud	Espárrago
	13400275	1	Anello sicurezza	Arrêtoir	Sicherungsring	Lockring	Anillo elástico
	15896211	1	Dado	Écrou	Mutter	Nut	Tuerca
	20419300	1	Sfera	Bille	Kugel	Ball	Bola

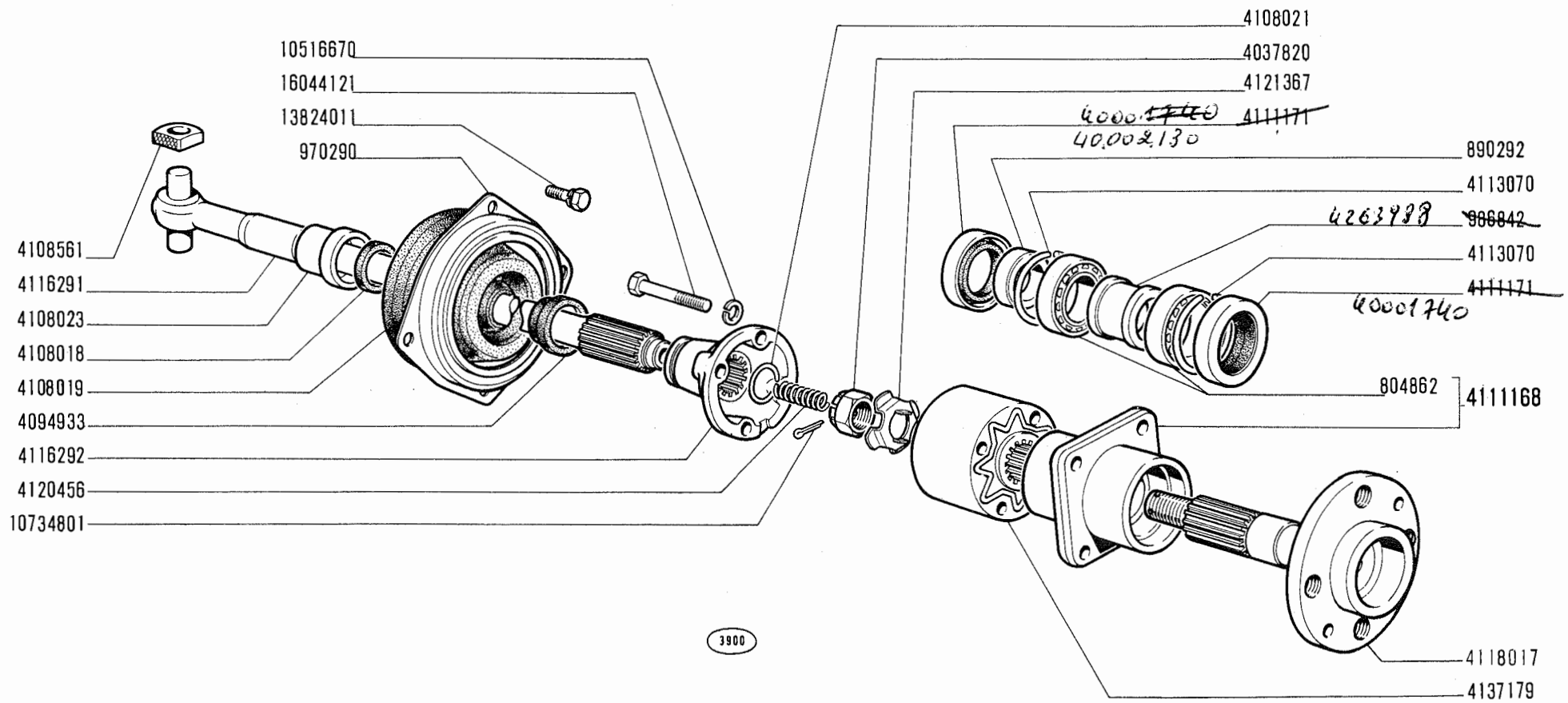

bianchina
panoramica
e derivati

SEMIALBERI DIFFERENZIALE

- Arbres de différentiel
- Achswellen

- Axle Shafts
- Palieres

B4.01

modif.	n. ordinaz.	quant.	Denominazione	Désignation	Benennung	Description	Denominaciones
	804862	4	Cuscinetto rulli	Roulement	Lager	Bearing	Rodamiento
	890292	2	Distanziale	Entretoise	Abstandstück	Spacer	Separador
	970290	2	Coperchio	Couvercle	Deckel	Cover	Tapa
	986842	2	Distanziale centr.	Entretoise	Abstandstück	Spacer	Separador
	4037820	2	Dado	Écrou	Mutter	Nut	Tuerca
	4094933	2	Cappuccio	Capuchon	Schutzkappe	Boot	Capucha
	4108018	2	Guarnizione	Joint	Dichtring	Seal	Junta
	4108019	2	Cuffia	Capuchon	Manschette	Boot	Capucha
	4108021	2	Anello sicurezza	Arrêtoir	Sicherungsring	Lockring	Anillo elástico
	4108023	2	Boccola	Douille	Büchse	Bush	Casquillo
	4108561	4	Pattino	Patin	Gleitstein	Pad	Patin
	4111168	2	Supporto compl.	Support	Lager	Support	Soporte
	4111171	4	Guarnizione	Joint	Dichtring	Seal	Empaquetadura
	4113070	2	Anello sicurezza	Arrêtoir	Sicherungsring	Lockring	Anillo elástico
	4116291	2	Semialbero	Arbre	Welle	Shaft	Árbol
	4116292	2	Manicotto	Manchon	Mitnehmer	Sleeve	Manguito
	4118017	2	Albero	Arbre	Welle	Shaft	Árbol
	4120456	2	Molla	Ressort	Feder	Spring	Muelle
	4121367	2	Piastrina sicurezza	Plaque frein	Sicherungsblech	Lockplate	Placa de freno
	4137179	2	Giunto elastico	Joint élastique	Elast. Kupplung	Flexible joint	Junta elástica
	10516670	8	Rosetta elastica	Rondelle	Sicherungsring	Lockwasher	Arandela elástica
	10734801	2	Copiglia spaccata	Goupille	Splint	Pin	Pasador abierto
	13824011	8	Vite	Vis	Schraube	Screw	Tornillo
	16044121	8	Vite	Vis	Schraube	Screw	Tornillo

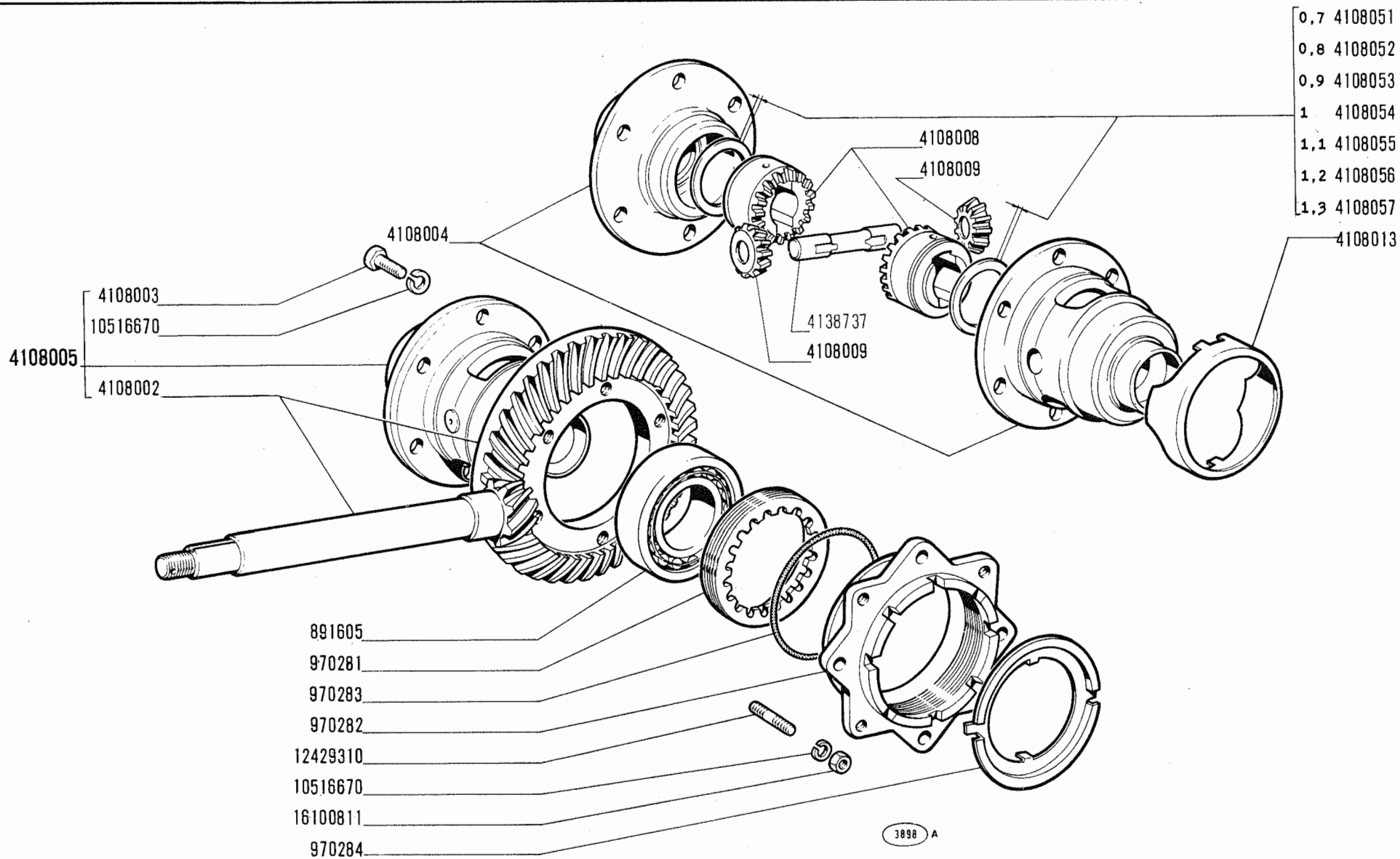

blanchina
panoramica

RUOTISMI RIDUZIONE E DIFFERENZIALE

- Engrenages de réduction et différentiel
- Achsantrieb und Ausgleichgetriebe

- Final Drive and Differential Gears
- Reducción final y diferencial

B4.04

modif.	n. ordinaz.	quant.	Denominazione	Désignation	Benennung	Description	Denominaciones
	891605	2	Cuscinetto rulli	Roulement	Lager	Bearing	Rodamiento
	970281	2	Ghiera	Écrou	Gewinding	Plug	Tornillo
	970282	2	Scatola	Carter	Gehäuse	Case	Caja
	970283	2	Anello tenuta	Joint	Dichtring	Seal	Junta
	970284	2	Anello arresto	Bague	Ring	Ring	Anillo
	4108002	1	Coppia conica - rapp. 8/41 -	Couple conique	Kegelradantrieb	Gear/pinion set	Par cónico
	4108003	6	Vite	Vis	Schraube	Screw	Tornillo
	4108004	1	Scatola	Carter	Gehäuse	Case	Caja
	4108005	1	Scatola compl. - rapp. 8/41 -	Carter	Gehäuse	Case	Caja
	4108008	2	Planetario	Planétaire	Achswellenrad	Sun gear	Piñón planetario
	4108009	2	Satellite	Satellite	Kegelrad	Side gear	Piñón satélite
	4108013	1	Scodellino ritegno	Arrêtoir	Haltering	Retainer	Retenedor
	4108051	2	Anello sp. 0,7	Bague	Ring	Ring	Anillo
	4108052	2	Anello sp. 0,8	Bague	Ring	Ring	Anillo
	4108053	2	Anello sp. 0,9	Bague	Ring	Ring	Anillo
	4108054	2	Anello sp. 1,0	Bague	Ring	Ring	Anillo
	4108055	2	Anello sp. 1,1	Bague	Ring	Ring	Anillo
	4108056	2	Anello sp. 1,2	Bague	Ring	Ring	Anillo
	4108057	2	Anello sp. 1,3	Bague	Ring	Ring	Anillo
	4138737	1	Perno	Axe	Bolzen	Pin	Eje
	10516670	14	Rosetta elastica	Rondelle	Sicherungsring	Lockwasher	Arandela elástica
	12429310	8	Prigioniero	Goujon	Stiftschraube	Stud	Espárrago
	16100811	8	Dado	Écrou	Mutter	Nut	Tuerca

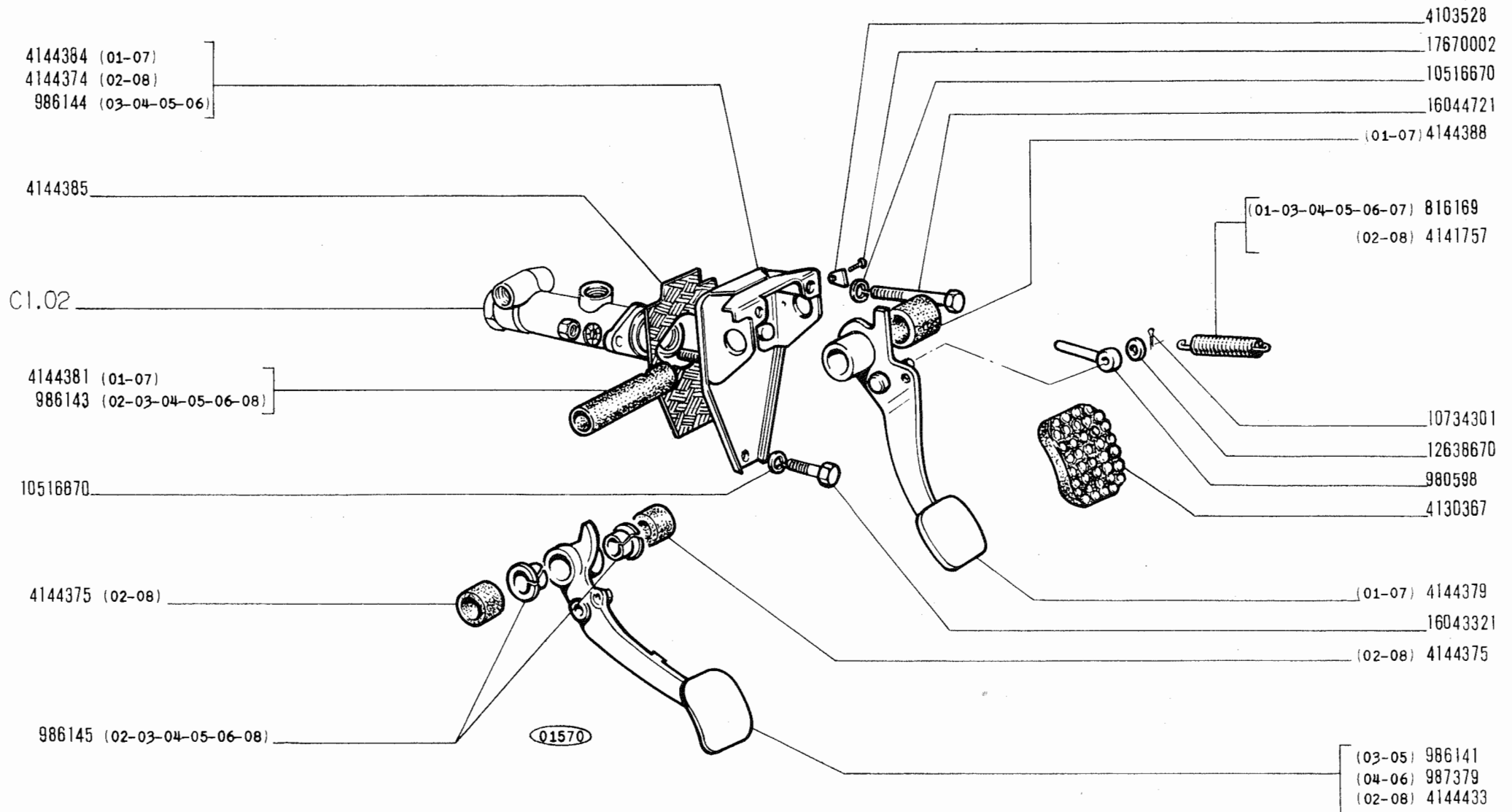

D 4121 Vett.n. 119835 (01-02-03-04) - Vett.n. 000484 (05-06) - Vett.n. 185063 (07-08) →

blanchina
panoramica
e derivati

COMANDO A PEDALE FRENI

- *Commande au pied de freins*
- *Bremsfusshebel*

- *Brake Foot Control*
- *Pedal de freno*

C1.01

modif.	n. ordinaz.	quant.	Denominazione	Désignation	Benennung	Description	Denominaciones
	816169	1	Molla richiamo - 01 - 03 - 04 - 05 - 06 - 07 -	Ressort	Feder	Spring	Muelle
	980598	1	Puntalino	Tige	Stössel	Rod	Vástago
	986141	1	Pedale - 03 - 05 -	Pédale	Fusshebel	Pedal	Pedal
	986143	1	Perno - 02 - 03 - 04 - 05 - 06 - 08	Axe	Bolzen	Pin	Eje
	986144	1	Supporto - 03 - 04 - 05 - 06 -	Support	Lager	Support	Soporte
	986145	2	Boccola - 02 - 03 - 04 - 05 - 06 - 08 -	Douille	Büchse	Bush	Casquillo
	987379	1	Pedale - 04 - 06 -	Pédale	Fusshebel	Pedal	Pedal
	4103528	1	Piastrina	Bride	Plättchen	Plate	Placa
	4130367	1	Copripedale gomma	Caoutchouc	Fusshebelüberzug	Pad	Forro
	4141757	1	Molla richiamo - 02 - 08 -	Ressort	Feder	Spring	Muelle
	4144374	1	Supporto - 02 - 08 -	Support	Lager	Support	Soporte
	4144375	2	Distanziale - 02 - 08 -	Entretoise	Abstandstück	Spacer	Separador
	4144379	1	Pedale - 01 - 07 -	Pédale	Fusshebel	Pedal	Pedal
	4144381	1	Perno - 01 - 07	Axe	Bolzen	Pin	Eje
	4144384	1	Supporto - 01 - 07 -	Support	Lager	Support	Soporte
	4144385	1	Guarnizione	Joint	Dichtung	Gasket	Junta
	4144388	1	Distanziale - 01 - 07 -	Entretoise	Abstandstück	Spacer	Separador
	4144433	1	Pedale - 02 - 08 -	Pédale	Fusshebel	Pedal	Pedal
	10516670	3	Rosetta elastica	Rondelle frein	Sicherungsring	Lockwasher	Arandela elástica
	10734301	1	Copiglia spaccata	Goupille	Splint	Split pin	Pasador abierto
	12638670	1	Rosetta piana	Rondelle	Scheibe	Washer	Arandela
	16043321	1	Vite inf.	Vis	Schraube	Screw	Tornillo
	16044721	2	Vite sup.	Vis	Schraube	Screw	Tornillo
	17670002	1	Vite	Vis	Schraube	Screw	Tornillo

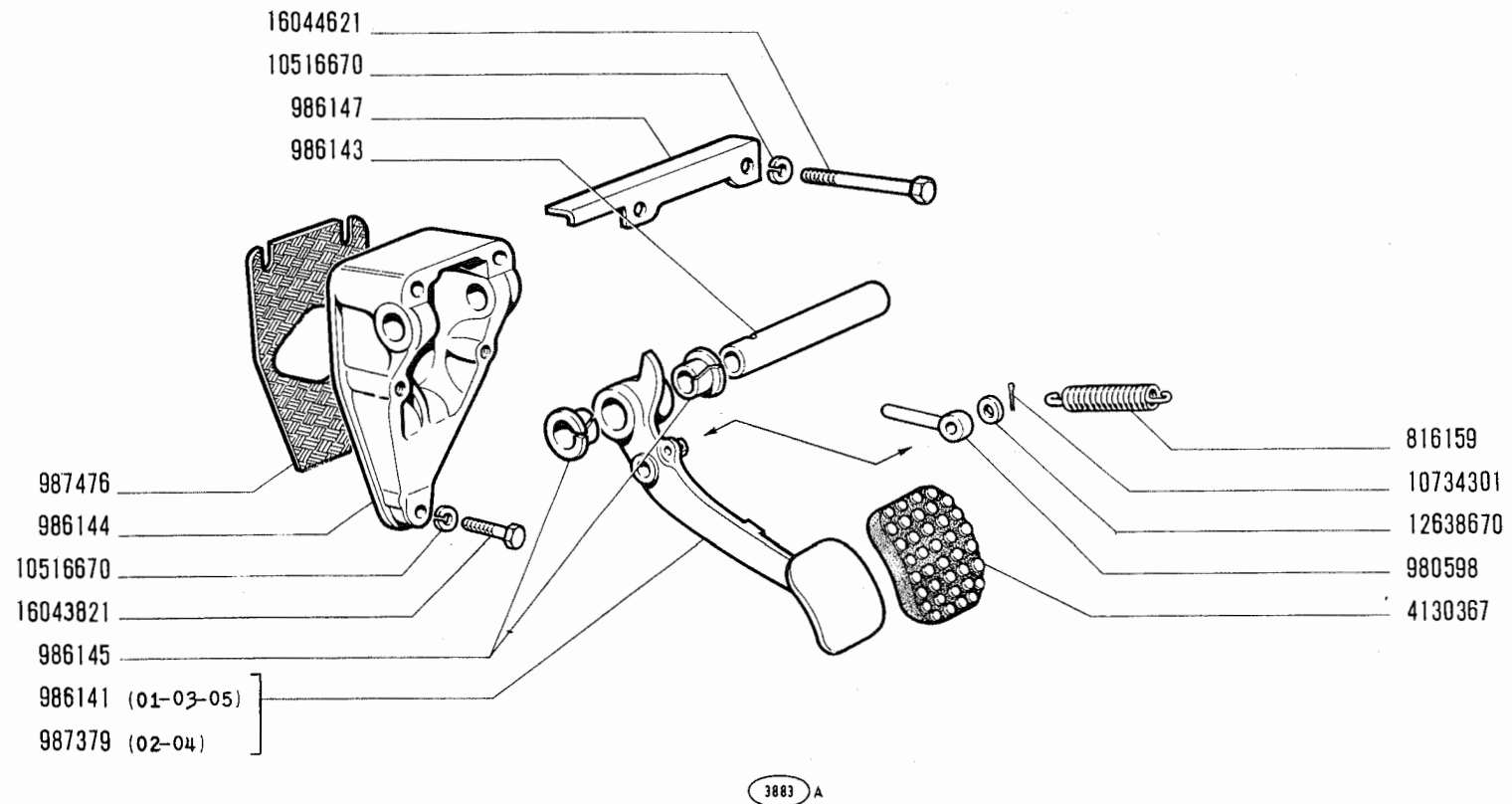

C 4121 → Vett. n. 119834 (01-02-03-04) - Vett. n. 000483 (05-06) - Vett. n. 185062 (07-08)

bianchina
panoramica
e derivati

COMANDO A PEDALE FRENI

- *Commande au pied de freins*
- *Bremsfusshebel*

- *Brake Foot Control*
- *Pedal de freno*

C1.01/1

modif.	n. ordinaz.	quant.	Denominazione	Désignation	Benennung	Description	Denominaciones
	816159	1	Molla richiamo	Ressort	Feder	Spring	Muelle
	980598	1	Puntalino	Tige	Druckstange	Rod	Vástago
	986141	1	Pedale - 01 - 03 - 05 -	Pédale	Fusshebel	Pedal	Pedal
	986143	1	Perno	Axe	Bolzen	Pin	Eje
	986144	1	Supporto	Support	Lager	Support	Soporte
	986145	2	Boccola	Douille	Büchse	Bush	Casquillo
	986147	1	Squadretta	Équerre	Halter	Bracket	Apoyo
	987379	1	Pedale - 02 - 04 -	Pédale	Fusshebel	Pedal	Pedal
	987476	2	Guarnizione	Joint	Dichtung	Gasket	Junta
	4130367	1	Copripedale gomma	Caoutchouc	Fusshebelüberzug	Pad	Forro
	10516670	3	Rosetta elastica	Rondelle frein	Sicherungsring	Lockwasher	Arandela elástica
	10734301	1	Copiglia spaccata	Goupille	Splint	Pin	Pasador abierto
	12638670	1	Rosetta piana	Rondelle	Scheibe	Washer	Arandela
	16043821	1	Vite inf.	Vis	Schraube	Screw	Tornillo
	16044621	2	Vite sup.	Vis	Schraube	Screw	Tornillo

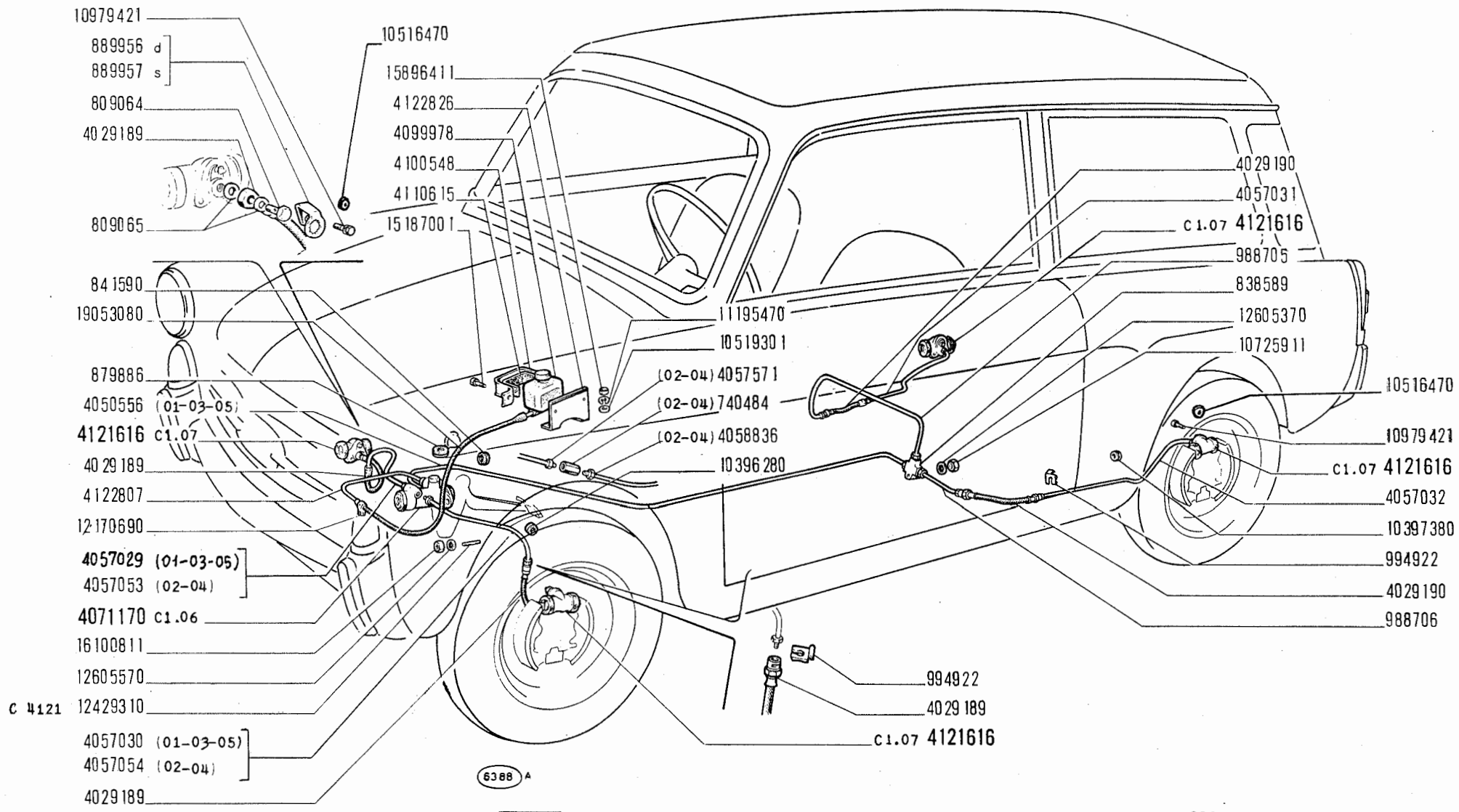

C 4678 → Vett.n. 152490 (01-02-03-04) - Vett.n. 002609 (05-06) - Vett.n. 299233 (07-08)

blanchina
panoramica
 e derivati

COMANDO IDRAULICO FRENI

- *Commande hydraulique de freins*
- *Hydraulische Bremsbetätigung*

- *Brake Hydraulic System*
- *Sistema de freno hidráulico*

C1.02

modif.	n. ordinaz.	quant.	Denominazione	Désignation	Benennung	Description	Denominaciones
	740484	1	Raccordo - 02 - 04 -	Raccord	Stutzen	Connection	Racor
	809064	2	Bocchettone	Vis-raccord	Hohlschraube	Union	Boquilla
	809065	4	Rosetta di tenuta	Joint	Dichtring	Gasket	Junta
	838589	1	Raccordo 3 vie	Raccord	Stutzen	Connection	Racor
	841590	1	Anello isolante	Isolant	Isolerring	Insulator	Guarnición
	879886	1	Guarnizione	Joint	Dichtung	Gasket	Guarnición
	889956	1	Piastrina d	Plaque	Plättchen	Plate	Placa
	889957	1	Piastrina s	Plaque	Plättchen	Plate	Placa
	988705	1	Tubo post. d	Tuyau	Rohr	Pipe	Tubo
	988706	1	Tubo post. s	Tuyau	Rohr	Pipe	Tubo
	994922	6	Piastrina elastica	Agrafe	Klemmstück	Clip	Sujetador
	4029189	2	Tubo flessibile	Tuyau	Schlauch	Hose	Tubo flexible
	4029190	2	Tubo flessibile	Tuyau	Schlauch	Hose	Tubo flexible
	4050556	1	Tubo post. - 01 - 03 - 05 -	Tuyau	Rohr	Pipe	Tubo
	4057029	1	Tubo ant. d - 01 - 03 - 05 -	Tuyau	Rohr	Pipe	Tubo
	4057030	1	Tubo ant. s - 01 - 03 - 05 -	Tuyau	Rohr	Pipe	Tubo
	4057031	1	Tubo post. d	Tuyau	Rohr	Pipe	Tubo
	4057032	1	Tubo post. s	Tuyau	Rohr	Pipe	Tubo
	4057053	1	Tubo ant. d - 02 - 04 -	Tuyau	Rohr	Pipe	Tubo
	4057054	1	Tubo ant. s - 02 - 04 -	Tuyau	Rohr	Pipe	Tubo
	4057571	1	Tubo post. - 02 - 04 -	Tuyau	Rohr	Pipe	Tubo
	4058836	1	Tubo post. - 02 - 04 -	Tuyau	Rohr	Pipe	Tubo
	4071170	1	Cilindro maestro compl.	Maitre-cylindre	Hauptzylinder	Master cylinder	Bomba
	4099978	1	Serbatoio	Réservoir	Behälter	Tank	Depósito
	4100548	1	Staffa	Étrier	Halter	Bracket	Soporte
	4110615	1	Guarnizione	Caoutchouc	Profilgummi	Weatherstrip	Goma
	4121616	4	Cilindro compl.	Cylindre de roue	Radbremsszylinder	Wheel cylinder	Cilindro de freno
	4122807	1	Tubo al cilindro	Tuyau	Rohr	Pipe	Tubo
	4122826	1	Staffa	Étrier	Halter	Bracket	Soporte
	10396280	2	Anello isolante	Bague	Isolerring	Insulator	Guarnición
	10397380	2	Anello isolante	Bague	Isolerring	Insulator	Guarnición
	10519301	2	Rosetta piana	Rondelle	Scheibe	Washer	Arandela
	10516470	8	Rosetta elastica	Rondelle	Sicherungsring	Lockwasher	Arandela elástica
	10725911	1	Dado	Écrou	Mutter	Nut	Tuerca
	10979421	8	Vite	Vis	Schraube	Screw	Tornillo
	11195470	2	Rosetta elastica	Rondelle	Sicherungsring	Lockwasher	Arandela elástica

modif.	n. ordinaz.	quant.	Denominazione	Désignation	Benennung	Description	Denominaciones
C 4121	12170690	2	Collare	Collier	Schelle	Collar	Abrazadera
	12429310	2	Prigioniero	Goujon	Stiftschraube	Stud	Espárrago
	12605370	1	Rosetta dentata	Rondelle frein	Sicherungsring	Lockwasher	Arandela dentada
	12605570	2	Rosetta dentata	Rondelle frein	Sicherungsring	Lockwasher	Arandela dentada
	15187001	2	Vite	Vis	Schraube	Screw	Tornillo
	15896411	2	Dado	Écrou	Mutter	Nut	Tuerca
	16100811	2	Dado	Écrou	Mutter	Nut	Tuerca
	19053080	m	Tube 5 x 9	Tuyau	Schlauch	Hose	Tube

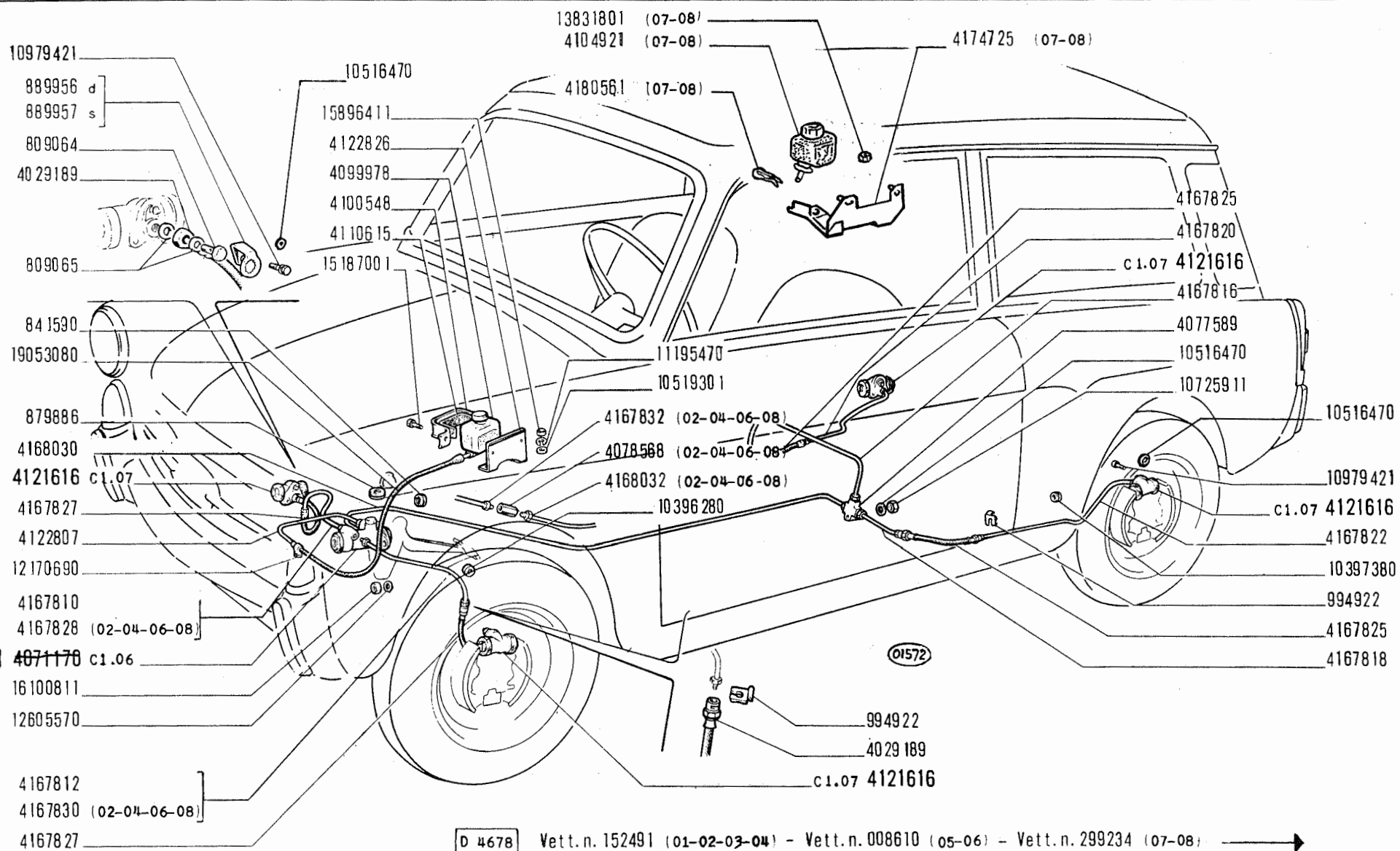

**blanchina
panoramica**

COMANDO IDRAULICO FRENI

- *Commande hydraulique de freins*
- *Hydraulische Bremsbetätigung*

- *Brake Hydraulic System*
- *Sistema de freno hidráulico*

C1.02/1

modif.	n. ordinaz.	quant.	Denominazione	Désignation	Benennung	Description	Denominaciones
	809064	2	Bocchettone	Vis-raccord	Hohlschraube	Union	Racor
	809065	4	Rosetta di tenuta	Joint	Dichtring	Seal	Junta
	841590	1	Anello isolante	Isolant	Isolierring	Insulator	Guarnición
	879886	1	Guarnizione	Joint	Dichtung	Gasket	Junta
	889956	1	Piastrina d	Plaquette	Plättchen	Plate	Placa
	889957	1	Piastrina s	Plaquette	Plättchen	Plate	Placa
	994922	6	Piastrina elastica	Agrafe	Klemmstück	Clip	Sujetador
	4029189	2	Tubo flessibile	Tuyau	Schlauch	Hose	Tubo flexible
	4071170	1	Cilindro maestro compl.	Maitre-cylindre	Hauptzylinder	Master cylinder	Bomba de freno
	4077589	1	Raccordo 3 vie	Raccord 3 voies	Stutzen	Connection	Racor
	4078568	1	Raccordo - 02 - 04 - 06 - 08 -	Raccord	Stutzen	Connection	Racor
	4099978	1	Serbatoio - 01 - 02 - 03 - 04 - 05 - 06 -	Réservoir	Behälter	Tank	Depósito
	4100548	1	Staffa	Etrier	Halter	Bracket	Abrazadera
	4104921	1	Serbatoio - 07 - 08 -	Réservoir	Behälter	Tank	Depósito
	4110615	1	Guarnizione	Joint	Dichtung	Gasket	Junta
	4121616	4	Cilindro compl.	Cylindre	Zylinder	Wheel cylinder	Cilindro de freno
	4122807	1	Tubo al cilindro	Tuyau	Rohr	Pipe	Tubo
	4122826	1	Staffa	Etrier	Halter	Bracket	Soporte
	4167810	1	Tubo ant. d	Tuyau	Rohr	Pipe	Tubo
	4167812	1	Tubo ant. s	Tuyau	Rohr	Pipe	Tubo
	4167816	1	Tubo post. d	Tuyau	Rohr	Pipe	Tubo
	4167818	1	Tubo post. s	Tuyau	Rohr	Pipe	Tubo
	4167820	1	Tubo post. d	Tuyau	Rohr	Pipe	Tubo
	4167822	1	Tubo post. s	Tuyau	Rohr	Pipe	Tubo
	4167825	2	Tubo flessibile	Tuyau	Schlauch	Hose	Tubo flexible
	4167827	2	Tubo flessibile	Tuyau	Schlauch	Hose	Tubo flexible
	4167828	1	Tubo ant. d - 02 - 04 - 06 - 08 -	Tuyau	Rohr	Pipe	Tubo
	4167830	1	Tubo ant. s - 02 - 04 - 06 - 08 -	Tuyau	Rohr	Pipe	Tubo
	4167832	1	Tubo post. - 02 - 04 - 06 - 08 -	Tuyau	Rohr	Pipe	Tubo
	4168030	1	Tubo post. - 01 - 03 - 05 - 07 -	Tuyau	Rohr	Pipe	Tubo
	4168032	1	Tubo post. - 02 - 04 - 06 - 08 -	Tuyau	Rohr	Pipe	Tubo
	4174725	1	Staffa - 07 - 08 -	Etrier	Halter	Bracket	Soporte
	4180561	1	Molletta - 07 - 08 -	Agrafe	Klemmstück	Spring	Sujetador
	10396280	2	Anello isolante	Bague	Isolierring	Insulator	Guarnición

modif.	n. ordinaz.	quant.	Denominazione	Désignation	Benennung	Description	Denominaciones
	10397380	2	Anello isolante	Bague	Isolerring	Insulator	Gaurnición
	10516470	8	Rosetta	Rondelle	Scheibe	Washer	Arandela
	10519301	2	Rosetta piana	Rondelle	Scheibe	Washer	Arandela
	10725911	1	Dado	Ecrou	Mutter	Nut	Tuerca
	10979421	8	Vite	Vis	Schraube	Screw	Tornillo
	11195470	2	Rosetta elastica	Rondelle frein	Sicherungsring	Lockwasher	Arandela elástica
	12170690	2	Collare	Collier	Schelle	Collar	Abrazadera
	12605570	2	Rosetta dentata	Rondelle	Sicherungsring	Lockwasher	Arandela dentada
	13831801	2	Dado - 07 - 08 -	Ecrou	Mutter	Nut	Tuerca
	15187001	2	Vite	Vis	Schraube	Screw	Tornillo
	15896411	2	Dado	Ecrou	Mutter	Nut	Tuerca
	16100811	2	Dado	Ecrou	Mutter	Nut	Tuerca
	19053080	M	Tubo 5 x 9	Tuyau	Schlauch	Tube	Tubo

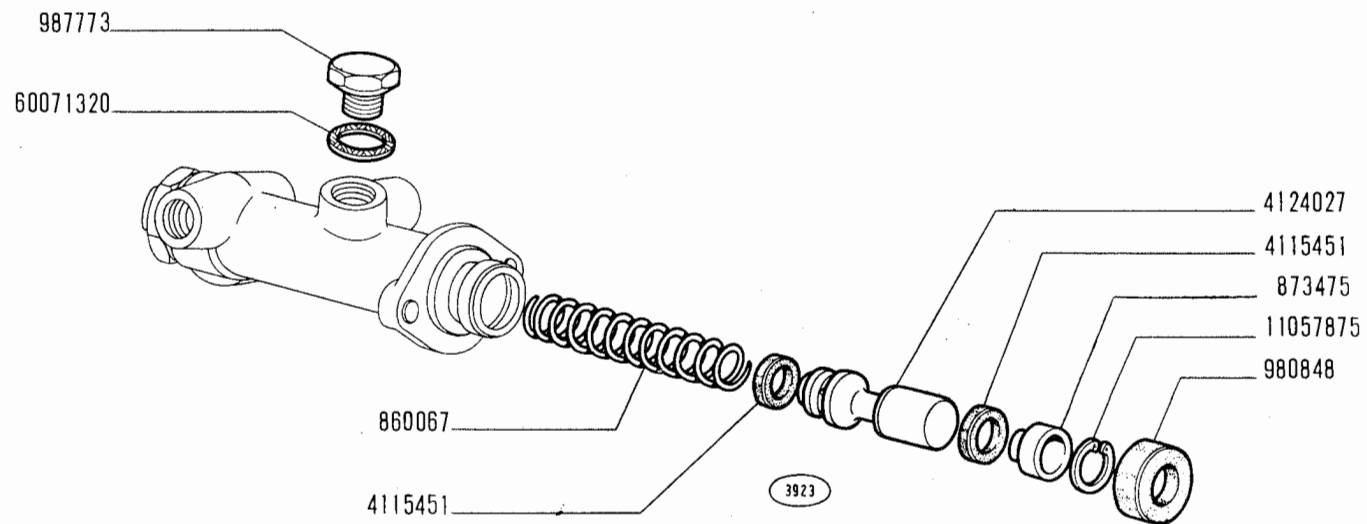

bianchina
panoramica

- Maître-cylindre
- Hauptzylinder

CILINDRO MAESTRO 4071170

- Master Cylinder
- Bomba

C1.06

modif.	n. ordinaz.	quant.	Denominazione	Désignation	Benennung	Description	Denominaciones
	860067	1	Molla	Ressort	Feder	Spring	Resorte
	873475	1	Stantuffo	Piston	Kolben	Piston	Émbolo
	980848	1	Cuffia	Capuchon	Manschette	Boot	Capuchón
	987773	1	Tappo	Bouchon	Stopfen	Plug	Tapón
	4115451	2	Anello tenuta	Joint	Dichtring	Seal	Junta
	4124027	1	Flottante	Flotteur	Ventilträger	Carrier	Válvula flotante
	11057875	1	Anello sicurezza	Arrêtoir	Sicherungsring	Lockring	Anillo elástico
	60071320	1	Rosetta tenuta	Joint	Dichtring	Gasket	Junta

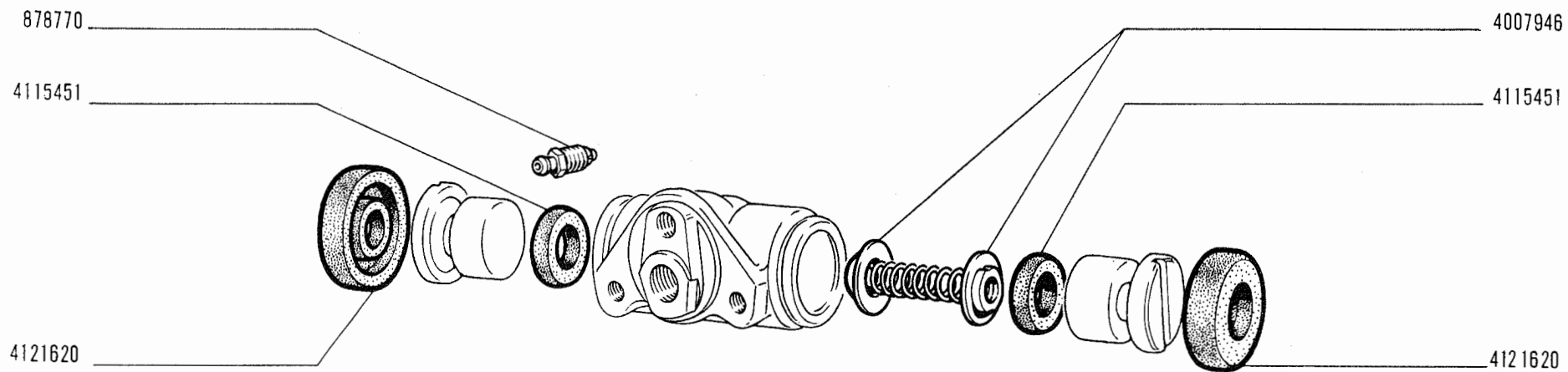

3152

CILINDRO COMANDO GANASCE 4121616

- *Cylindre de commande mâchoires*
- *Radbremssylinder*

- *Wheel Cylinder*
- *Cilindro de freno*

modif.	n. ordinaz.	quant.	Denominazione	Désignation	Benennung	Description	Denominaciones
	878770	1	Vite di spurgo	Vis	Schraube	Screw	Tornillo
	4007946	1	Premiguarnizione	Presse-joint	Druckfeder	Expander	Elemento separador
	4115451	2	Anello tenuta	Joint	Dichtring	Seal	Junta
	4121620	2	Cuffia	Capuchon	Manschette	Boot	Capuchón

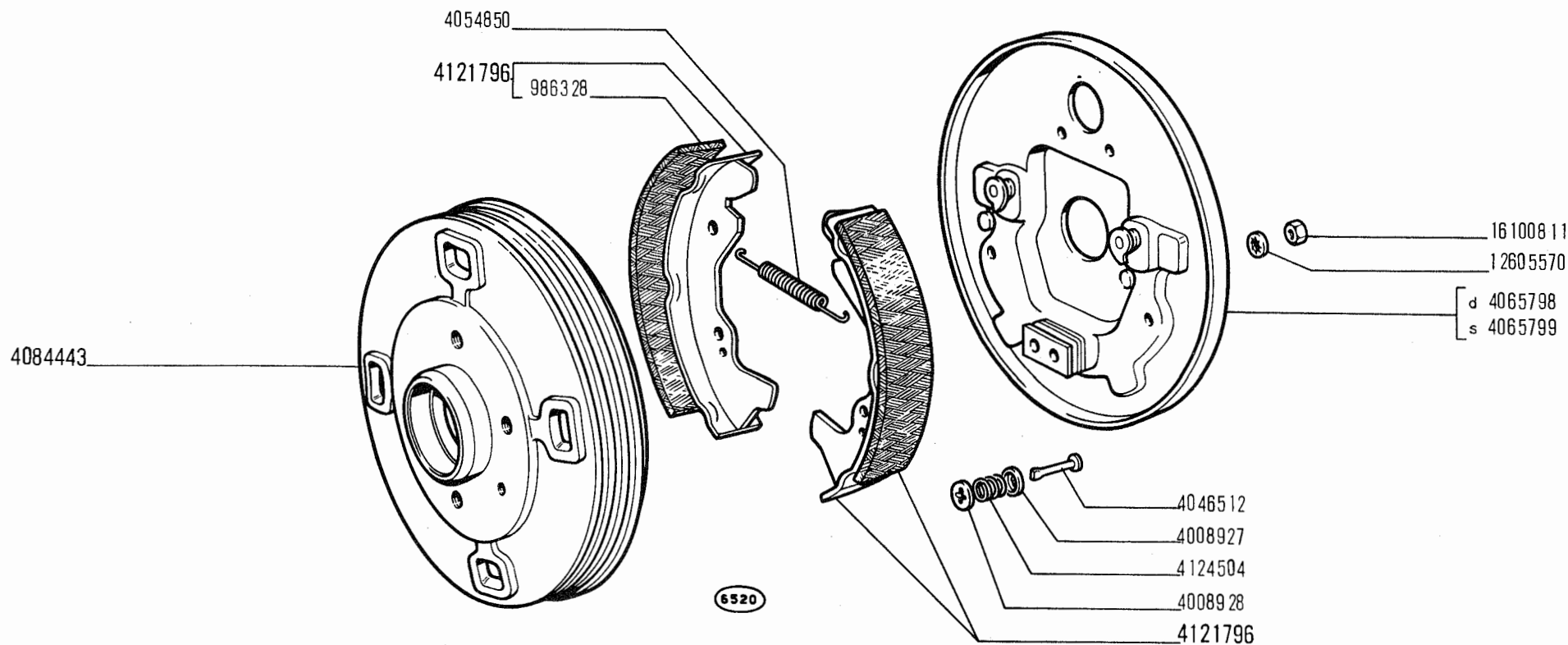

FRENI RUOTE ANTERIORI

modif.	n. ordinaz.	quant.	Denominazione	Désignation	Benennung	Description	Denominaciones
	986328	4	Segmento	Garniture	Belag	Lining	Forro
	4008927	4	Scodellino int.	Cuvette	Tellerscheibe	Cup	Platillo
	4008928	4	Scodellino est.	Cuvette	Tellerscheibe	Cup	Platillo
	4046512	4	Perno	Axe	Bolzen	Pin	Eje
	4054850	4	Molla richiamo	Ressort	Feder	Spring	Muelle
	4065798	1	Disco d	Disque	Bremsträger	Plate	Disco
	4065799	1	Disco s	Disque	Bremsträger	Plate	Disco
	4084443	2	Tamburo compl.	Tambour	Trommel	Drum	Tambor
	4121796	4	Ganascia compl.	Mâchoire	Bremsbacke	Shoe	Zapata
	4124504	4	Molla	Ressort	Feder	Spring	Muelle
	12605570	4	Rosetta dentata	Rondelle frein	Sicherungsring	Lockwasher	Arandela dentada
	16100811	4	Dado	Écrou	Mutter	Nut	Tuerca

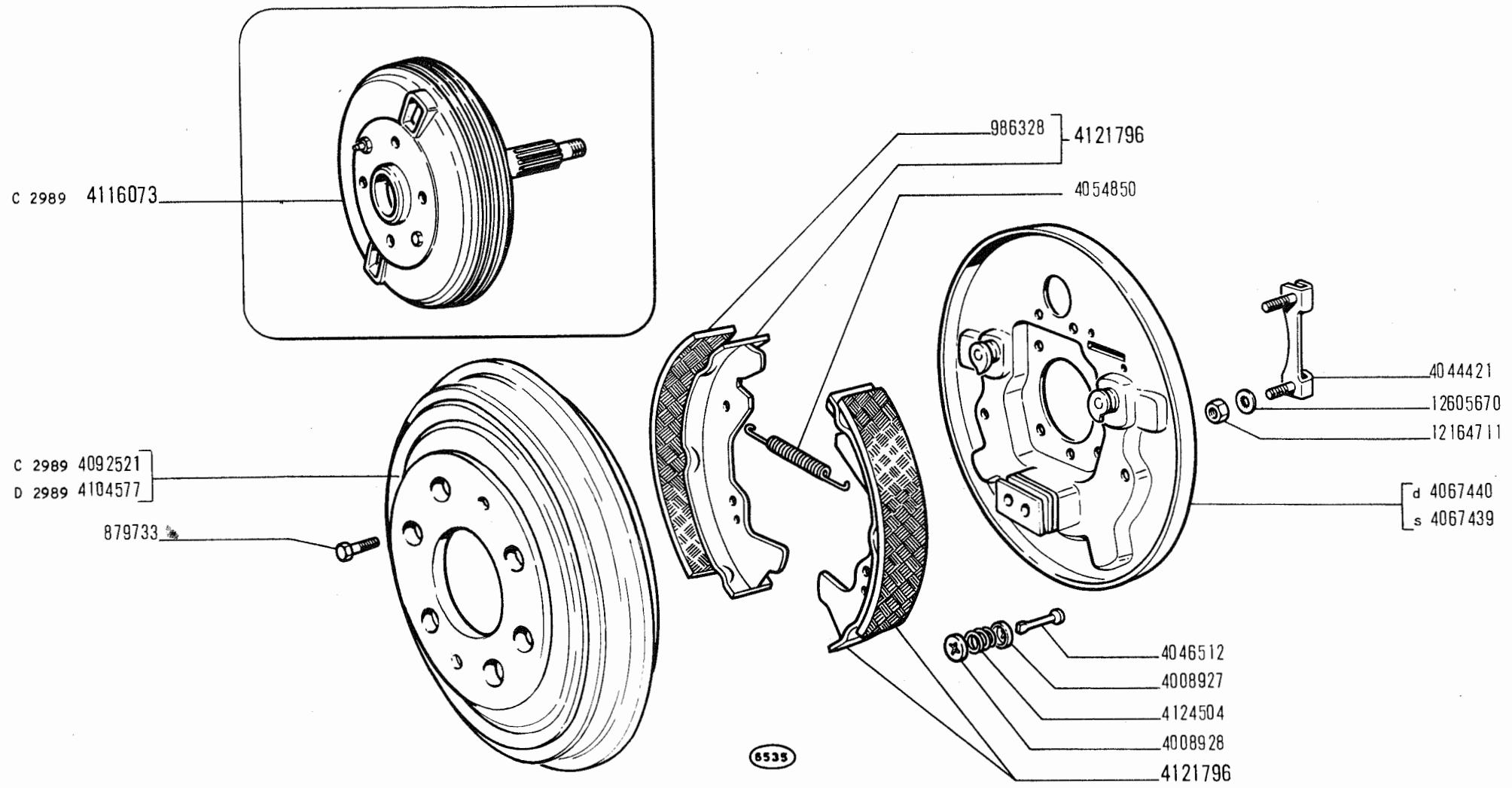

bianchina
panoramica
e derivati

FRENI RUOTE POSTERIORI

- Freins de roues AR
- Hinterradbremsen

- Rear Wheel Brakes
- Frenos posteriores

C1.32

modif.	n. ordinaz.	quant.	Denominazione	Désignation	Benennung	Description	Denominaciones
	879733	2	Vite	Vis	Schraube	Screw	Tornillo
	986328	4	Segmento	Garniture	Belag	Lining	Forro
	4008927	4	Scodellino int.	Cuvette	Tellerscheibe	Cup	Platillo
	4008928	4	Scodellino est.	Cuvette	Tellerscheibe	Cup	Platillo
	4044421	4	Piastrina	Plaquette frein	Sicherungsblech	Lockplate	Placa de freno
	4046512	4	Perno	Axe	Bolzen	Pin	Eje
	4054850	4	Molla richiamo	Ressort	Feder	Spring	Muelle
	4067439	1	Disco s	Disque	Bremsträger	Plate	Disco
	4067440	1	Disco d	Disque	Bremsträger	Plate	Disco
C 2989	4092521	2	Tamburo	Tambour	Trommel	Drum	Tambor
D 2989	4104577	2	Tamburo	Tambour	Trommel	Drum	Tambor
C 2989	4116073	2	Tamburo compl.	Tambour	Trommel	Drum	Tambor
	4121796	4	Ganascia compl.	Mâchoire	Bremsbacke	Shoe	Zapata
	4124504	4	Molla	Ressort	Feder	Spring	Muelle
	12164711	8	Dado	Écrou	Mutter	Nut	Tuerca
	12605670	8	Rosetta dentata	Rondelle frein	Sicherungsring	Lockwasher	Arandela dentada

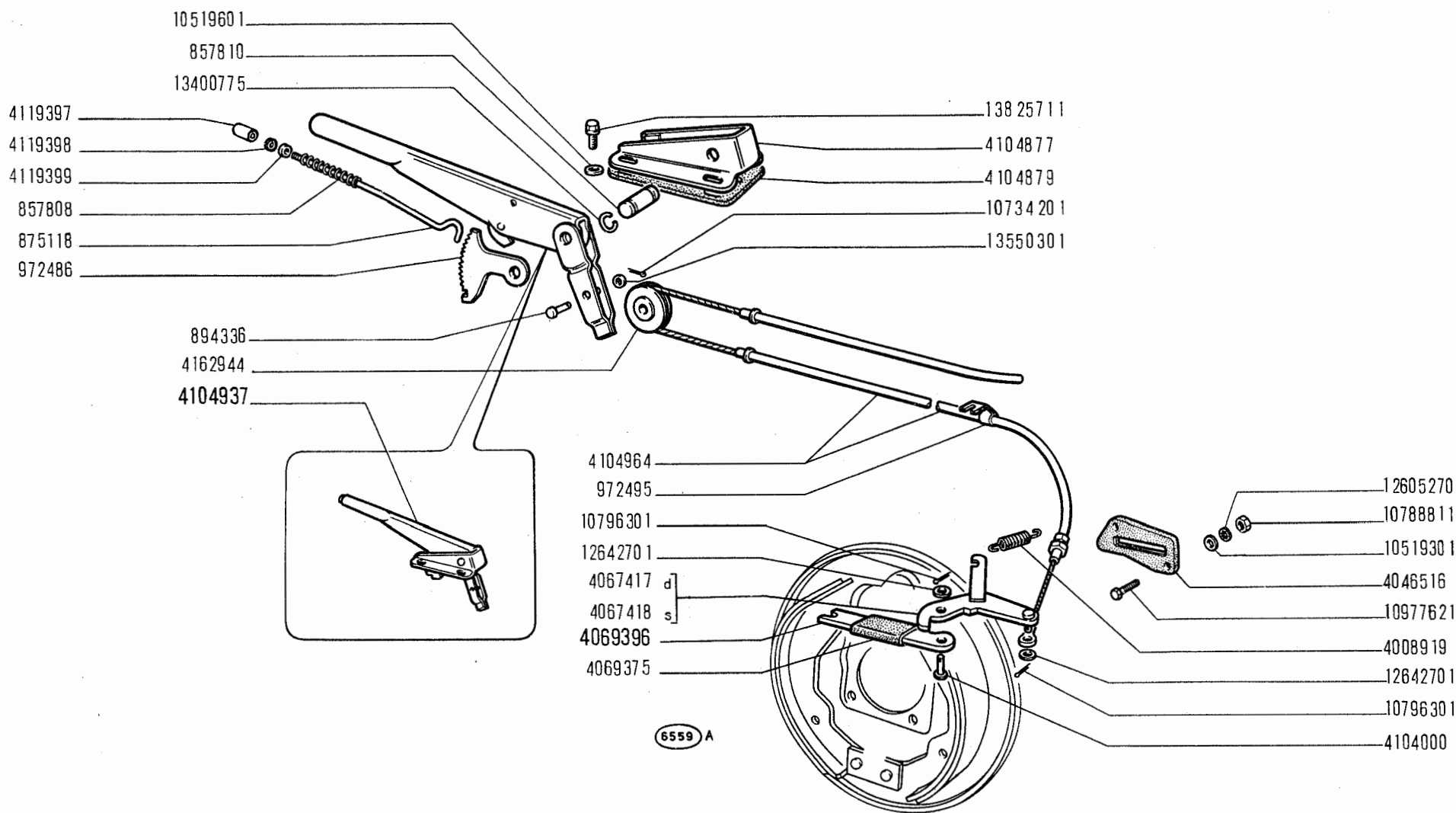

blanchina
panoramica
 e derivati

COMANDO A MANO FRENI

- *Commande de freins à main*
- *Handbremsbetätigung*

- *Brake Hand Control*
- *Freno de mano*

C1.35

modif.	n. ordinaz.	quant.	Denominazione	Désignation	Benennung	Description	Denominaciones
	857808	1	Molla	Ressort	Feder	Spring	Muelle
	857810	1	Perno	Axe	Bolzen	Pin	Eje
	875118	1	Asticina	Tige	Stange	Rod	Varilla
	894336	1	Perno	Axe	Bolzen	Pin	Eje
	972486	1	Settore dentato	Secteur	Zahnbogen	Sector	Rueda
	972495	2	Staffetta	Collier	Schelle	Retainer	Abrazadera
	4008919	2	Molla richiamo	Ressort	Feder	Spring	Muelle
	4046516	2	Guarnizione	Joint	Dichtung	Gasket	Junta
	4067417	1	Leva d	Levier	Hebel	Lever	Palanca
	4067418	1	Leva s	Levier	Hebel	Lever	Palanca
	4069375	2	Anello elastico	Revêtement	Manschette	Lining	Guarnición
	4069396	2	Puntone compl.	Biellette	Druckstange	Pushrod	Biela
	4104000	2	Perno	Axe	Bolzen	Pin	Eje
	4104877	1	Supporto	Support	Lager	Support	Soporte
	4104879	1	Guarnizione	Joint	Dichtung	Gasket	Junta
	4104937	1	Leva compl.	Levier	Hebel	Lever	Palanca
	4104964	1	Fune	Câble	Seil	Cable	Cable
	4119397	1	Bottone	Bouton	Knopf	Button	Botón
	4119398	1	Guarnizione	Joint	Dichtung	Gasket	Junta
	4119399	1	Rosetta	Rondelle	Scheibe	Washer	Arandela
	4162944	1	Carrucola	Poulie	Seilrolle	Sheave	Roldana
	10519301	4	Rosetta piana	Rondelle	Scheibe	Washer	Arandela
	10519601	4	Rosetta piana	Rondelle	Scheibe	Washer	Arandela
	10734201	1	Copiglia spaccata	Goupille	Splint	Pin	Pasador abierto
	10788811	4	Dado	Écrou	Mutter	Nut	Tuerca
	10796301	4	Copiglia spaccata	Goupille	Splint	Pin	Pasador abierto
	10977621	4	Vite	Vis	Schraube	Screw	Tornillo
	12605270	4	Rosetta dentata	Rondelle frein	Sicherungsring	Lockwasher	Arandela dentada
	12642701	4	Rosetta piana	Rondelle	Scheibe	Washer	Arandela
	13400775	2	Anello sicurezza	Arrêtoir	Sicherungsring	Lockring	Anillo elástico
	13550301	1	Rosetta piana	Rondelle	Scheibe	Washer	Arandela
	13825711	4	Vite	Vis	Schraube	Screw	Tornillo

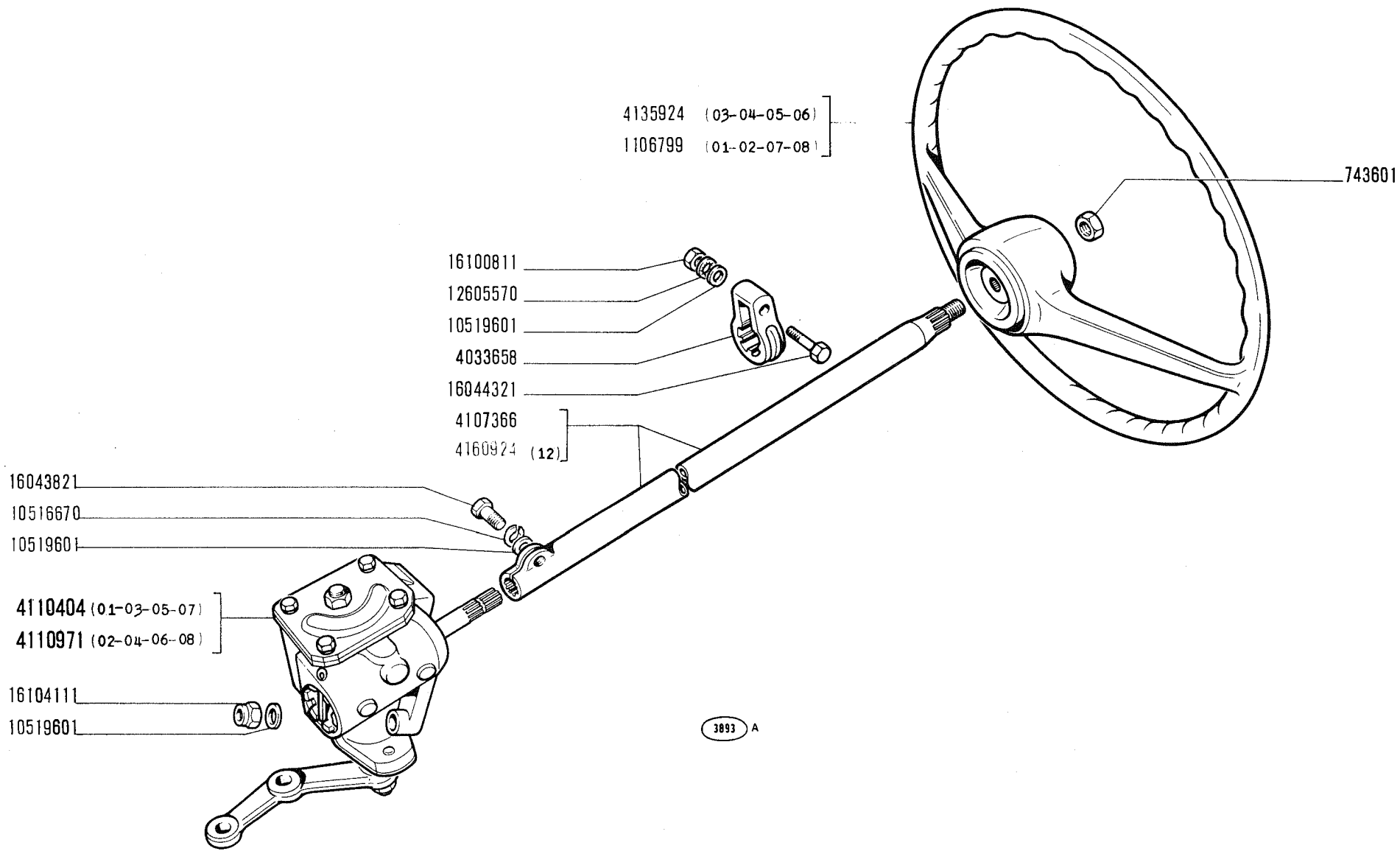

modif.	n. ordinaz.	quant.	Denominazione	Désignation	Benennung	Description	Denominaciones
	743601	1	Dado	Écrou	Mutter	Nut	Tuerca
	1106799	1	Volante - 01 - 02 - 07 - 08 -	Volant	Lenkrad	Steering wheel	Volante
	4033658	1	Supporto	Support	Lager	Support	Soporte
	4107366	1	Albero	Arbre	Welle	Shaft	Árbol
	4110404	1	Scatola sterzo compl. - 01 - 03 - 05 - 07 -	Boîtier de direction	Lenkgehäuse	Steering box	Caja de dirección
	4110971	1	Scatola sterzo compl. - 02 - 04 - 06 - 08 -	Boîtier de direction	Lenkgehäuse	Steering box	Caja de dirección
	4135924	1	Volante - 03 - 04 - 05 - 06 -	Volant	Lenkrad	Steering wheel	Volante
	4160924	1	Albero - 12 -	Arbre	Welle	Shaft	Árbol
	10516670	1	Rosetta elastica	Rondelle frein	Sicherungsring	Lockwasher	Arandela elástica
	10519601	6	Rosetta piana	Rondelle	Scheibe	Washer	Arandela
	12605570	1	Rosetta dentata	Rondelle frein	Sicherungsring	Lockwasher	Arandela dentada
	16043821	1	Vite	Vis	Schraube	Screw	Tornillo
	16044321	1	Vite	Vis	Schraube	Screw	Tornillo
	16100811	1	Dado	Écrou	Mutter	Nut	Tuerca
	16104111	3	Dado	Écrou	Mutter	Nut	Tuerca

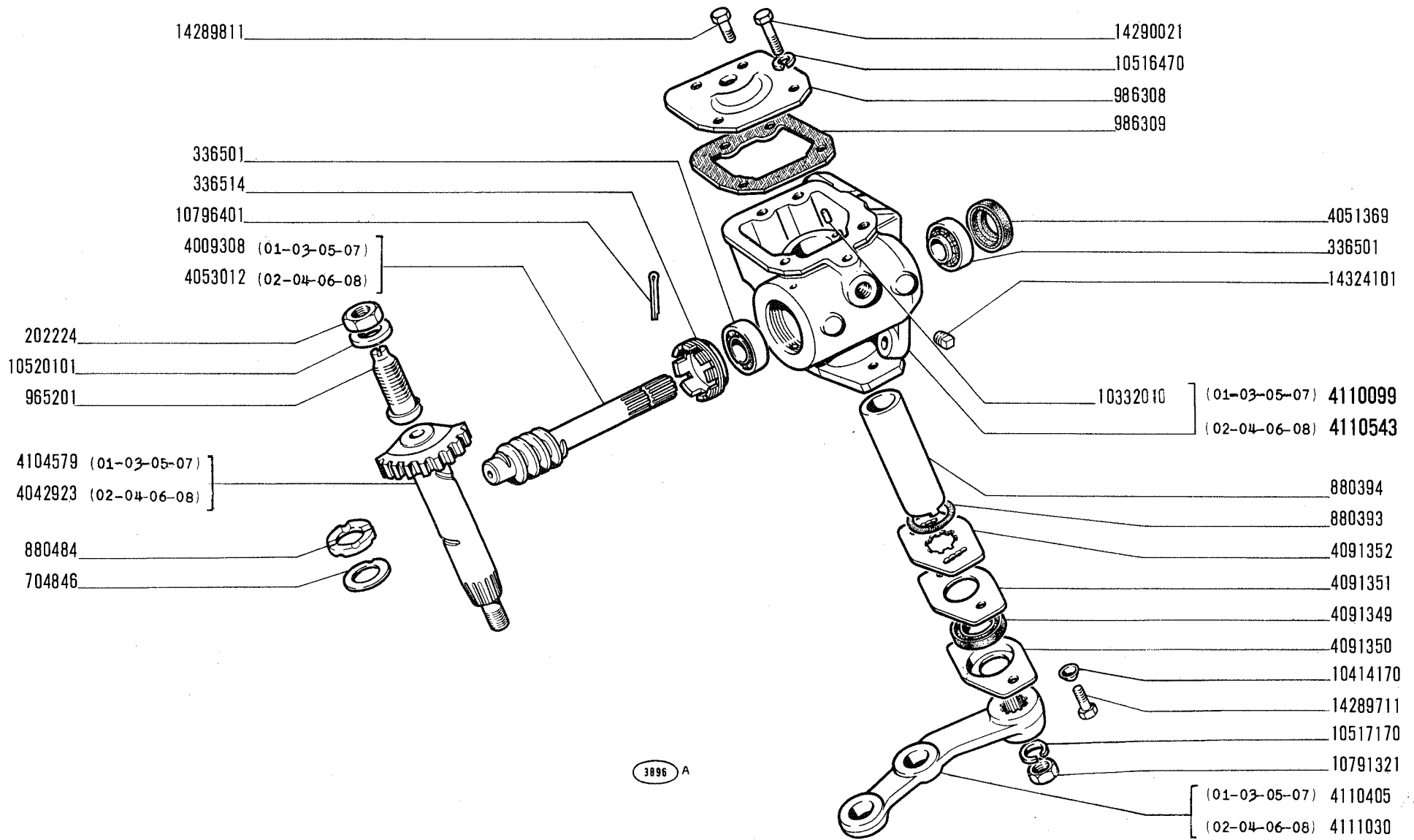

modif.	n. ordinaz.	quant.	Denominazione	Désignation	Benennung	Description	Denominaciones
	202224	1	Dado	Écrou	Mutter	Nut	Tuerca
	336501	2	Cuscinetto rulli	Roulement	Lager	Bearing	Rodamiento
	336514	1	Ghiera inf.	Écrou	Gewinding	Slotted ring	Tornillo
	704846	1	Anello registro	Bague	Ring	Ring	Anillo
	880393	1	Guarnizione sup.	Joint	Dichtring	Seal	Junta
	880394	1	Boccola	Douille	Büchse	Bush	Casquillo
	880484	1	Rondella rasamento	Rondelle	Scheibe	Washer	Arandela
	965201	1	Vite registro	Vis	Schraube	Screw	Tornillo
	986308	1	Coperchio	Couvercle	Deckel	Cover	Tapa
	986309	1	Guarnizione	Joint	Dichtung	Gasket	Junta
	4009308	1	Vite perpetua - 01 - 03 - 05 - 07 -	Vis sans-fin	Schnecke	Worm screw	Tornillo sin fin
	4042923	1	Settore con albero - 02 - 04 - 06 - 08	Secteur avec arbre	Zahnbogen m. Welle	Sector w/shaft	Rueda con eje
	4051369	1	Guarnizione sup.	Joint	Dichtring	Seal	Junta
	4053012	1	Vite perpetua - 02 - 04 - 06 - 08	Vis sans-fin	Schnecke	Worm screw	Tornillo sin fin
	4091349	1	Guarnizione inf.	Joint	Dichtring	Seal	Junta
	4091350	1	Coperchio	Couvercle	Deckel	Cover	Tapa
	4091351	1	Guarnizione	Joint	Dichtung	Gasket	Junta
	4091352	1	Piastrina	Plaquette	Plättchen	Plate	Placa
	4104579	1	Settore con albero - 01 - 03 - 05 - 07 -	Secteur avec arbre	Zahnbogen m. Welle	Sector w/shaft	Rueda con eje
	4110099	1	Scatola compl. - 01 - 03 - 05 - 07 -	Carter	Gehäuse	Case	Caja
	4110405	1	Leva - 01 - 03 - 05 - 07 -	Levier	Hebel	Lever	Palanca
	4110543	1	Scatola compl. - 02 - 04 - 06 - 08 -	Carter	Gehäuse	Case	Caja
	4111030	1	Leva - 02 - 04 - - 06 - 08 -	Levier	Hebel	Lever	Palanca
	10332010	1	Grano	Ergot	Passtift	Dowel	Pitón
	10414170	1	Rosetta elastica	Rondelle frein	Sicherungsring	Lockwasher	Arandela elástica
	10516470	4	Rosetta elastica	Rondelle frein	Sicherungsring	Lockwasher	Arandela elástica
	10517170	1	Rosetta elastica	Rondelle frein	Sicherungsring	Lockwasher	Arandela elástica
	10520101	1	Rosetta piana	Rondelle	Scheibe	Washer	Arandela
	10791321	1	Dado	Écrou	Mutter	Nut	Tuerca
	10796401	1	Copiglia spaccata	Goupille	Splint	Pin	Pasador abierto
	14289711	2	Vite	Vis	Schraube	Screw	Tornillo
	14289811	2	Vite corta	Vis	Schraube	Screw	Tornillo
	14290021	2	Vite lunga	Vis	Schraube	Screw	Tornillo
	14324101	1	Tappo	Bouchon	Stopfen	Plug	Tapón

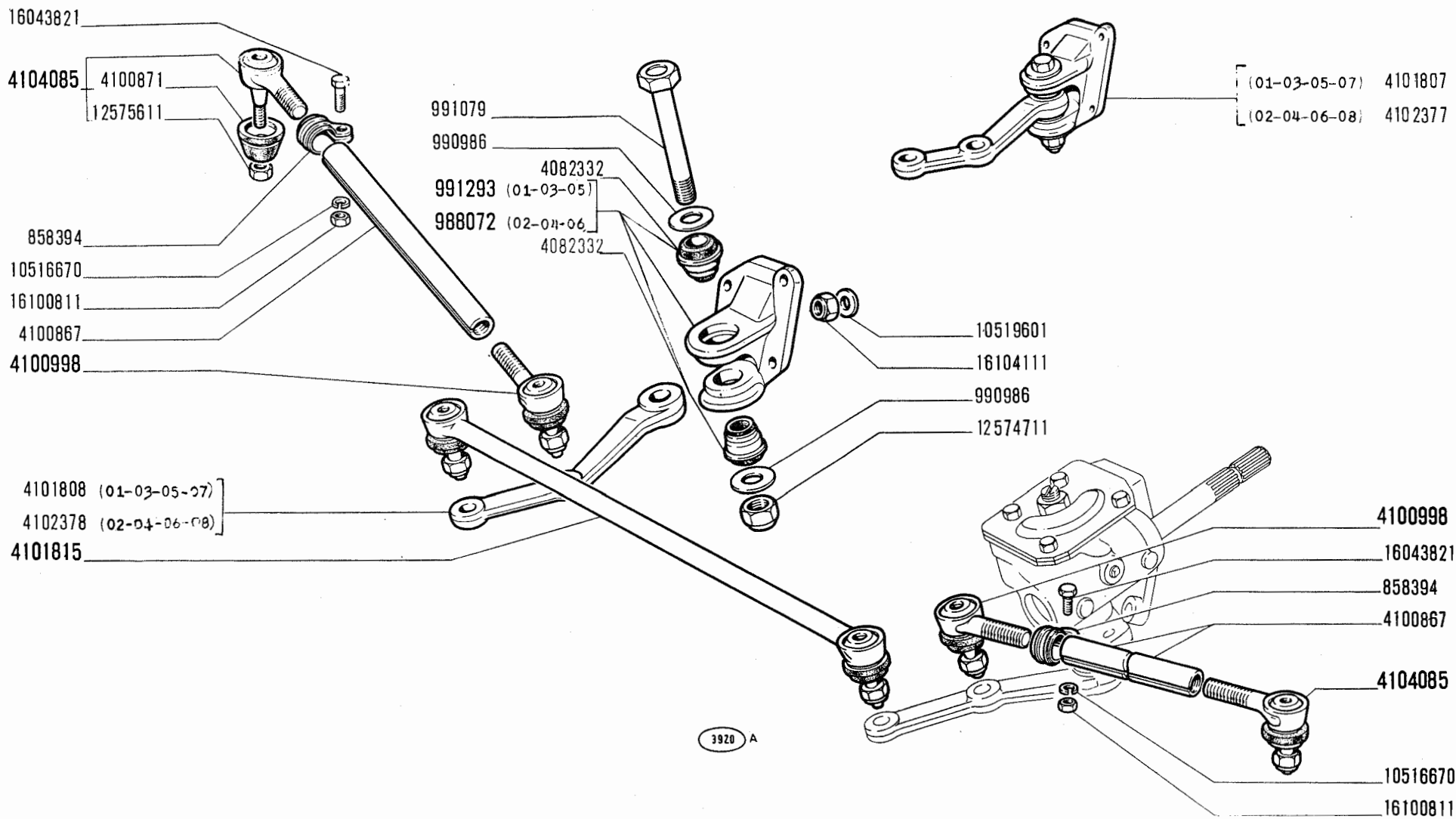

TIRANTERIA COMANDO STERZO

- Timonerie de direction
- Lenkgestänge

- Steering Linkage
- Timonerla de la direccíon

modif.	n. ordinaz.	quant.	Denominazione	Désignation	Benennung	Description	Denominaciones
	858394	4	Morsetto	Collier	Klemme	Clamp	Collar
	988072	1	Supporto compl. - 02 - 04 - 06 - 08 -	Support	Lager	Support	Soporte
	990986	2	Rosetta piana	Rondelle	Scheibe	Washer	Arandela
	991079	1	Perno	Axe	Bolzen	Pin	Eje
	991293	1	Supporto compl. - 01 - 03 - 05 - 07 -	Support	Lager	Support	Soporte
	4082332	2	Boccola elastica	Bague élastique	Elastische Büchse	Resilient bush	Casquillo elástico
	4100867	2	Tirante	Barre	Lenkstange	Rod	Barra de acoplamiento
	4100871	6	Cuffia	Capuchon	Manschette	Boot	Capuchón
	4100998	2	Testa centr. compl.	Joint à rotule	Stangenkopf	Head	Articulación
	4101807	1	Supporto compl. - 01 - 03 - 05 - 07 -	Support	Lager	Support	Soporte
	4101808	1	Leva rinvio - 01 - 03 - 05 - 07 -	Levier	Hebel	Lever	Palanca
	4101815	1	Tirante compl.	Barre	Lenkstange	Rod	Biela transversal
	4102377	1	Supporto compl. - 02 - 04 - 06 - 08 -	Support	Lager	Support	Soporte
	4102378	1	Leva rinvio - 02 - 04 - 06 - 08 -	Levier	Hebel	Lever	Palanca
	4104085	2	Testa lat. compl.	Joint à rotule	Stangenkopf	Head	Articulación
	10516670	4	Rosetta elastica	Rondelle frein	Sicherungsring	Lockwasher	Arandela elástica
	10519601	3	Rosetta piana	Rondelle	Scheibe	Washer	Arandela
	12574711	1	Dado	Écrou	Mutter	Nut	Tuerca
	12575611	6	Dado	Écrou	Mutter	Nut	Tuerca
	16043821	4	Vite	Vis	Schraube	Screw	Tornillo
	16100811	4	Dado	Écrou	Mutter	Nut	Tuerca
	16104111	3	Dado	Écrou	Mutter	Nut	Tuerca

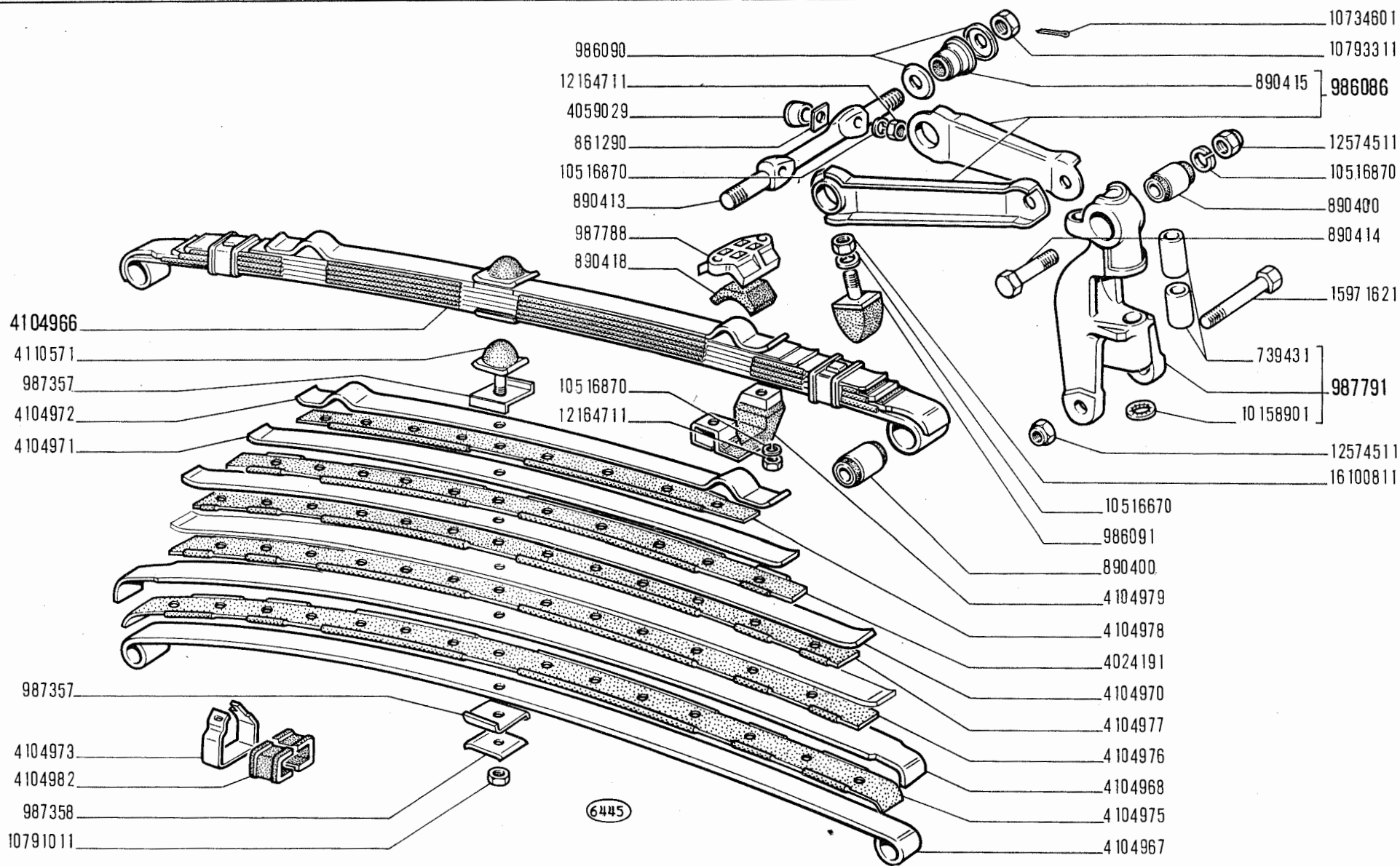

modif.	n. ordinaz.	quant.	Denominazione	Désignation	Benennung	Description	Denominaciones
	739431	4	Boccola	Douille	Büchse	Bush	Casquillo
	861290	—	Piastrina	Plaquette	Plättchen	Plate	Placa
	890400	4	Estendbloc	Estendbloc	Estendbloc	Estendbloc	Estendbloc
	890413	2	Perno	Axe	Bolzen	Pin	Eje
	890414	2	Perno sup.	Axe	Bolzen	Pin	Pasador
	890415	4	Boccola	Douille	Büchse	Bush	Casquillo
	890418	2	Tassello elastico	Tampon	Gummistück	Pad	Almohadilla
	986086	4	Sembraccio compl.	Bras	Lenker	Arm	Brazo
	986090	8	Scodellino	Cuvette	Tellerscheibe	Cup	Platillo
	986091	2	Paracolpi	Pare-chocs	Gummipuffer	Bumper	Tope
	986093	8	Anello elastico	Bague	Ring	Ring	Guarnición
	987357	2	Piastrina	Plaquette	Plättchen	Plate	Placa
	987358	2	Piastra	Plaque	Platte	Plate	Placa
	987788	2	Piastra	Support	Lager	Support	Soporte
	987789	4	Scodellino inf.	Cuvette	Tellerscheibe	Cup	Platillo
	987791	2	Supporto compl.	Support	Lager	Support	Soporte
	4024191	1	Spessore elastico	Cale élastique	Elast. Unterlage	Liner	Suplemento
	4048307	2	Ammortizzatore compl.	Amortisseur	Stossdämpfer	Shock absorber	Amortiguador
	4059029	4	Distanziale	Entretoise	Abstandstück	Spacer	Separador
	4104966	1	Balestra compl.	Ressort à lames	Blattfeder	Leaf spring	Ballesta
	4104967	1	Lama maestra	Lame	Federblatt	Leaf	Hoja
	4104968	1	Seconda lama	Lame	Federblatt	Leaf	Hoja
	4104970	1	Quarta lama	Lame	Federblatt	Leaf	Hoja
	4104971	1	Quinta lama	Lame	Federblatt	Leaf	Hoja
	4104972	1	Sesta lama	Lame	Federblatt	Leaf	Hoja
	4104973	2	Staffetta	Collier	Schelle	Retainer	Abrazadera
	4104975	1	Spessore elastico	Cale élastique	Elast. Unterlage	Liner	Suplemento
	4104976	1	Spessore elastico	Cale élastique	Elast. Unterlage	Liner	Suplemento
	4104977	1	Spessore elastico	Cale élastique	Elast. Unterlage	Liner	Suplemento
	4104978	1	Spessore elastico	Cale élastique	Elast. Unterlage	Liner	Suplemento
	4104979	2	Supporto elastico	Support	Lager	Support	Soporte
	4104982	4	Fascia elastica	Cale élastique	Elast. Unterlage	Liner	Suplemento
	4110571	1	Paracolpi	Pare-chocs	Gummipuffer	Bumper	Tope
	5000897	4	Rosetta piana	Rondelle	Scheibe	Washer	Arandela

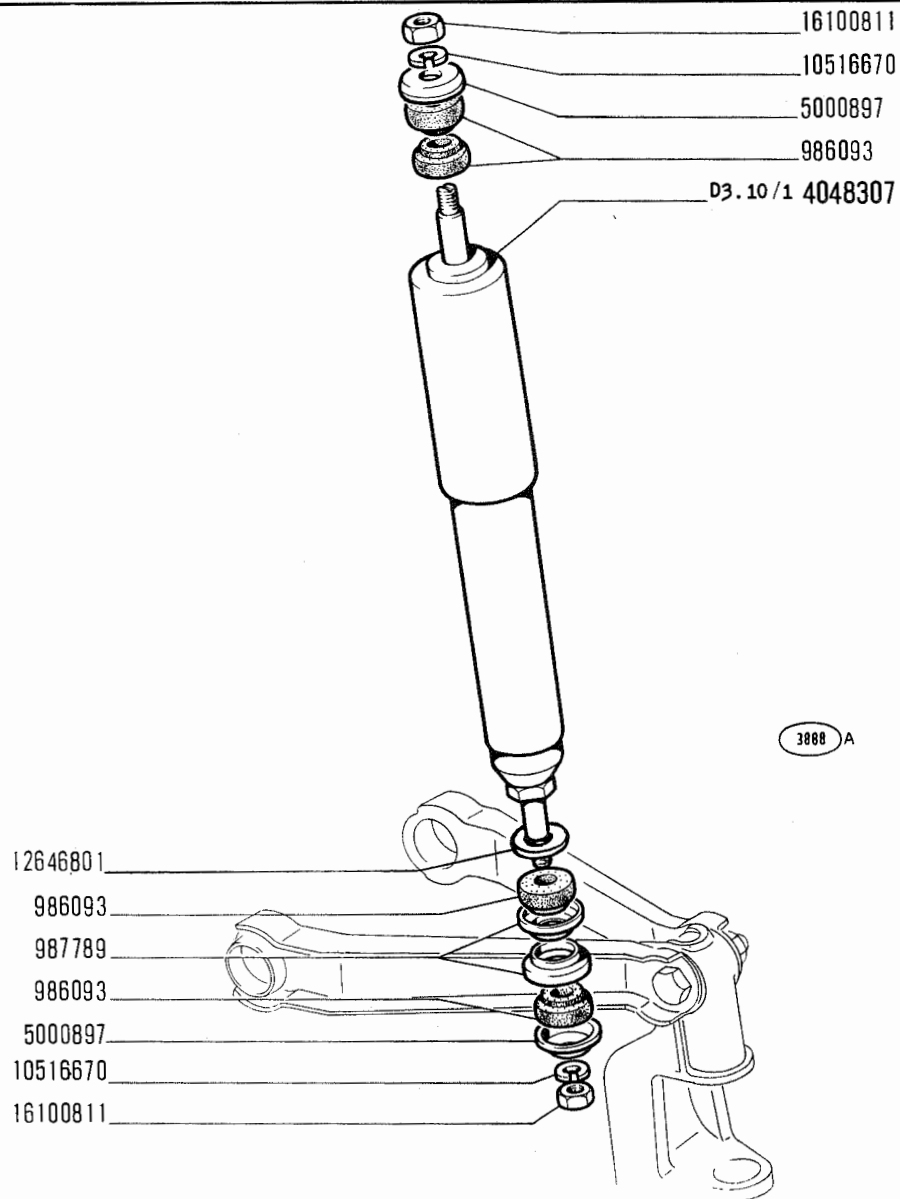

blanchina
panoramica
e derivati

SOSPENSIONE ANTERIORE

- Suspension AV
- Vorderradaufhängung

- Front Suspension
- Suspensión anterior

D3.01

2/2

modif.	n. ordinaz.	quant.	Denominazione	Désignation	Benennung	Description	Denominaciones
	10158901	2	Tappo	Bouchon	Stopfen	Plug	Tapón
	10516670	6	Rosetta elastica	Rondelle frein	Sicherungsring	Lockwasher	Arandela elástica
	10516870	10	Rosetta elastica	Rondelle frein	Sicherungsring	Lockwasher	Arandela elástica
	10734601	4	Copiglia spaccata	Goupille	Splint	Pin	Pasador abierto
	10791011	1	Dado	Écrou	Mutter	Nut	Tuerca
	10793311	4	Dado	Écrou	Mutter	Nut	Tuerca
	12164711	8	Dado	Écrou	Mutter	Nut	Tuerca
	12574511	4	Dado	Écrou	Mutter	Nut	Tuerca
	12646801	2	Rosetta piana	Rondelle	Scheibe	Washer	Arandela
	15971621	2	Vite inf.	Vis	Schraube	Screw	Tornillo
	16100811	6	Dado	Écrou	Mutter	Nut	Tuerca
	901083	5	Perni e boccole	Axes et douilles	Bolzen u. Büchsen	Pins and bushes	Ejes y casquillos

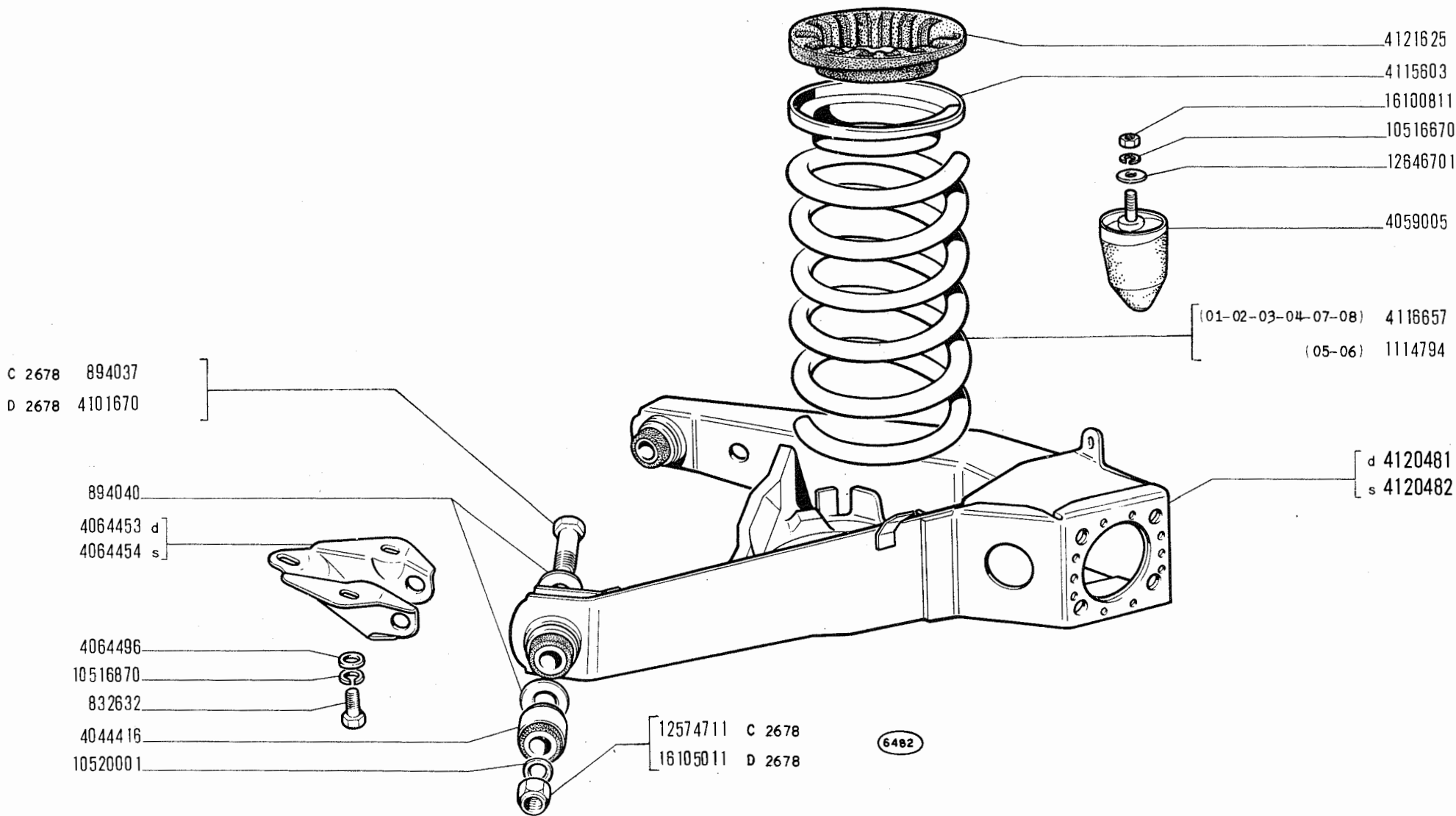

bianchina
panoramica
 e derivati

SOSPENSIONE POSTERIORE

- Suspension AR
- Hinterradaufhängung

- Rear Suspension
- Suspensión posterior

D3.05

1/2

modif.	n. ordinaz.	quant.	Denominazione	Désignation	Benennung	Description	Denominaciones
	832632	6	Vite	Vis	Schraube	Screw	Tornillo
	849128	8	Anello elastico	Bague	Ring	Ring	Guarnición
	875605	4	Rosetta inf.	Rondelle	Scheibe	Washer	Arandela
C 2678	894037	4	Perno 12 x 1,5	Axe	Bolzen	Pin	Pasador
	894040	—	Rosetta registro	Rondelle	Scheibe	Washer	Arandela
	1114794	2	Molla - 05 - 06 -	Ressort	Feder	Spring	Resorte
	4044416	4	Estendbloc	Estendbloc	Estendbloc	Estendbloc	Estendbloc
	4059005	2	Paracolpi	Pare-chocs	Gummipuffer	Bumper	Tope
	4059006	2	Ammortizzatore compl.	Amortisseur	Stossdämpfer	Shock absorber	Amortiguador
	4064453	1	Supporto ant. d	Support	Lager	Support	Soporte
	4064454	1	Supporto ant. s	Support	Lager	Support	Soporte
	4064496	6	Rosetta piana	Rondelle	Scheibe	Washer	Arandela
D 2678	4101670	4	Perno 12 x 1,25	Axe	Bolzen	Pin	Pasador
	4115603	2	Scodellino	Cuvette	Tellerscheibe	Cup	Placillo
	4116657	2	Molla - 01 - 02 - 03 - 04 - 07 - 08 -	Ressort	Feder	Spring	Muelle
	4120481	1	Braccio d compl.	Bras	Lenker	Arm	Brazo
	4120482	1	Braccio s compl.	Bras	Lenker	Arm	Brazo
	4121625	2	Anello gomma	Bague	Ring	Ring	Guarnición
	10516670	2	Rosetta elastica	Rondelle frein	Sicherungsring	Lockwasher	Arandela elástica
	10516870	10	Rosetta elastica	Rondelle frein	Sicherungsring	Lockwasher	Arandela elástica
	10520001	4	Rosetta piana	Rondelle	Scheibe	Washer	Arandela
C 2678	12164711	4	Dado	Écrou	Mutter	Nut	Tuerca
	12574711	4	Dado	Écrou	Mutter	Nut	Tuerca
	12644301	4	Rosetta piana	Rondelle	Scheibe	Washer	Arandela
	12646701	2	Rosetta piana	Rondelle	Scheibe	Washer	Arandela
	16100811	2	Dado	Écrou	Mutter	Nut	Tuerca
D 2678	16105011	4	Dado	Écrou	Mutter	Nut	Tuerca
	901084	5	Perni e boccole	Axes et douilles	Bolzen u. Büchsen	Pins and bushes	Ejes y casquillos

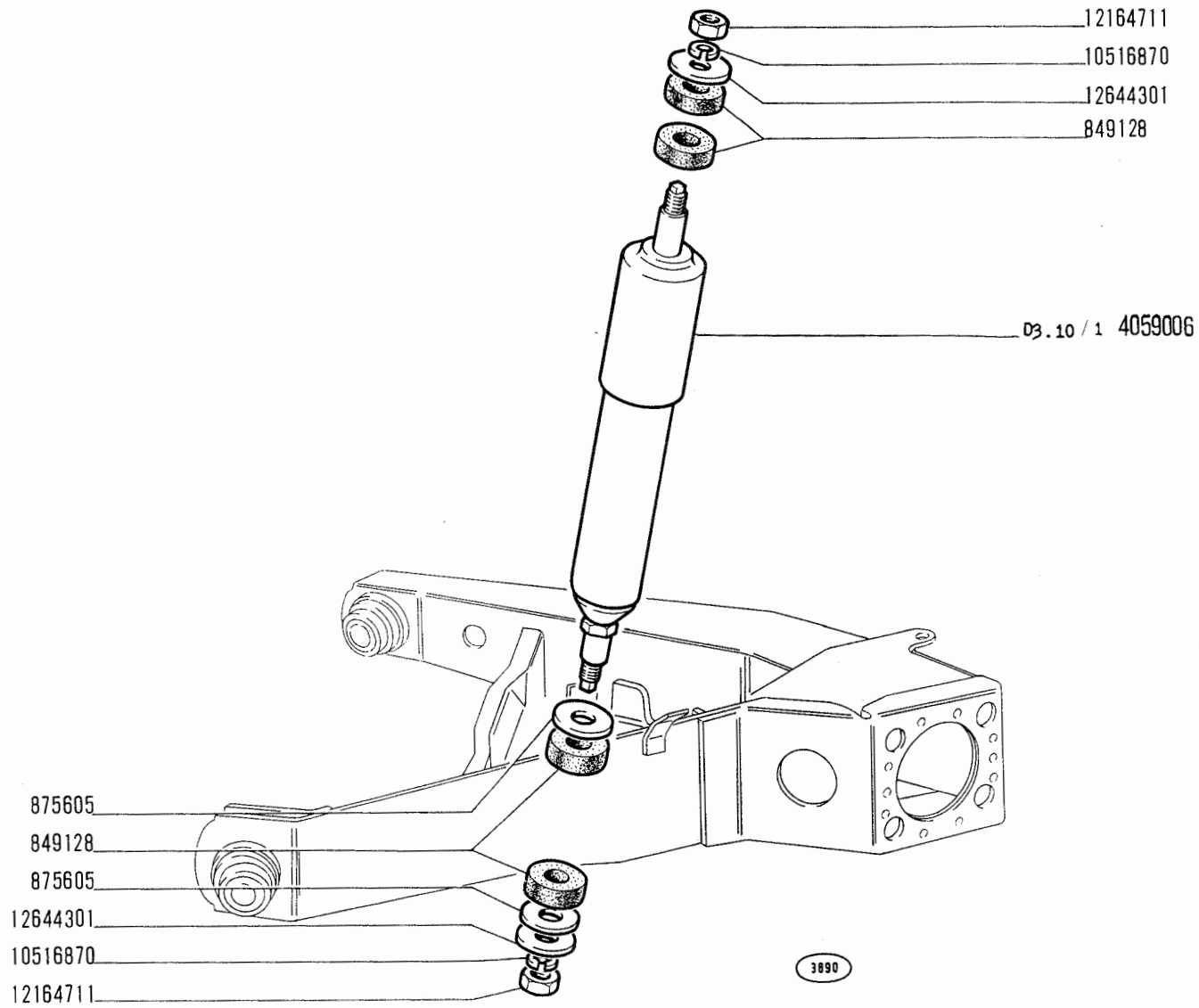

blanchina
panoramica
e derivati

SOSPENSIONE POSTERIORE

- Suspension AR
- Hinterradaufhängung

- Rear Suspension
- Suspensión posterior

D3.05

2/2

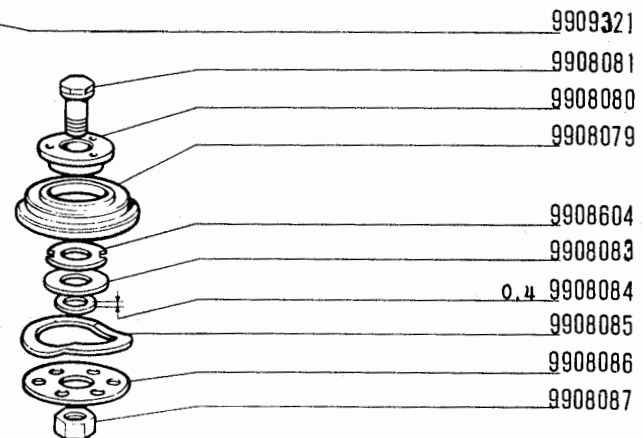
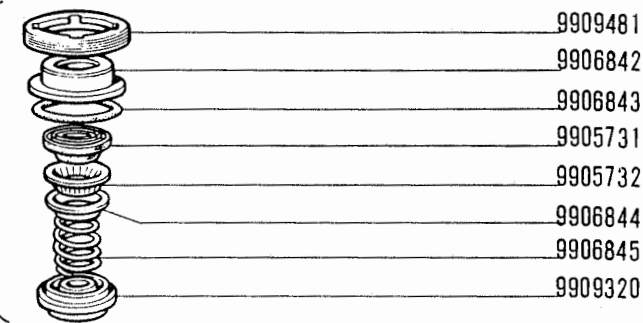
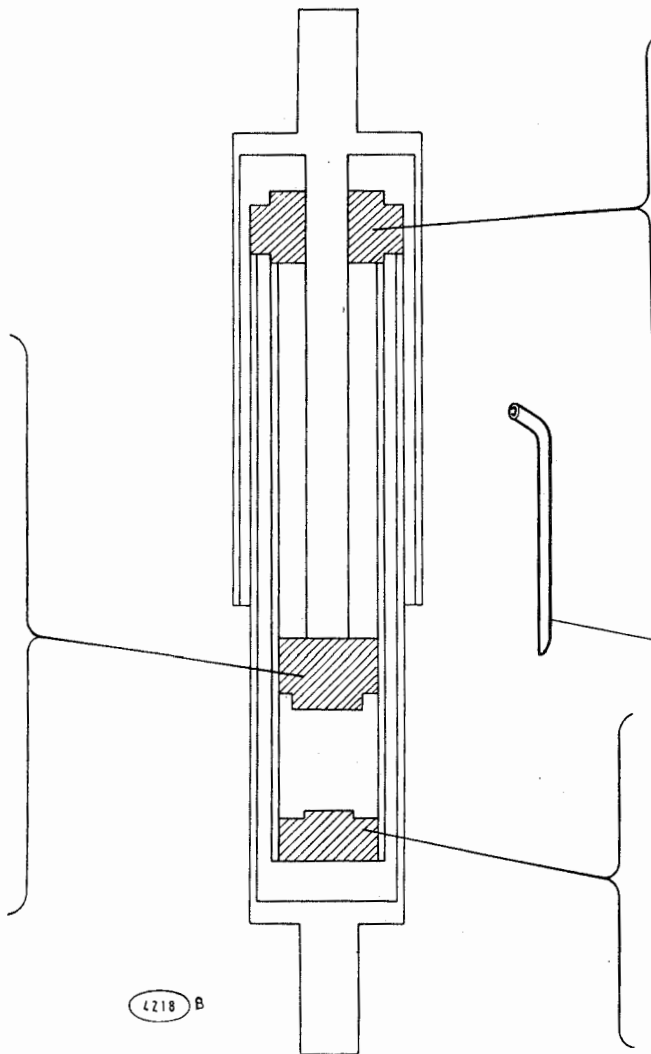
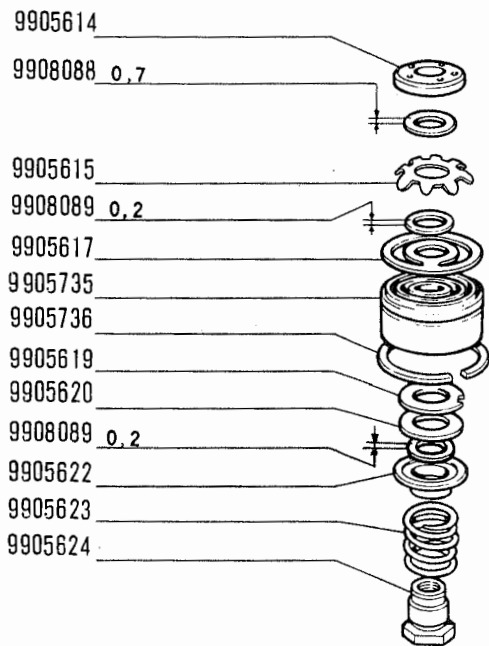

blanchina
panoramica
 e derivati

AMMORTIZZATORE ANTERIORE 4048307 (Riv)

- Amortisseur AV
- Vorderer Stossdämpfer

- Front Shock Absorber
- Amortiguador anterior

D3.10

modif.	n. ordinaz.	quant.	Denominazione	Désignation	Benennung	Description	Denominaciones
9905614	1		Disco	Disque	Scheibe	Plate	Disco
9905615	1		Molla a stella	Ressort	Federscheibe	Spring	Muelle
9905617	1		Valvola	Soupape	Ventil	Valve	Válvula
9905619	1		Disco	Disque	Scheibe	Plate	Disco
9905620	1		Disco	Disque	Scheibe	Plate	Disco
9905622	1		Piattello	Coupelle	Tellerscheibe	Plate	Platillo
9905623	1		Molla	Ressort	Feder	Spring	Muelle
9905624	1		Tappo	Bouchon	Stopfen	Plug	Tapón
9905731	1		Boccola gomma	Bague caoutchouc	Gummibüchse	Rubber bush	Cojinete
9905732	1		Molla a linguette	Ressort	Tellerfeder	Spring	Muelle
9905735	1		Stantuffo	Piston	Kolben	Piston	Émbolo
9905736	1		Anello stantuffo	Segment	Kolbenring	Ring	Aro de émbolo
9906842	1		Scodellino	Cuvette	Tellerscheibe	Cup	Platillo
9906843	1		Anello tenuta	Joint	Dichtring	Seal	Junta
9906844	1		Scodellino	Cuvette	Tellerscheibe	Cup	Platillo
9906845	1		Molla	Ressort	Feder	Spring	Muelle
9908079	1		Fondello	Culot	Bodenteller	Plug	Tapón
9908080	1		Piattello	Coupelle	Tellerscheibe	Plate	Platillo
9908081	1		Vite	Vis	Schraube	Screw	Tornillo
9908083	1		Disco	Disque	Scheibe	Plate	Disco
9908084	1		Rosetta sp. 0,4	Rondelle	Scheibe	Washer	Arandela
9908085	1		Molla	Ressort	Feder	Spring	Muelle
9908086	1		Disco	Disque	Scheibe	Plate	Disco
9908087	1		Dado	Écrou	Mutter	Nut	Tuerca
9908088	1		Rosetta sp. 0,7	Rondelle	Scheibe	Washer	Arandela
9908089	3		Rosetta sp. 0,2	Rondelle	Scheibe	Washer	Arandela
9908604	1		Disco	Disque	Scheibe	Plate	Disco
9909320	1		Boccola guida	Douille	Büchse	Bushing	Guía
9909321	1		Tubetto	Tuyau	Rohr	Pipe	Tubo
9909481	1		Ghiera	Écrou	Gewinding	Ring nut	Tornillo

- 9905614
- 9908089 0,2
- 9905615
- 9908088 0,7
- 9905617
- 9905735
- 9905736
- 9905619
- 9905634
- 9905628
- 9905621 0,2
- 9905622
- 9910431
- 9905624

6415

- 9909481
- 9906842
- 9906843
- 9905731
- 9905732
- 9906844
- 9906845
- 9909320

- 9909479
- 9908081
- 9908080
- 9908079
- 9908604
- 9908083
- 0,4 9908084
- 9908085
- 9908086
- 9908087

blanchina
panoramica
e derivati

AMMORTIZZATORE POSTERIORE 4059006 (Riv)

- Amortisseur AR
- Hinterer Stossdämpfer

- Rear Shock Absorber
- Amortiguador posterior

D3.10/1

modif.	n. ordinaz.	quant.	Denominazione	Désignation	Benennung	Description	Denominaciones
	9905614	1	Disco	Disque	Scheibe	Plate	Disco
	9905615	1	Molla a stella	Ressort	Federscheibe	Spring	Muelle
	9905617	1	Valvola	Soupape	Ventil	Valve	Válvula
	9905619	1	Disco	Disque	Scheibe	Plate	Disco
	9905621	1	Rosetta piana sp. 0,2	Rondelle	Scheibe	Washer	Arandela
	9905622	1	Piattello	Coupelle	Tellerscheibe	Plate	Platillo
	9905624	1	Tappo	Bouchon	Stopfen	Plug	Tapón
	9905628	1	Disco	Disque	Scheibe	Plate	Disco
	9905634	1	Disco	Disque	Scheibe	Plate	Disco
	9905731	1	Boccola gomma	Bague caoutchouc	Gummibüchse	Rubber bush	Cojinete
	9905732	1	Molla a linguette	Ressort	Tellerfeder	Spring	Muelle
	9905735	1	Stantuffo	Piston	Kolben	Piston	Émbolo
	9905736	1	Anello sicurezza	Arrêtoir	Sicherungsring	Lockring	Anillo de freno
	9906842	1	Scodellino	Cuvette	Tellerscheibe	Cup	Platillo
	9906843	1	Anello tenuta	Joint	Dichtring	Seal	Junta
	9906844	1	Scodellino	Cuvette	Tellerscheibe	Cup	Platillo
	9906845	1	Molla	Ressort	Feder	Spring	Muelle
	9908079	1	Fondello	Culot	Bodenteller	Plug	Tapón
	9908080	1	Piattello	Coupelle	Tellerscheibe	Plate	Platillo
	9908081	1	Vite	Vis	Schraube	Screw	Tornillo
	9908083	1	Disco	Disque	Scheibe	Plate	Disco
	9908084	1	Rosetta piana sp. 0,4	Rondelle	Scheibe	Washer	Arandela
	9908085	1	Molla	Ressort	Feder	Spring	Muelle
	9908086	1	Disco	Disque	Scheibe	Plate	Disco
	9908087	1	Dado	Écrou	Mutter	Nut	Tuerca
	9908088	1	Rosetta piana sp. 0,7	Rondelle	Scheibe	Washer	Arandela
	9908089	2	Rosetta piana sp. 0,2	Rondelle	Scheibe	Washer	Arandela
	9908604	1	Disco	Disque	Scheibe	Plate	Disco
	9909320	1	Boccola guida	Douille	Büchse	Bushing	Guía
	9909479	1	Tubetto	Tuyau	Rohr	Pipe	Tubo
	9909481	1	Ghiera	Écrou	Gewinding	Ring nut	Tornillo
	9910431	1	Molla	Ressort	Feder	Spring	Muelle

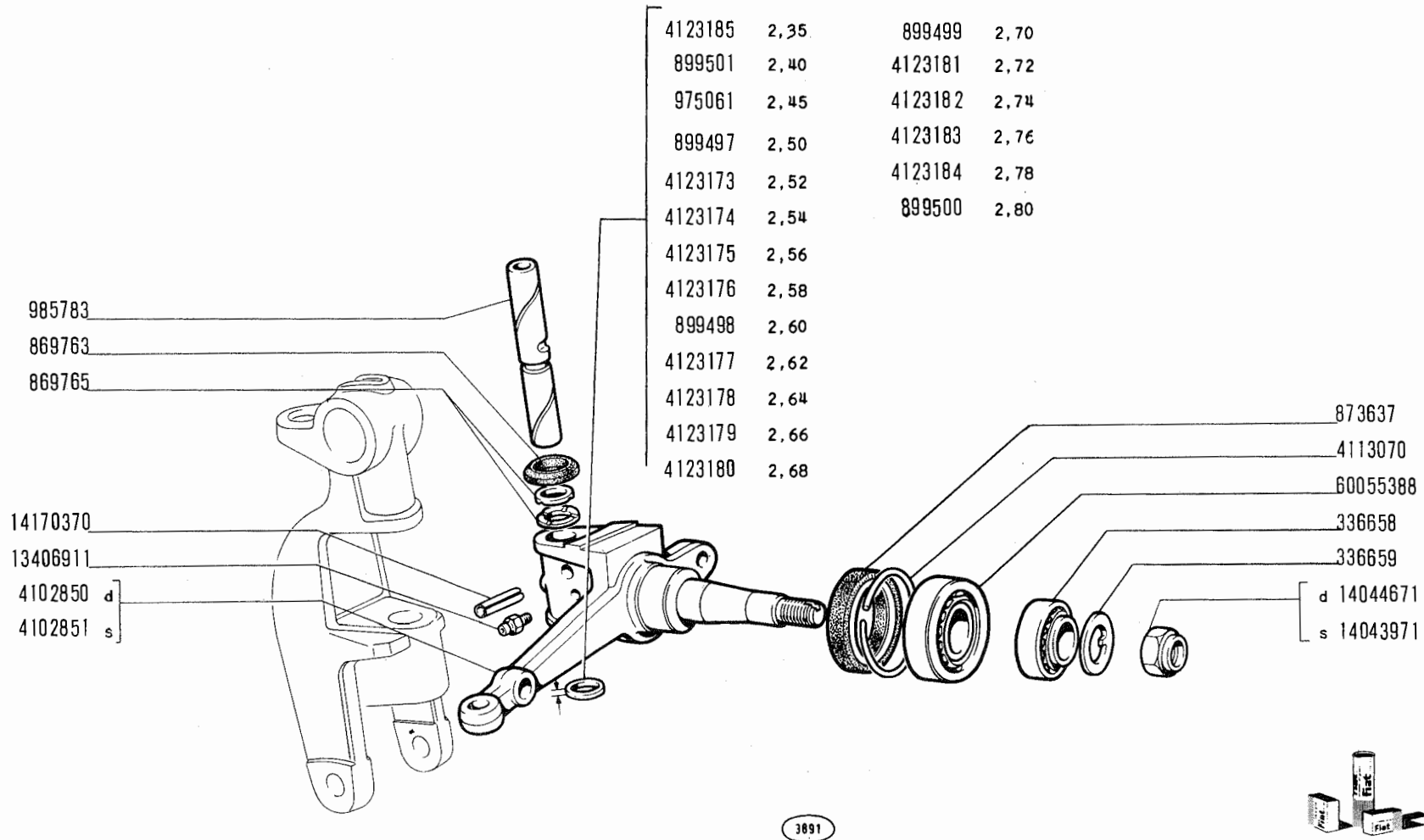

modif.	n. ordinaz.	quant.	Denominazione	Désignation	Benennung	Description	Denominaciones
	336658	2	Cuscinetto a rulli	Roulement	Lager	Bearing	Rodamiento
	336659	2	Rondella	Rondelle	Scheibe	Washer	Arandela
	869763	2	Anello gomma	Bague	Ring	Thrust ring	Anillo de goma
	869765	4	Anello reggispinta	Bague	Ring	Thrust ring	Anillo de apoyo
	873637	2	Guarnizione	Joint	Dichtring	Seal	Junta
	899497	2	Anello sp. 2,50	Bague	Ring	Shim	Anillo
	899498	2	Anello sp. 2,60	Bague	Ring	Shim	Anillo
	899499	2	Anello sp. 2,70	Bague	Ring	Shim	Anillo
	899500	2	Anello sp. 2,80	Bague	Ring	Shim	Anillo
	899501	2	Anello sp. 2,40	Bague	Ring	Shim	Anillo
	975061	2	Anello sp. 2,45	Bague	Ring	Shim	Anillo
	985783	2	Perno	Axe	Bolzen	Pin	Anillo
	4102850	1	Fuso a snodo d	Fusée	Achsschenkel	Knuckle	Mangueta
	4102851	1	Fuso a snodo s	Fusée	Achsschenkel	Knuckle	Mangueta
	4113070	2	Anello	Bague	Ring	Shim	Anillo
	4123173	2	Anello sp. 2,52	Bague	Ring	Shim	Anillo
	4123174	2	Anello sp. 2,54	Bague	Ring	Shim	Anillo
	4123175	2	Anello sp. 2,56	Bague	Ring	Shim	Anillo
	4123176	2	Anello sp. 2,58	Bague	Ring	Shim	Anillo
	4123177	2	Anello sp. 2,62	Bague	Ring	Shim	Anillo
	4123178	2	Anello sp. 2,64	Bague	Ring	Shim	Anillo
	4123179	2	Anello sp. 2,66	Bague	Ring	Shim	Anillo
	4123180	2	Anello sp. 2,68	Bague	Ring	Shim	Anillo
	4123181	2	Anello sp. 2,72	Bague	Ring	Shim	Anillo
	4123182	2	Anello sp. 2,74	Bague	Ring	Shim	Anillo
	4123183	2	Anello sp. 2,76	Bague	Ring	Shim	Anillo
	4123184	2	Anello sp. 2,78	Bague	Ring	Shim	Anillo
	4123185	2	Anello sp. 2,35	Bague	Ring	Shim	Anillo
	13406911	2	Ingrassatore	Graisseur	Schmiernippel	Fitting	Engrasador
	14043971	1	Dado s	Ecrou	Mutter	Nut	Tuerca
	14044671	1	Dado d	Ecrou	Mutter	Nut	Tuerca
	14170370	2	Spina elastica	Goupille	Federstift	Cotter	Chaveta elástica
	60055388	2	Cuscinetto a rulli	Roulement	Lager	Bearing	Rodamiento
	901085	S	Perni e boccole	Axes et bagues	Bolzen u. Büchsen	Pins and bushes	Ejes y casquillos

4080533
814635
1110837

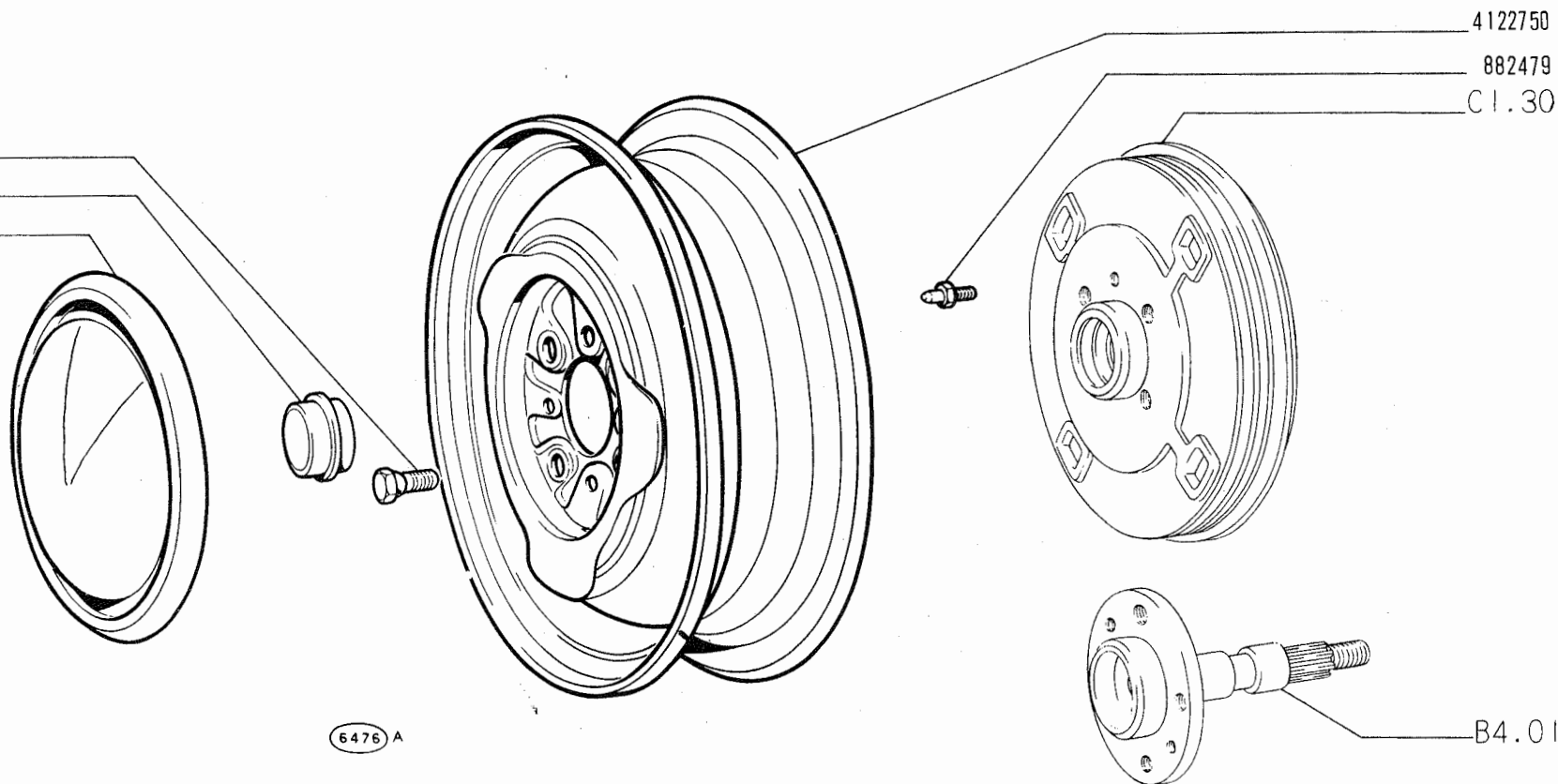

bianchina
panoramica
e derivati

- Roues
- Räder

RUOTE

- Wheels
- Ruedas

D3.16

modif.	n. ordinaz.	quant.	Denominazione	Désignation	Benennung	Description	Denominaciones
	814635	2	Coppa mozzo	Chapeau	Nabendeckel	Cup	Tapacubo
	882479	4	Colonna	Vis	Schraube	Screw	Tornillo
	1110837	4	Coppa ruota	Enjoliveur	Radkappe	Cap	Embellecedor
	4080533	16	Colonna	Vis	Schraube	Screw	Tornillo
	4122750	5	Ruota	Roue	Rad	Wheel	Rueda

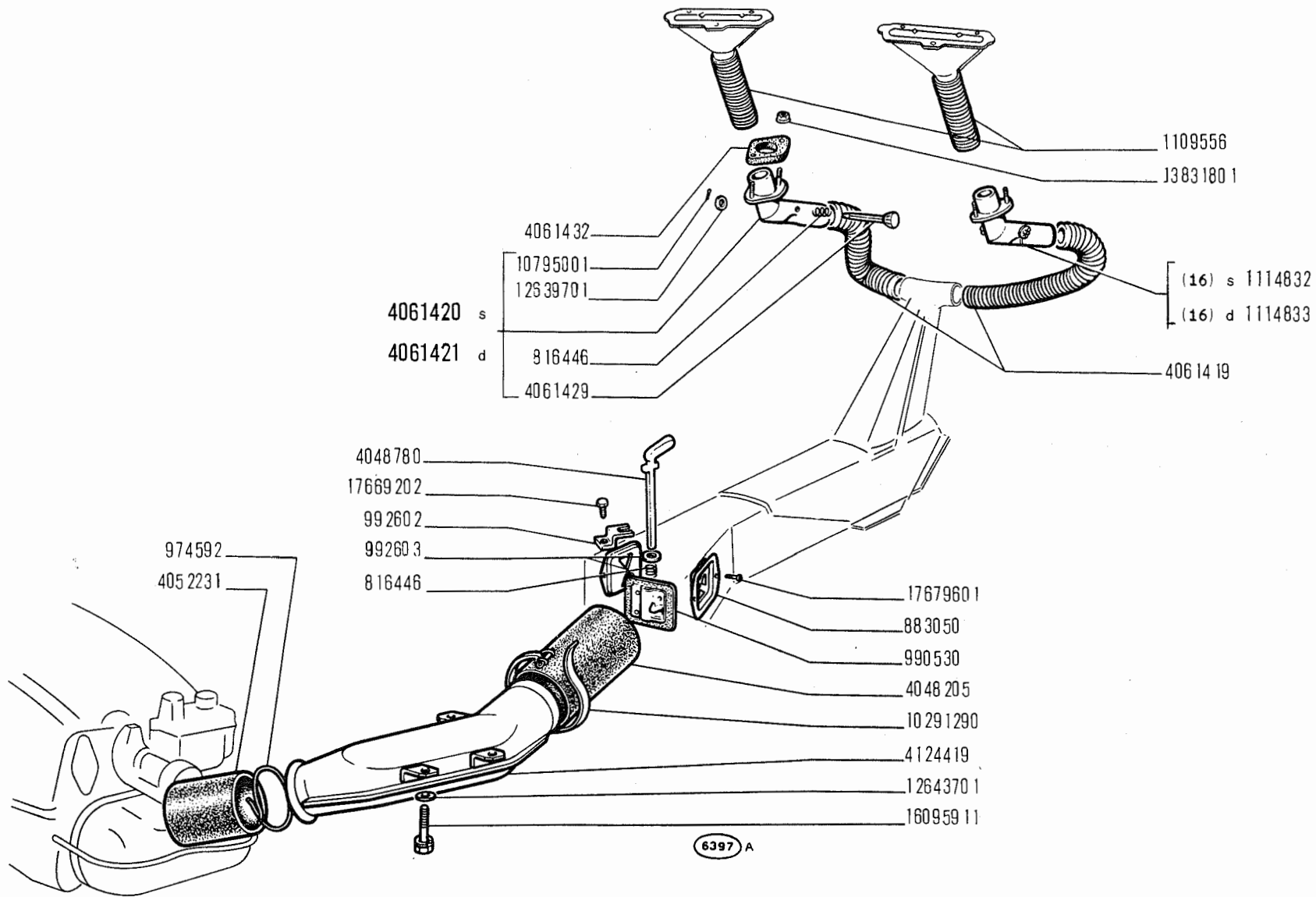

**blanchina
panoramica**

RISCALDAMENTO ARIA

- *Système de chauffage*
- *Luftheizungsanlage*

- *Heating Equipment*
- *Sistema de calefacción*

E1.01

modif.	n. ordinaz.	quant.	Denominazione	Désignation	Benennung	Description	Denominaciones
	816446	3	Molla	Ressort	Feder	Spring	Muelle
	883050	2	Farfalla	Papillon	Drosselklappe	Throttle	Mariposa
	974592	2	Collare	Collier	Schelle	Collar	Abrazadera
	990530	1	Farfalla	Papillon	Drosselklappe	Throttle	Mariposa
	992602	1	Piastrina	Plaquette	Plättchen	Plate	Placa
	992603	2	Rosetta piana	Rondelle	Scheibe	Washer	Arandela
	1109556	2	Manicotto sup.	Manchon	Muffe	Sleeve	Manguito
	1114832	1	Raccordo s compl. - 16 -	Coude	Stutzen	Elbow	Codo
	1114833	1	Raccordo d compl. - 16 -	Coude	Stutzen	Elbow	Codo
	4048205	1	Tubo ant.	Tuyau	Schlauch	Hose	Tubo
	4048780	1	Alberino comando	Axe	Welle	Shaft	Eje
	4052231	1	Tubo post.	Tuyau	Schlauch	Hose	Tubo
	4061419	2	Manicotto inf.	Manchon	Muffe	Sleeve	Manga
	4061420	1	Raccordo s compl.	Coude	Kniestück	Elbow	Codo
	4061421	1	Raccordo d compl.	Coude	Kniestück	Elbow	Codo
	4061429	2	Pomello	Bouton	Knebelgriff	Knob	Botón
	4061432	2	Guarnizione	Joint	Dichtung	Gasket	Junta
	4124419	1	Raccordo intermedio	Tuyau	Leitung	Pipe	Tubo
	10291290	2	Collare	Collier	Schelle	Collar	Abrazadera
	10795001	2	Copiglia spaccata	Goupille	Splint	Pin	Pasador abierto
	12639701	2	Rosetta piana	Rondelle	Scheibe	Washer	Arandela
	12643701	3	Rosetta piana	Rondelle	Scheibe	Washer	Arandela
	13831801	4	Dado	Écrou	Mutter	Nut	Tuerca
	16095911	3	Vite	Vis	Schraube	Screw	Tornillo
	17669202	1	Vite	Vis	Schraube	Screw	Tornillo
	17679601	4	Vite	Vis	Schraube	Screw	Tornillo

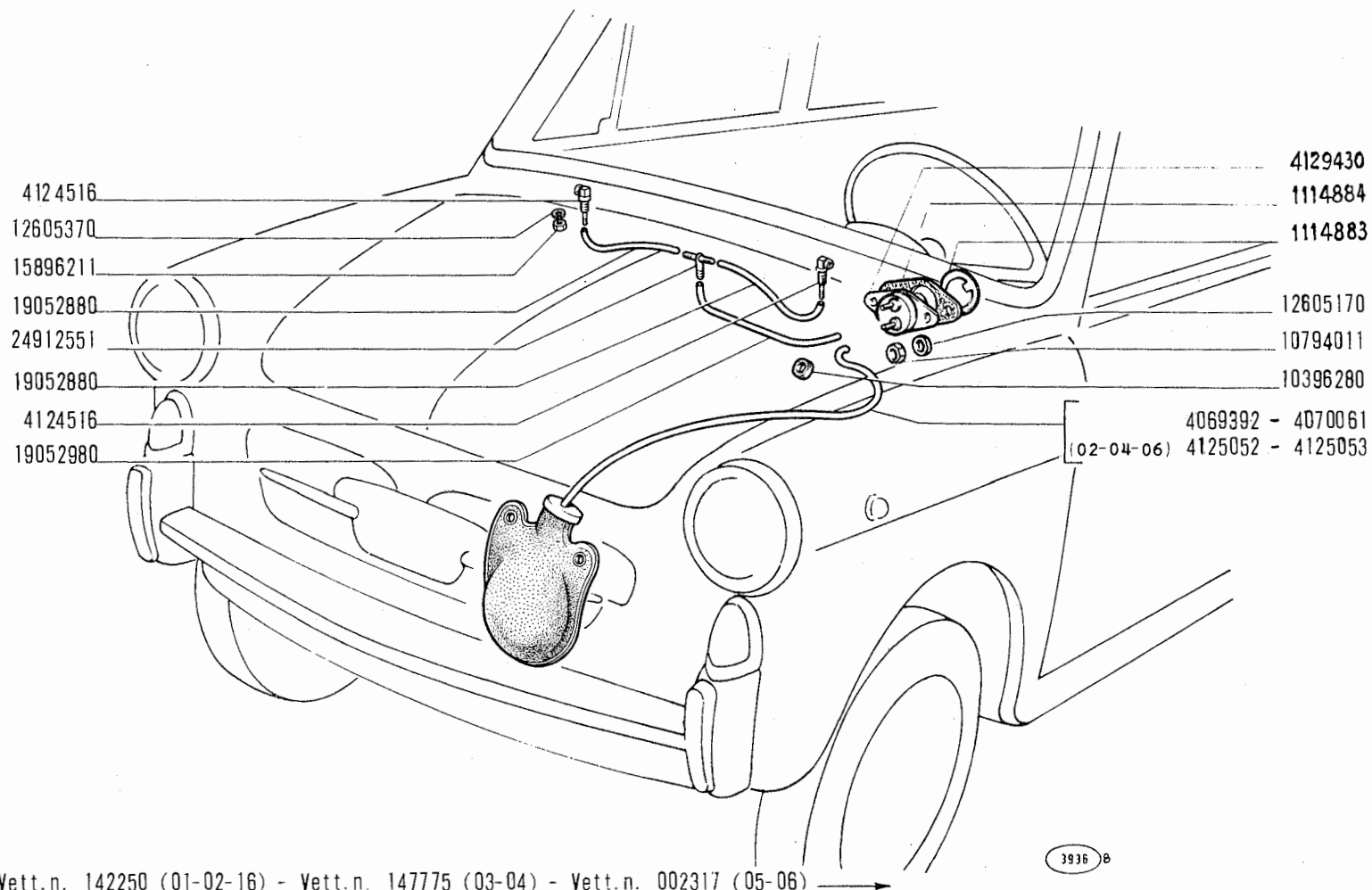

D 4830 Vett.n. 142250 (01-02-16) - Vett.n. 147775 (03-04) - Vett.n. 002317 (05-06)

blanchina
panoramica

- Lave-glace
- Scheibenwischer

LAVACRISTALLO

- Windshield Washer
- Lava-parabrisas

E3.01

modif.	n. ordinaz.	quant.	Denominazione	Désignation	Benennung	Description	Denominaciones
	1114883	1	Cornice	Corniche	Rahmen	Bezel	Marco
	1114884	1	Guarnizione	Joint	Dichtung	Gaske	Junta
	4069392	1	Serbatoio	Réservoir	Behälter	Tank	Depósito
	4070061	1	Serbatoio	Réservoir	Behälter	Tank	Depósito
	4124516	2	Spruzzatore	Gicleur	Spritzdüse	Jet	Surtidor
	4125052	1	Serbatoio - 02 - 04 - 06 -	Réservoir	Behälter	Tank	Depósito
	4125053	1	Serbatoio - 02 - 04 - 06 -	Réservoir	Behälter	Tank	Depósito
	4129430	1	Pompetta	Pompe	Pumpe	Pump	Bomba
	10396280	1	Anello isolante	Isolant	Isolerring	Insulator	Aislador
	10794011	2	Dado	Ecrou	Mutter	Nut	Tuerca
	12605170	2	Rosetta dentata	Rondelle frein	Sicherungsring	Lockwasher	Arandela dentada
	12605370	2	Rosetta dentata	Rondelle frein	Sicherungsring	Lockwasher	Arandela dentada
	15896211	2	Dado	Ecrou	Mutter	Nut	Tuerca
	19052880	m	Tubi raccordo per spruzzatori 2×3,8×250	Tuyau	Spritzleitung	Pipes	Tubos
	19052980	m	Tubo al raccordo 4×6×450	Tuyau	Spritzleitung	Pipe	Tubo
	24912551	1	Raccordo a tre vie	Raccord	Stutzen	Connection	Racor

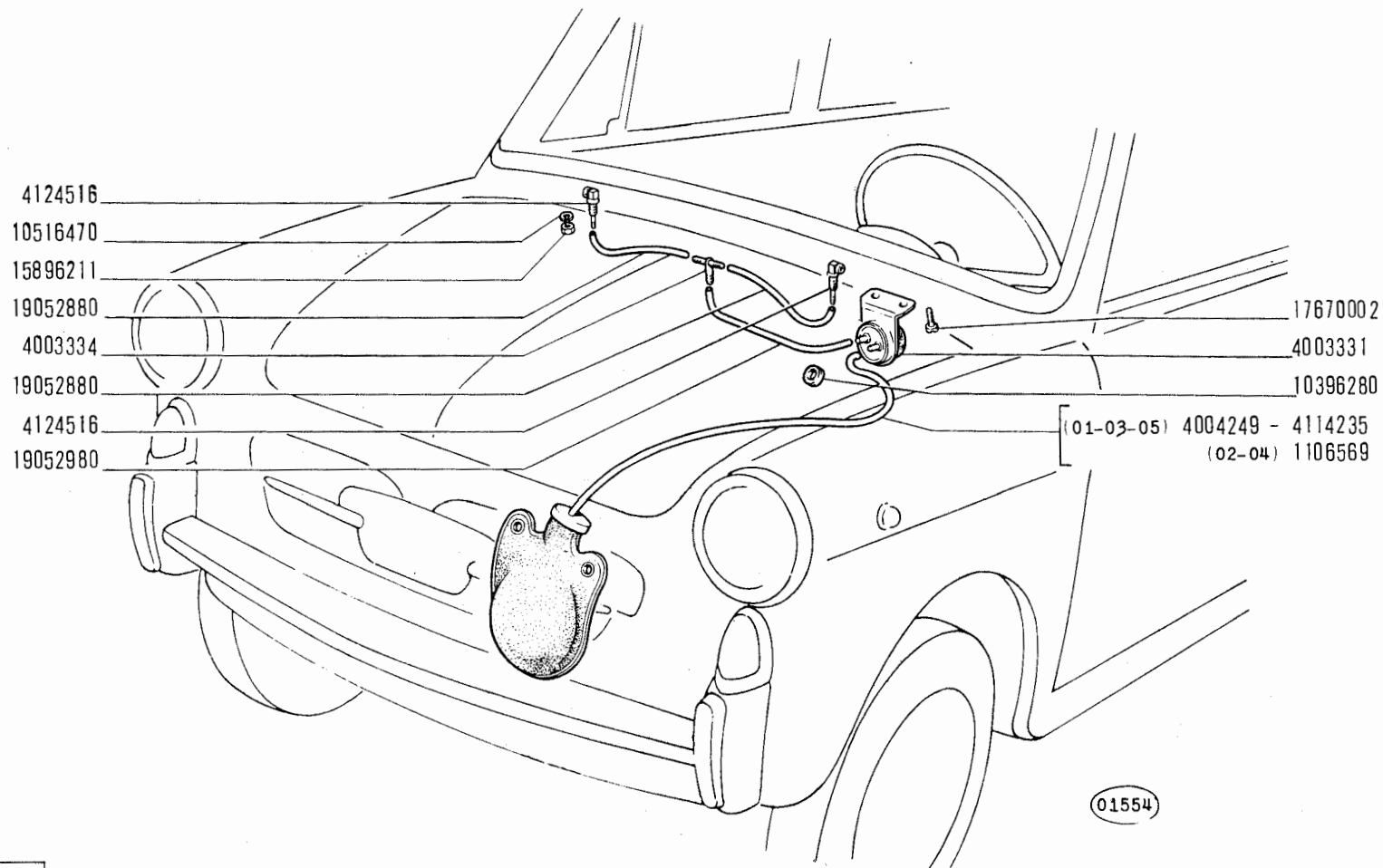

C 4830 → Vett.n. 142249 (01-02) - Vett.n. 147774 (03-04) - Vett.n. 002316 (05-06)

bianchina
panoramica
 e derivati

LAVACRISTALLO

- Lave-glace
- Scheibenwascher

- Windshield Washer
- Lava-parabrisas

E3.01/1

modif.	n. ordinaz.	quant.	Denominazione	Désignation	Benennung	Description	Denominaciones
	1106569	1	Serbatoio - 02 - 04 -	Réservoir	Behälter	Tank	Depósito
	4003331	1	Pompa	Pompe	Pumpe	Pump	Bomba
	4003334	1	Raccordo tre vie	Raccord	Stutzen	Connection	Racor
	4004249	1	Serbatoio - 01 - 03 - 05 -	Réservoir	Behälter	Tank	Depósito
	4114235	1	Serbatoio - 01 - 03 - 05 -	Réservoir	Behälter	Tank	Depósito
	4124516	2	Spruzzatore	Gicleur	Düse	Jet	Surtidor
	10396280	1	Anello isolante	Bague	Isolerring	Insulator	Guarnición
	10516470	2	Rosetta elastica	Rondelle frein	Sicherungsring	Lockwasher	Arandela elástica
	15896211	2	Dado	Écrou	Mutter	Nut	Tuerca
	17670002	2	Vite	Vis	Schraube	Screw	Tornillo
	19052880	m	Tubi raccordo, per spruzzatori 2×3,8×250	Tuyau	Spritzleitung	Pipe	Tubo
	19052980	m	Tubo al raccordo 4×6×450	Tuyau	Spritzleitung	Pipe	Tubo

4124516
10516470
15896211
19052880
24912551
19052880
4124516
19052980

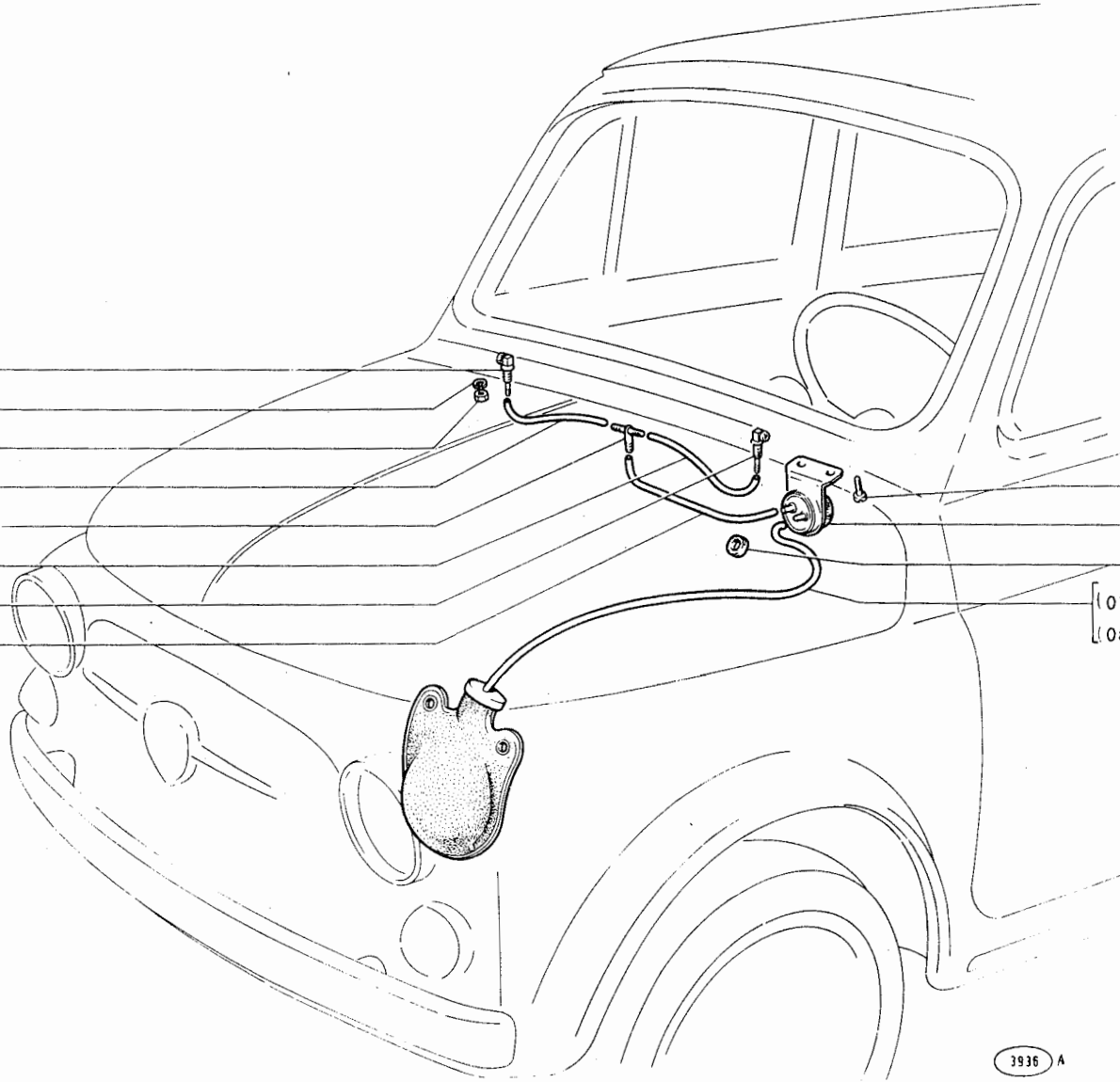

17670002
4003331
10396280
(07) 4135574 - 4135575
(08) 4125052 - 4125053

bianchina
panoramica
e derivati

LAVACRISTALLO

- Lave-glace
- Scheibenwascher

- Windshield Washer
- Lava-parabrisas

E3.01/2

modif.	n. ordinaz.	quant.	Denominazione	Désignation	Benennung	Description	Denominaciones
	4003331	1	Pompa	Pompe	Pumpe	Pump	Bomba
	4124516	2	Spruzzatore	Gicleur	Spritzdüse	Jet	Surtidor
	4125052	1	Serbatoio - 08 -	Réservoir	Behälter	Tank	Depósito
	4125053	1	Serbatoio - 08 -	Réservoir	Behälter	Tank	Depósito
	4135574	1	Serbatoio - 07 -	Réservoir	Behälter	Tank	Depósito
	4135575	1	Serbatoio - 07 -	Réservoir	Behälter	Tank	Depósito
	10396280	1	Anello isolante	Isolant	Isolerring	Insulator	Aislador
	10516470	2	Rosetta elastica	Rondelle frein	Sicherungsring	Lockwasher	Arandela elástica
	15896211	2	Dado	Ecrou	Mutter	Nut	Tuerca
	17670002	2	Vite	Vis	Schraube	Screw	Tornillo
	19052880	m	Tubi raccordo per spruzzatori 2x3,8x250	Tuyaux	Spritzleitung	Pipe	Tubos
	19052980	m	Tubo al raccordo 4x6x450	Tuyau	Spritzleitung	Pipe	Tubo
	24912551	1	Raccordo a tre vie	Raccord	Stutzen	Connection	Racor

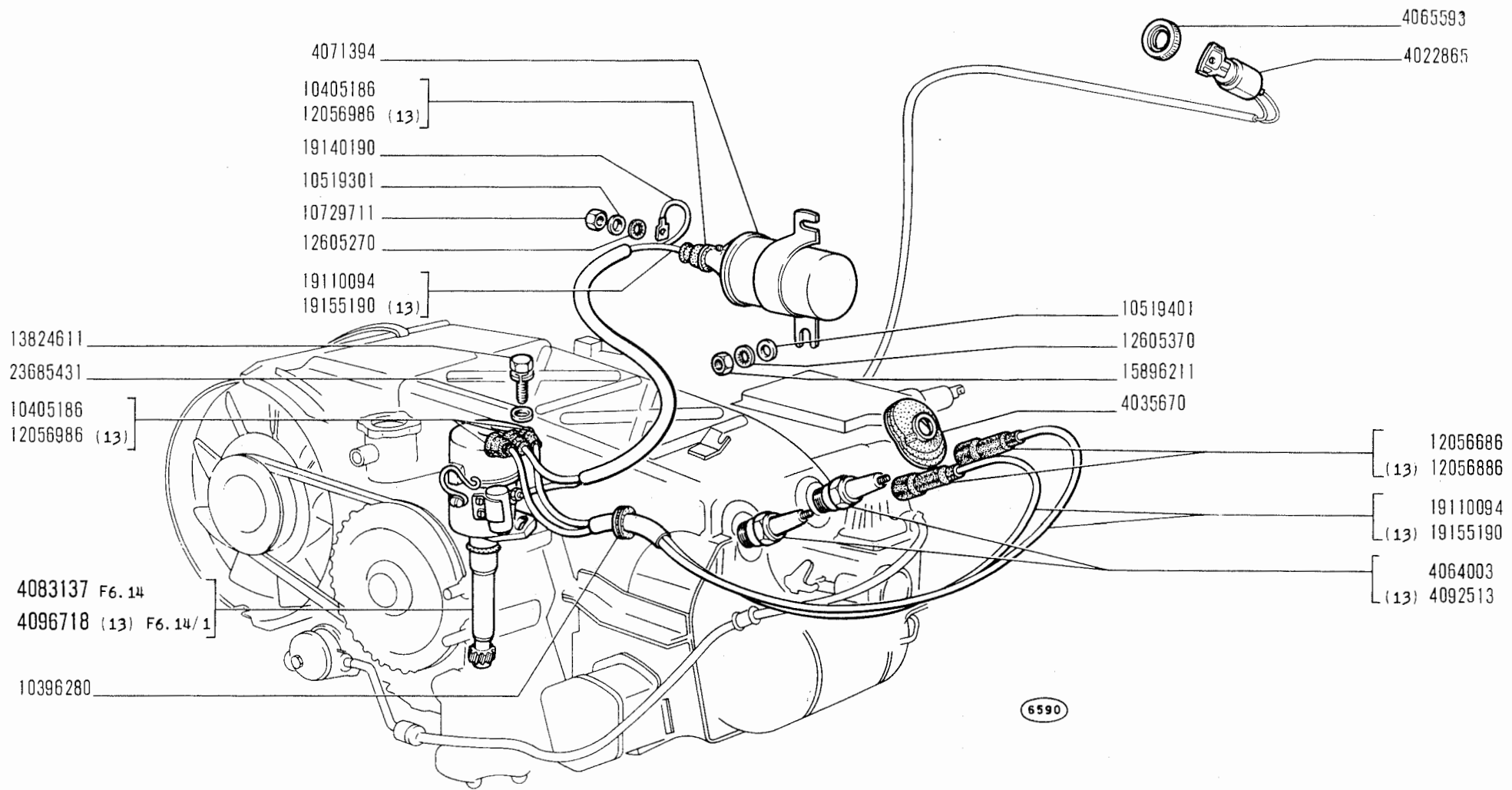

ACCENSIONE MOTORE

- Allumage moteur
- Motorzündung

- Engine Ignition System
- Encendido del motor

modif.	n. ordinaz.	quant.	Denominazione	Désignation	Benennung	Description	Denominaciones
	4022865	1	Interruttore	Interrupteur	Schalter	Switch	Interruptor
	4035670	2	Cappuccio	Capuchon	Schutzkappe	Boot	Capuchón
	4064003	2	Candela	Bougie	Kerze	Spark plug	Bujía
	4065593	1	Ghiera	Écrou	Gewinding	Ring nut	Tuerca
	4071394	1	Rocchetto	Bobine	Zündspule	Coil	Bobina
	4083137	1	Distributore compl.	Allumeur	Zündverteiler	Distributor	Distribuidor
	4092513	2	Candela - 13 -	Bougie	Kerze	Spark plug	Bujía
	4096718	1	Distributore compl. - 13 -	Allumeur	Zündverteiler	Distributor	Distribuidor
	10396280	1	Anello isolante	Bague	Isolerring	Insulator	Guarnición
	10405186	4	Cappuccio	Capuchon	Schutzkappe	Boot	Capuchón
	10519301	2	Rosetta piana	Rondelle	Scheibe	Washer	Arandela
	10519401	2	Rosetta piana	Rondelle	Scheibe	Washer	Arandela
	10729711	2	Dado	Écrou	Mutter	Nut	Tuerca
	12056686	2	Cappuccio	Capuchon	Schutzkappe	Boot	Capuchón
	12056886	2	Cappuccio - 13 -	Capuchon	Schutzkappe	Boot	Capuchón
	12056986	4	Cappuccio - 13 -	Capuchon	Schutzkappe	Boot	Capuchón
	12605270	2	Rosetta dentata	Rondelle frein	Sicherungsring	Lockwasher	Arandela dentada
	12605370	2	Rosetta dentata	Rondelle frein	Sicherungsring	Lockwasher	Arandela dentada
	13824611	1	Vite	Vis	Schraube	Screw	Tornillo
	15896211	2	Dado	Écrou	Mutter	Nut	Tuerca
	19110094	T	Cavo candele e alta tensione	Câble	Leitung	Cable	Cable
	19140190	T	Cavo bassa tensione	Câble	Leitung	Cable	Cable
	19155190	T	Cavo candele e alta tensione - 13 -	Câble	Leitung	Cable	Cable
	23685431	1	Rosetta piana	Rondelle	Scheibe	Washer	Arandela

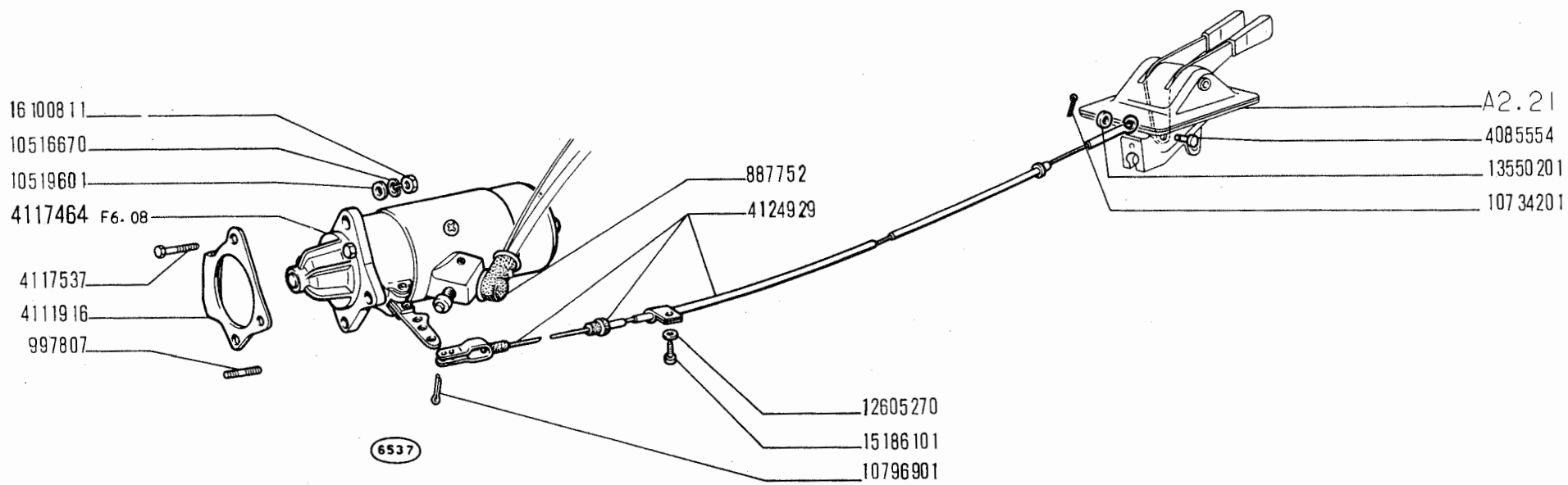

blanchina
panoramica
 e derivati

AVVIAMENTO MOTORE

- Lancement du moteur
- Anlassen des Motors

- Engine Starting Equipment
- Arranque del motor

F2.01

modif.	n. ordinaz.	quant.	Denominazione	Désignation	Benennung	Description	Denominaciones
	887752	1	Cappuccio	Capuchon	Schutzkappe	Boot	Capuchón
	997807	2	Prigioniero	Goujon	Stiftschraube	Stud	Espárrago
	4085554	1	Perno	Axe	Bolzen	Pin	Pasador
	4111916	1	Coperchio	Couvercle	Deckel	Cover	Tapa
	4117464	1	Motorino compl.	Moteur	Motor	Starter motor	Motor
	4117537	1	Vite	Vis	Schraube	Screw	Tornillo
	4124929	1	Trasmissione	Transmission	Bowdenzug	Flex/shaft	Árbol flexible
	10516670	3	Rosetta elastica	Rondelle frein	Sicherungsring	Lockwasher	Arandela elástica
	10519601	3	Rosetta piana	Rondelle	Scheibe	Washer	Arandela
	10734201	1	Copiglia spaccata	Goupille	Splint	Pin	Pasador abierto
	10796901	1	Copiglia spaccata	Goupille	Splint	Pin	Pasador abierto
	12605270	1	Rosetta dentata	Rondelle frein	Sicherungsring	Lockwasher	Arandela dentada
	13550201	1	Rosetta piana	Rondelle	Scheibe	Washer	Arandela
	15186101	1	Vite	Vis	Schraube	Screw	Tornillo
	16100811	3	Dado	Écrou	Mutter	Nut	Tuerca

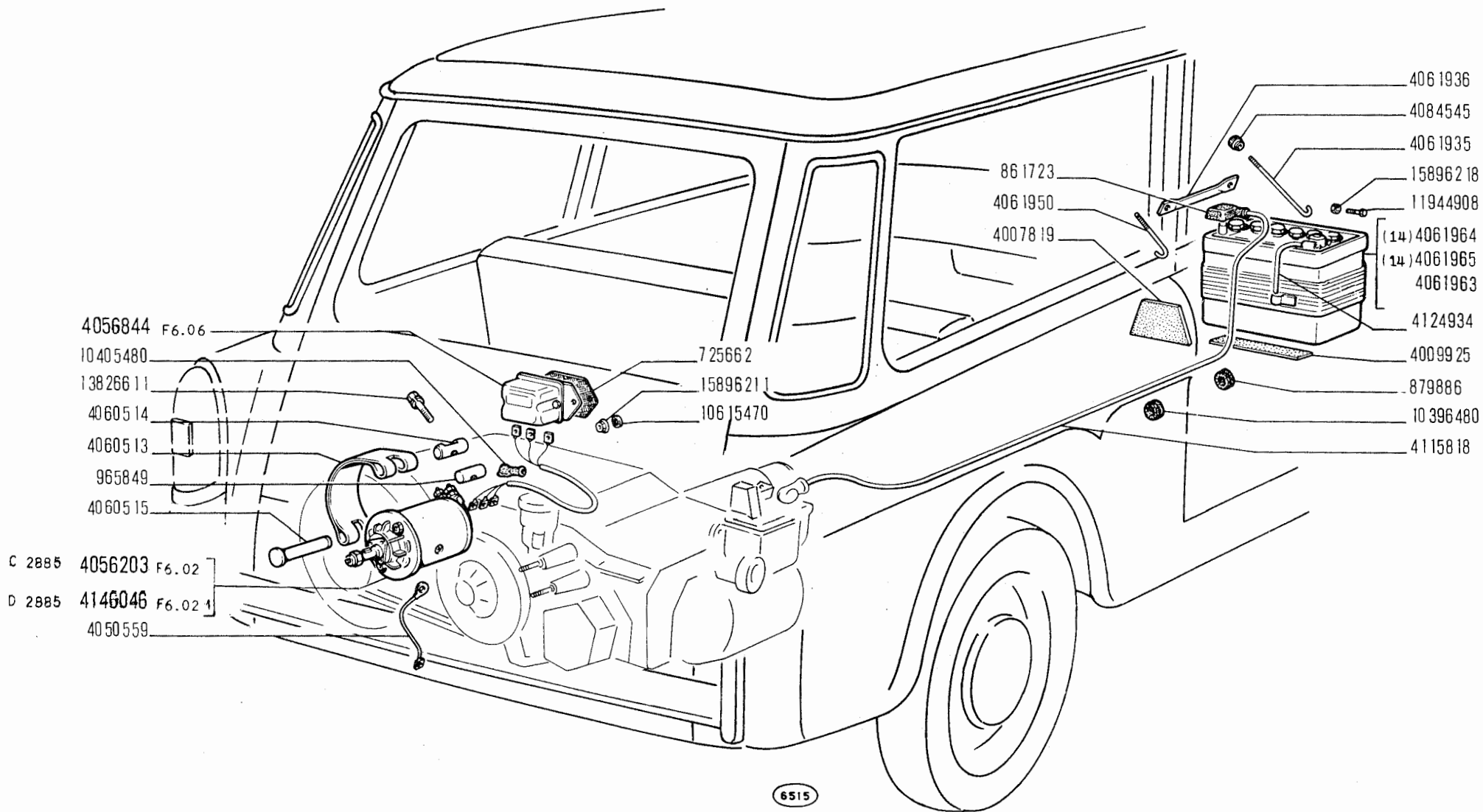

blanchina
panoramica
derivati

GENERAZIONE DI CORRENTE

- Génératrice
- Stromerzeugung

- Current Generating System
- Generator de corriente

F3.01

modif.	n. ordinaz.	quant.	Denominazione	Désignation	Benennung	Description	Denominaciones
	725662	1	Isolante	Isolant	Isolierung	Insulator	Aislador
	861723	1	Cappuccio	Capuchon	Schutzkappe	Boot	Capucha
	879886	1	Anello isolante	Bague	Isolerring	Insulator	Guarnición
	965849	1	Perno	Axe	Bolzen	Pin	Pasador
	4007819	1	Isolante lat.	Isolant	Isolierung	Insulator	Aislador
	4009925	2	Tassello isolante	Tampon	Gummistück	Pad	Almohadilla
	4050559	1	Cavo massa motore	Fil de masse	Massekabel	Ground cable	Cable de masa
C 2885	4056203	1	Dinamo compl.	Dynamo	Lichtmaschine	Generator	Dinamo
	4056844	1	Gruppo regolazione compl.	Régulateur	Reglergruppe	Regulator	Regulador
	4060513	1	Fascia	Collier	Schelle	Collar	Collar
	4060514	1	Perno sup.	Axe	Bolzen	Pin	Pasador
	4060515	1	Perno inf.	Axe	Bolzen	Pin	Pasador
	4061935	1	Tirante lungo	Tirant	Spannbolzen	Tie rod	Perno
	4061936	1	Staffa	Étrier	Halter	Bracket	Soporte
	4061950	1	Tirante corto	Tirant	Spannbolzen	Tie rod	Perno
	4061963	1	Batteria 32 Ah	Batterie	Batterie	Battery	Bateria
	4061964	1	Batteria 32 Ah - 14 -	Batterie	Batterie	Battery	Bateria
	4061965	1	Batteria 32 Ah - 14 - (carica secca)	Batterie (charge sèche)	Batterie (trocken geladen)	Battery (dry charge)	Bateria (carga seca)
	4084545	2	Pomello	Bouton	Knebelgriff	Knob	Botón
	4115818	1	Cavo batteria motorino	Câble	Leitung	Cable	Cable
	4124934	1	Cavo massa-batteria	Fil de masse	Massekabel	Ground cable	Cable de masa
D 2885	4146046	1	Dinamo	Dynamo	Lichtmaschine	Generator	Regulador
	10396480	1	Anello isolante	Bague	Isolerring	Ring	Guarnición
	10405480	1	Cappuccio	Capuchon	Schutzkappe	Boot	Capucha
	10615470	2	Rosetta dentata	Rondelle	Sicherungsring	Lockwasher	Arandela dentada
	11944908	2	Vite	Vis	Schraube	Screw	Tornillo
	13826611	1	Vite sup.	Vis	Schraube	Screw	Tornillo
	15896211	2	Dado	Écrou	Mutter	Nut	Tuerca
	15896218	2	Dado	Écrou	Mutter	Nut	Tuerca

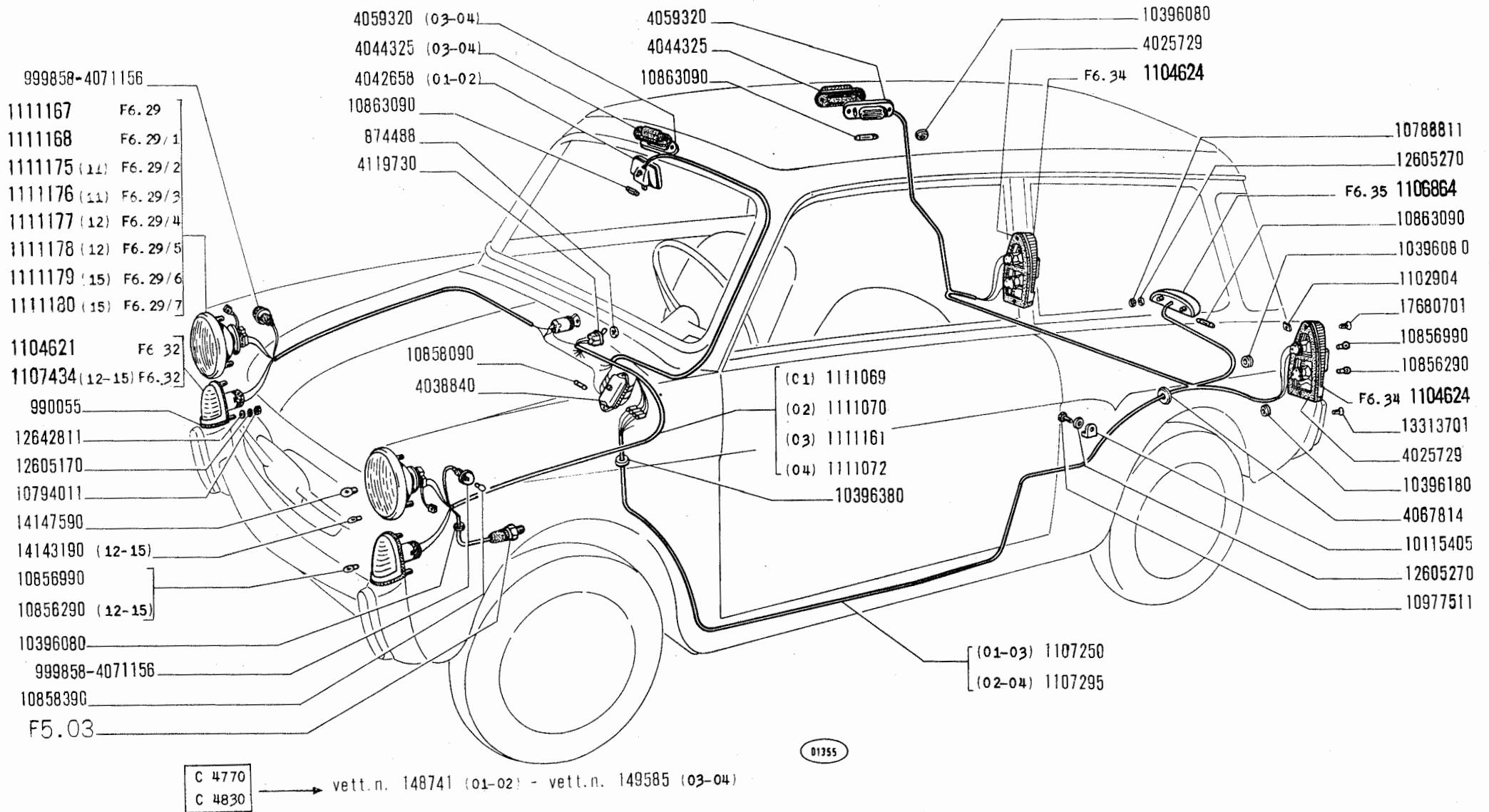

blanchina
panoramica

ILLUMINAZIONE ESTERNA ED INTERNA

- Eclairage extérieur et intérieur
- Aussen- und Innenbeleuchtung

- Outer and Inner Lighting
- Alumbrado exterior e interior

F4.01

modif.	n. ordinaz.	quant.	Denominazione	Désignation	Benennung	Description	Denominaciones
	874488	1	Rosetta piana	Rondelle	Scheibe	Washer	Arandela
	990055	2	Guarnizione	Joint	Dichtung	Gasket	Junta
	999858	2	Fanale lat.	Feu latéral	Blinkleuchte	Side lamp	Lámpara lateral
	1102904	2	Piastrina	Plaque	Plättchen	Plate	Sujetador
	1104621	2	Fanale ant. compl.	Lanterne AV	Vordere Leuchte	Front lamp	Lámpara anterior
	1104624	2	Fanale post.	Lanterne AR	Hintere Leuchte	Tail lamp	Lámpara posterior
	1106864	1	Fanale targa compl.	Feu de plaque	Nummernschildleuchte	Number plate lamp	Lámpara de matrícula
	1107250	1	Insieme cavi post. - 01 - 03 -	Câbles assemblés	Leitungssatz	Cable assy.	Haz de cables
	1107295	1	Insieme cavi post. - 02 - 04 -	Câbles assemblés	Leitungssatz	Cable assy.	Haz de cables
	1107434	2	Fanale ant. compl. - 12 - 15 -	Lanterne AV	Vordere Leuchte	Front lamp	Lámpara anterior
	1111069	1	Insieme cavi cruscotto - 01 -	Câbles assemblés	Leitungssatz	Cable assy.	Haz de cables
	1111070	1	Insieme cavi cruscotto - 02 -	Câbles assemblés	Leitungssatz	Cable assy.	Haz de cables
	1111072	1	Insieme cavi cruscotto - 04 -	Câbles assemblés	Leitungssatz	Cable assy.	Haz de cables
	1111161	1	Insieme cavi cruscotto - 03 -	Câbles assemblés	Leitungssatz	Cable assy.	Haz de cables
	1111167	2	Proiettore compl.	Projecteur	Scheinwerfer	Headlamp	Projector
	1111168	2	Proiettore compl.	Projecteur	Scheinwerfer	Headlamp	Projector
	1111175	2	Proiettore compl. - 11 -	Projecteur	Scheinwerfer	Headlamp	Projector
	1111176	2	Proiettore compl. - 11 -	Projecteur	Scheinwerfer	Headlamp	Projector
	1111177	2	Proiettore compl. - 12 -	Projecteur	Scheinwerfer	Headlamp	Projector
	1111178	2	Proiettore compl. - 12 -	Projecteur	Scheinwerfer	Headlamp	Projector
	1111179	2	Proiettore compl. - 15 -	Projecteur	Scheinwerfer	Headlamp	Projector
	1111180	2	Proiettore compl. - 15 -	Projecteur	Scheinwerfer	Headlamp	Projector
	4025729	2	Guarnizione	Joint	Dichtung	Gasket	Junta
	4038840	1	Scatola valvole	Boîte à fusibles	Sicherungsdose	Fuse box	Caja de fusibles
	4042658	1	Specchio retrovisore - 01 - 02 -	Rétroviseur	Rückblickspiegel	Mirror	Espejo
	4044325	1	Cappuccio	Capuchon	Schutzkappe	Boot	Capucha
	4044325	2	Cappuccio - 03 - 04 -	Capuchon	Schutzkappe	Boot	Capucha
	4059320	1	Portalampada	Porte-lampe	Lampenfassung	Bulb holder	Porta lámpara
	4059320	2	Portalampada - 03 - 04 -	Porte-lampe	Lampenfassung	Bulb holder	Porta lámpara
	4067814	1	Anello isolante	Bague	Isoliering	Insulator	Guarnición
	4071156	2	Fanale lat.	Feu latéral	Blinkleuchte	Side lamp	Lámpara lateral
	4119730	1	Interruttore	Interrupteur	Schalter	Switch	Interruptor
	10115405	1	Staffetta	Collier	Schelle	Retainer	Abrazadera
	10396080	3	Anello isolante	Bague	Isoliering	Insulator	Guarnición

modif.	n. ordinaz.	quant.	Denominazione	Désignation	Benennung	Description	Denominaciones
	10396180	2	Anello isolante	Bague	Isolerring	Insulator	Guarnición
	10396380	1	Anello isolante	Bague	Isolerring	Insulator	Guarnición
	10788811	2	Dado	Écrou	Mutter	Nut	Tuerca
	10794011	6	Dado	Écrou	Mutter	Nut	Tuerca
	10856290	2	Lampada	Lampe	Lampe	Bulb	Lámpara
	10856290	2	Lampada - 12 - 15 -	Lampe	Lampe	Bulb	Lámpara
	10856990	4	Lampada	Lampe	Lampe	Bulb	Lámpara
	10858090	6	Valvola 8 A	Fusible	Sicherung	Fuse	Fusible
	10858390	2	Lampada	Lampe	Lampe	Bulb	Lámpara
	10863090	3	Lampada	Lampe	Lampe	Bulb	Lámpara
	10977511	1	Vite	Vis	Schraube	Screw	Tornillo
	12605170	6	Rosetta dentata	Rondelle frein	Sicherungsring	Lockwasher	Arandela dentata
	12605270	3	Rosetta dentata	Rondelle frein	Sicherungsring	Lockwasher	Arandela dentata
	12642811	6	Rosetta piana	Rondelle	Scheibe	Washer	Arandela
	13313701	2	Vite inferiore	Vis	Schraube	Screw	Tornillo
	14143190	2	Lampada - 12 - 15 -	Lampe	Lampe	Bulb	Lámpara
	14147590	2	Lampada	Lampe	Lampe	Bulb	Lámpara
	17680701	2	Vite sup. autofilet.	Vis	Schraube	Screw	Tornillo

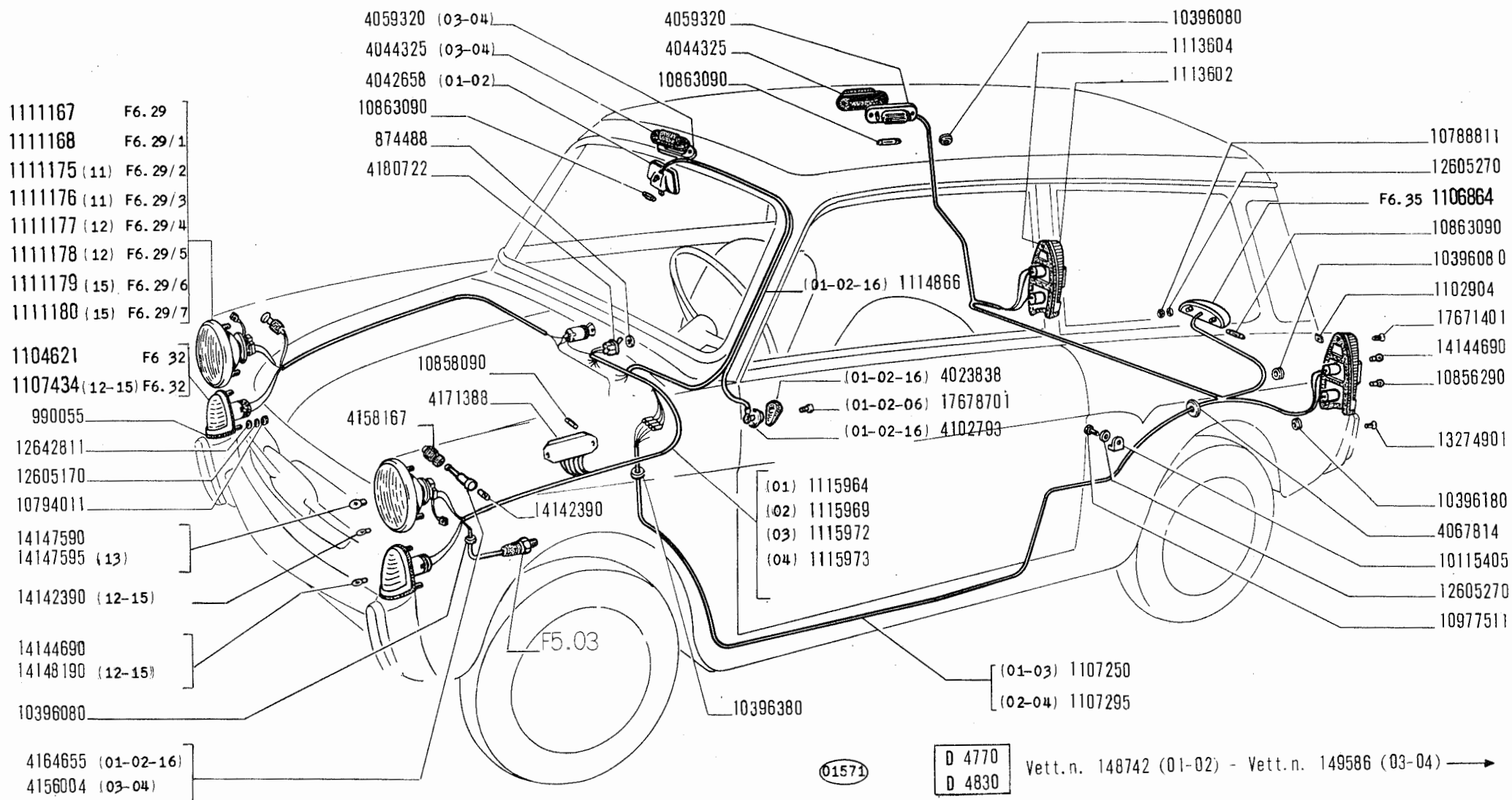

blanchina
panoramica

ILLUMINAZIONE ESTERNA ED INTERNA

- Eclairage extérieur et intérieur
- Aussen- und Innenbeleuchtung

- Outer and Inner Lighting
- Alumbrado exterior e interior

F4.01/1

modif.	n. ordinaz.	quant.	Denominazione	Désignation	Benennung	Description	Denominaciones
	874488	1	Rosetta piana	Rondelle	Scheibe	Washer	Arandela
	990055	2	Guarnizione	Joint	Dichtung	Gasket	Junta
	1102904	2	Piastrina	Plaquette	Plättchen	Plate	Placa
	1104621	2	Fanale ant. compl.	Lanterne AV	Vordere Leuchte	Front lamp	Lámpara anterior
	1106864	1	Fanale targa compl.	Feu de plaque	Nummernschildleuchte	Number plate lamp	Lámpara da matrícula
	1107250	1	Insieme cavi post. - 01 - 03 -	Faisceau de câbles	Leitungssatz	Cable assy.	Haz de cables
	1107295	1	Insieme cavi post. - 02 - 04 -	Faisceau de câbles	Leistungssatz	Cable assy.	Haz de cables
	1107434	2	Fanale ant. compl. - 12 - 15 -	Lanterne AV	Vordere Leuchte	Front lamp	Lámpara anterior
	1115964	1	Insieme cavi cruscotto - 01 -	Faisceau de câbles	Leistungssatz	Cable assy.	Haz de cables
	1115969	1	Insieme cavi cruscotto - 02 -	Faisceau de câbles	Leistungssatz	Cable assy.	Haz de cables
	1115972	1	Insieme cavi cruscotto - 03 -	Faisceau de câbles	Leitungssatz	Cable assy.	Haz de cables
	1115973	1	Insieme cavi cruscotto - 04 -	Faisceau de câbles	Leitungssatz	Cable assy.	Haz de cables
	1111167	2	Proiettore compl.	Projecteur	Scheinwerfer	Headlamp	Proyector
	1111168	2	Proiettore compl.	Projecteur	Scheinwerfer	Headlamp	Proyector
	1111175	2	Proiettore compl. - 11 -	Projecteur	Scheinwerfer	Headlamp	Proyector
	1111176	2	Proiettore compl. - 11 -	Projecteur	Scheinwerfer	Headlamp	Proyector
	1111177	2	Proiettore compl. - 12 -	Projecteur	Scheinwerfer	Headlamp	Proyector
	1111178	2	Proiettore compl. - 12 -	Projecteur	Scheinwerfer	Headlamp	Proyector
	1111179	2	Proiettore compl. - 15 -	Projecteur	Scheinwerfer	Headlamp	Proyector
	1111180	2	Proiettore compl. - 15 -	Projecteur	Scheinwerfer	Headlamp	Proyector
	1113602	2	Fanale post.	Lanterne AR	Hintere Leuchte	Tail lamp	Lámpara posterior
	1113604	2	Guarnizione	Joint	Dichtung	Gasket	Junta
	1114866	1	Cavo specchio pulsante - 01 - 02 - 16 -	Câble	Leitung	Cable	Cable
	4042658	1	Specchio retrovisore	Miroir rétroviseur	Rückblickspiegel	Rear view mirror	Espejo retrovisor
	4044325	1	Cappuccio	Capuchon	Schutzkappe	Boot	Capucha
	4059320	1	Portalampada	Porte-lampe	Lampenfassung	Bulb holder	Portalámpara
	4059320	2	Portalampada - 03 - 04 -	Porte-lampe	Lampenfassung	Bulb holder	Portalámpara
	4067814	1	Anello isolante	Bague	Isolierring	Insulator	Aislador
	4102793	1	Pulsante - 01 - 02 - 16 -	Poussoir	Druckschalter	Button	Botón
	4123838	1	Cappuccio - 01 - 02 - 16 -	Capuchon	Schutzkappe	Boot	Capucha
	4156004	2	Fanale lat. - 03 - 04 -	Feu latéral	Blinkleuchte	Side lamp	Lámpara lateral
	4158167	2	Cappuccio	Capuchon	Schutzkappe	Boot	Capucha
	4164655	2	Fanale lat. - 01 - 02 - 16 -	Feu latéral	Blinkleuchte	Side lamp	Lámpara lateral
	4171388	1	Scatola valvole	Boîte à fusibles	Sicherungsdose	Fusebox	Caja de fusibles

modif.	n. ordinaz.	quant.	Denominazione	Désignation	Benennung	Description	Denominaciones
	4180722	1	Interruttore	Interrupteur	Schalter	Switch	Interruptor
	10115405	1	Staffetta	Bride	Halter	Retainer	Soporte
	10396080	3	Anello isolante	Bague	Isolierring	Insulator	Aislador
	10396180	2	Anello isolante	Bague	Isolierring	Insulator	Aislador
	10396380	1	Anello isolante	Bague	Isolierring	Insulator	Aislador
	10788811	2	Dado	Ecrou	Mutter	Nut	Tuerca
	10794011	6	Dado	Ecrou	Mutter	Nut	Tuerca
	10856290	2	Lampada	Lampe	Lampe	Bulb	Lámpara
	10858090	6	Valvola 8 A.	Fusible	Sicherung	Fuse	Fusible
	10863090	3	Lampada	Lampe	Lampe	Bulb	Lámpara
	10977511	1	Vite	Vis	Schraube	Screw	Tornillo
	12605170	6	Rosetta dentata	Rondelle frein	Sicherungsring	Lockwasher	Arandela dentada
	12605270	3	Rosetta dentata	Rondelle frein	Sicherungsring	Lockwasher	Arandela dentada
	12642811	6	Rosetta piana	Rondelle	Scheibe	Washer	Arandela
	13274901	2	Vite inf.	Vis	Schraube	Screw	Tornillo
	14142390	2	Lampada - 12 - 15 -	Lampe	Lampe	Bulb	Lámpara
	14142390	2	Lampada	Lampe	Lampe	Bulb	Lámpara
	14144690	4	Lampada	Lampe	Lampe	Bulb	Lámpara
	14147590	2	Lampada	Lampe	Lampe	Bulb	Lámpara
	14147595	2	Lampada - 13 -	Lampe	Lampe	Bulb	Lámpara
	14148190	2	Lampada - 12 - 15 -	Lampe	Lampe	Bulb	Lámpara
	17671401	2	Vite sup.	Vis	Schraube	Screw	Tornillo
	17678701	1	Vite	Vis	Schraube	Screw	Tornillo

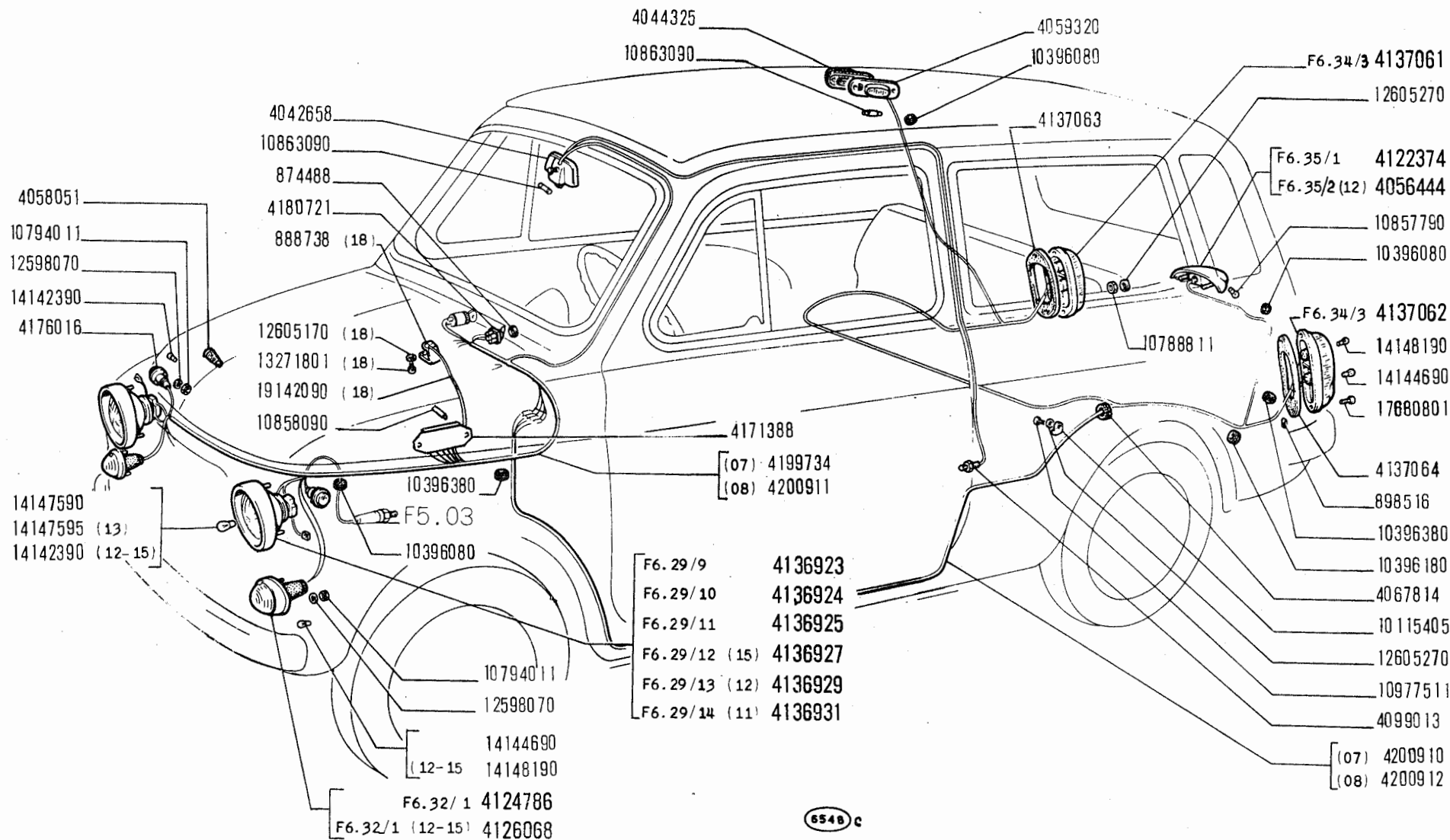

blanchina
panoramica
e derivati

ILLUMINAZIONE ESTERNA ED INTERNA

- *Éclairage extérieur et intérieur*
- *Aussen- und Innenbeleuchtung*

- *Outer and Inner Lighting*
- *Alumbrado exterior e interior*

F4.01/2

modif.	n. ordinaz.	quant.	Denominazione	Désignation	Benennung	Description	Denominaciones
	874488	1	Rosetta piana	Rondelle	Scheibe	Washer	Arandela
	888738	1	Presa corrente - 18 -	Prise de courant	Steckdose	Receptacle	Enchufe
	898516	4	Piastrina	Plaquette	Plättchen	Plate	Placa
	4042658	1	Specchio retrovisore	Miroir rétroviseur	Rückblickspiegel	Rear view mirror	Espejo retrovisor
	4044325	1	Cappuccio	Capuchon	Schutzkappe	Boot	Capucha
	4056444	1	Fanale targa compl. - 12 -	Feu de plaque	Nummernschildleuchte	Number plate lamp	Lámpara de matrícula
	4058051	2	Cappuccio	Capuchon	Schutzkappe	Boot	Capucha
	4059320	1	Porta lampada	Porte-lampe	Lampenfassung	Bulb holder	Portalámpara
	4067814	1	Anello isolante	Bague	Isolerring	Insulator	Aislador
	4099013	1	Pulsante	Poussoir	Druckschalter	Button	Botón
	4122374	1	Fanale targa compl.	Feu de plaque	Nummernschildleuchte	Number plate lamp	Lámpara de matrícula
	4124786	2	Fanale ant. compl.	Lanterne AV	Vordere Leuchte	Front lamp	Lámpara anterior
	4126068	2	Fanale ant. compl. - 12 - 15 -	Lanterne AV	Vordere Leuchte	Front lamp	Lámpara anterior
	4136923	2	Proiettore compl.	Projecteur	Scheinwerfer	Headlamp	Proyector
	4136924	2	Proiettore compl.	Projecteur	Scheinwerfer	Headlamp	Proyector
	4136925	2	Proiettore compl.	Projecteur	Scheinwerfer	Headlamp	Proyector
	4136927	2	Proiettore compl. - 15 -	Projecteur	Scheinwerfer	Headlamp	Proyector
	4136929	2	Proiettore compl. - 12 -	Projecteur	Scheinwerfer	Headlamp	Proyector
	4136931	2	Proiettore compl. - 11 -	Projecteur	Scheinwerfer	Headlamp	Proyector
	4137061	1	Fanale post. d	Lanterne AR	Hintere Leuchte	Tail lamp	Lámpara posterior
	4137062	1	Fanale post. s	Lanterne	Hintere Leuchte	Tail lamp	Lámpara posterior
	4137063	1	Guarnizione d	Joint	Dichtung	Gasket	Junta
	4137064	1	Guarnizione s	Joint	Dichtung	Gasket	Junta
	4171388	1	Scatola valvole	Boîte à fusible	Sicherungsdose	Fusebox	Caja de fusibles
	4176016	2	Fanale laterale	Feu latéral	Blinkleuchte	Side lamp	Lámpara lateral
	4180721	1	Interruttore	Interrupteur	Schalter	Switch	Interruptor
	4199734	1	Insieme cavi cruscotto - 07 -	Faisceau de câbles	Leitungssatz	Cable assy.	Haz de cables
	4200910	1	Insieme cavi post. - 07 -	Faisceau de câbles	Leistungssatz	Cable assy.	Haz de cables
	4200911	1	Insieme cavi cruscotto - 08 -	Faisceau de câbles	Leistungssatz	Cable assy.	Haz de cables
	4200912	1	Insieme cavi post. - 08 -	Faisceau de câbles	Leistungssatz	Cable assy.	Haz de cables
	10115405	1	Staffetta	Bride	Halter	Retainer	Soporte
	10396080	5	Anello isolante	Bague	Isolerring	Insulator	Aislador
	10396180	2	Anello isolante	Bague	Isolerring	Insulator	Aislador
	10396380	3	Anello isolante	Bague	Isolerring	Insulator	Aislador

modif.	n. ordinaz.	quant.	Denominazione	Désignation	Benennung	Description	Denominaciones
	10788811	2	Dado	Ecrou	Mutter	Nut	Tuerca
	10794011	8	Dado	Ecrou	Mutter	Nut	Tuerca
	10857790	1	Lampada	Lampe	Lampe	Bulb	Lámpara
	10858090	6	Valvola	Fusible	Sicherung	Fuse	Fusible
	10863090	2	Lampada	Lampe	Lampe	Bulb	Lámpara
	10977511	1	Vite	Vis	Schraube	Screw	Tornillo
	12598070	8	Rosetta elastica	Rondelle frein	Sicherungsring	Lockwasher	Arandela elástica
	12605170	2	Rosetta dentata - 18 -	Rondelle frein	Sicherungsring	Lockwasher	Arandela dentada
	12605270	3	Rosetta dentata	Rondelle frein	Sicherungsring	Lockwasher	Arandela dentada
	13271801	2	Vite - 18 -	Vis	Schraube	Screw	Tornillo
	14142390	2	Lampada	Lampe	Lampe	Bulb	Lámpara
	14144690	4	Lampada	Lampe	Lampe	Bulb	Lámpara
	14147590	2	Lampada	Lampe	Lampe	Bulb	Lámpara
	14147595	2	Lampada - 13 -	Lampe	Lampe	Bulb	Lámpara
	14148190	2	Lampada	Lampe	Lampe	Bulb	Lámpara
	14148190	4	Lampada - 12 - 15 -	Lampe	Lampe	Bulb	Lámpara
	17680801	4	Vite	Vis	Schraube	Screw	Tornillo
	19142090	T	Cavo per presa di corrente - 18 -	Câble	Leitung	Cable	Cable

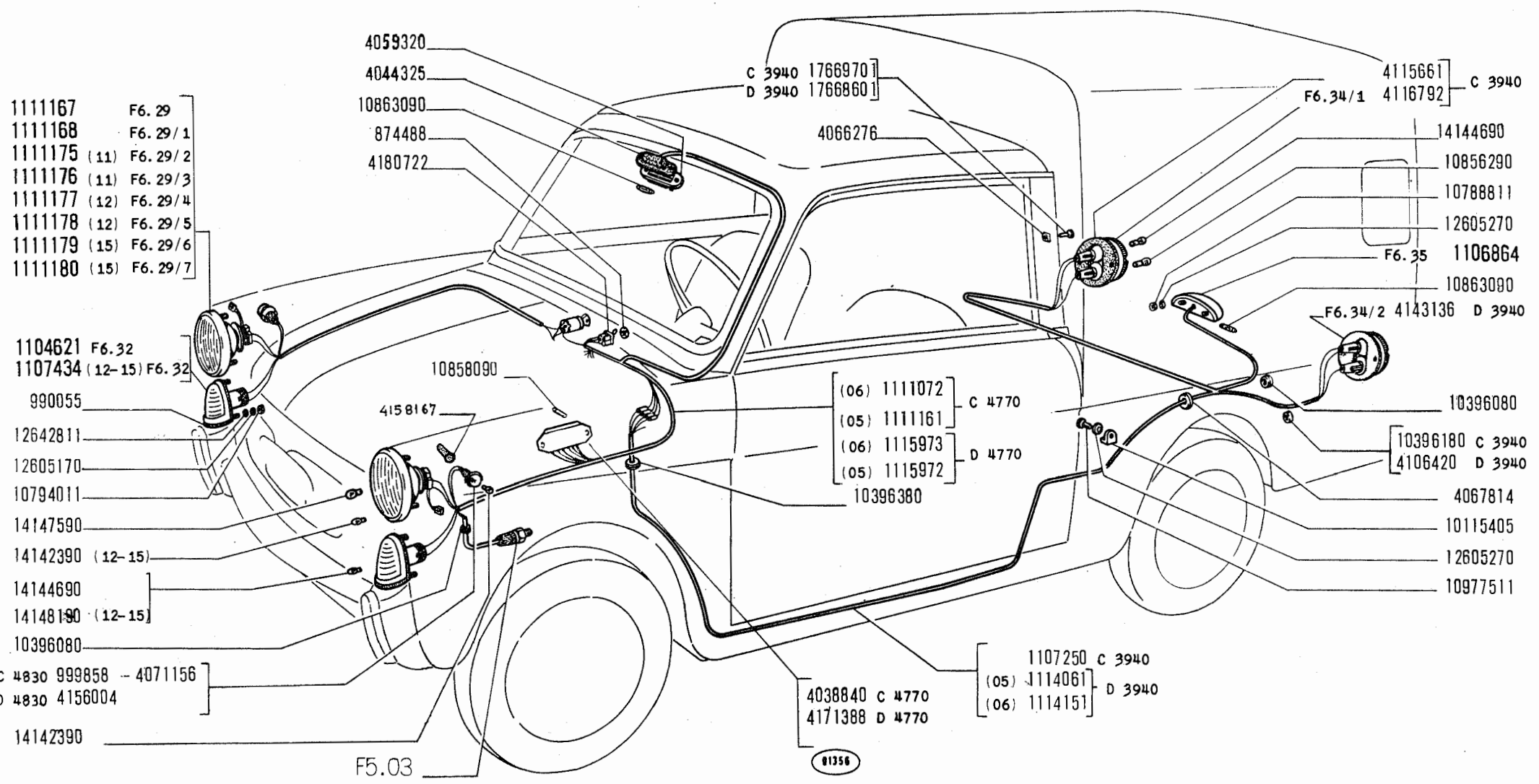

blanchina
panoramica
 e derivati

ILLUMINAZIONE ESTERNA ED INTERNA

- Éclairage extérieur et intérieur
- Aussen- und Innenbeleuchtung

- Outer and Inner Lighting
- Alumbrado exterior y interior

F4.01/3

modif.	n. ordinaz.	quant.	Denominazione	Désignation	Benennung	Description	Denominaciones
	874488	1	Rosetta piana	Rondelle	Scheibe	Washer	Arandela
	990055	2	Guarnizione	Joint	Dichtung	Gasket	Junta
C 4380	999858	2	Fanale lat.	Feu latéral	Blinkleuchte	Side lamp	Lámpara lateral
	1104621	2	Fanale ant. compl.	Feu latéral	Vordere Leuchte	Front lamp	Lámpara anterior
	1106864	1	Fanale targa compl.	Feu de plaque	Nummernschildleuchte	Number plate lamp	Lámpara de matrícula
C 3940	1107250	1	Insieme cavi post.	Faisceau de câbles	Leitungssatz	Cable assy.	Haz de cables
	1107434	2	Fanale ant. compl. - 12 - 15 -	Lanterne AV	Vordere Leuchte	Front lamp	Lámpara anterior
C 4770	1111072	1	Insieme cavi cruscotto - 06 -	Faisceau de câbles	Leitungssatz	Cable assy.	Haz de cables
C 4770	1111161	1	Insieme cavi cruscotto - 05 -	Faisceau de câbles	Leitungssatz	Cable assy.	Haz de cables
	1111167	2	Proiettore compl.	Projecteur	Scheinwerfer	Headlamp	Projector
	1111168	2	Proiettore compl.	Projecteur	Scheinwerfer	Headlamp	Projector
	1111175	2	Proiettore compl. - 11 -	Projecteur	Scheinwerfer	Headlamp	Projector
	1111176	2	Proiettore compl. - 11 -	Projecteur	Scheinwerfer	Headlamp	Projector
	1111177	2	Proiettore compl. - 12 -	Projecteur	Scheinwerfer	Headlamp	Projector
	1111178	2	Proiettore compl. - 12 -	Projecteur	Scheinwerfer	Headlamp	Projector
	1111179	2	Proiettore compl. - 15 -	Projecteur	Scheinwerfer	Headlamp	Projector
	1111180	2	Proiettore compl. - 15 -	Projecteur	Scheinwerfer	Headlamp	Projector
D 3940	1114061	1	Insieme cavi post. - 05 -	Faisceau de câbles	Leitungssatz	Cable assy.	Haz de cables
D 3940	1114151	1	Insieme cavi post. - 06 -	Faisceau de câbles	Leitungssatz	Cable assy.	Haz de cables
D 4770	1115972	1	Insieme cavi cruscotto - 05 -	Faisceau de câbles	Leitungssatz	Cable assy.	Haz de cables
D 4770	1115973	1	Insieme cavi cruscotto - 06 -	Faisceau de câbles	Leitungssatz	Cable assy.	Haz de cables
C 4770	4038840	1	Scatola valvole	Boîte à fusibles	Sicherungsdose	Fusebox	Caja de fusibles
	4044325	2	Cappuccio	Capuchon	Schutzkappe	Boot	Capucha
	4059320	2	Portalampada	Porte-lampe	Lampenfassung	Bulb holder	Portalampara*
	4066276	4	Piastrina	Plaquette	Plättchen	Plate	Placa
	4067814	1	Anello isolante	Bague	Isolerring	Insulator	Aislador
C 4830	4071156	2	Fanale laterale	Feu latéral	Blinkleuchte	Side lamp	Lámpara lateral
D 3940	4106420	2	Anello isolante	Bague	Isolerring	Insulator	Aislador
C 3940	4115661	2	Guarnizione	Joint	Dichtung	Gasket	Junta
C 3940	4116792	2	Fanale post.	Lanterne AR	Hintere Leuchte	Tail lamp	Lámpara posterior
D 3940	4143136	2	Fanale post.	Lanterne AR	Hintere Leuchte	Tail lamp	Lámpara posterior
D 4830	4156004	2	Fanale laterale	Lanterne AR	Blinkleuchte	Side lamp	Lámpara lateral
D 4770	4171388	1	Scatola valvole	Boîte à fusibles	Sicherungsdose	Fuse box	Caja de fusibles
	4180722	1	Interruttore	Interrupteur	Schalter	Switch	Interruptor

modif.	n. ordinaz.	quant.	Denominazione	Désignation	Benennung	Description	Denominaciones
	10115405	1	Staffetta	Bride	Halter	Retainer	Soporte
	10396080	3	Anello isolante	Bague	Isolierring	Insulator	Aislador
C 3940	10396180	2	Anello isolante	Bague	Isolierring	Insulator	Aislador
	10396380	1	Anello isolante	Bague	Isolierring	Insulator	Aislador
	10788811	2	Dado	Ecrou	Mutter	Nut	Tuerca
	10794011	6	Dado	Ecrou	Mutter	Nut	Tuerca
	10856290	2	Lampada	Lampe	Lampe	Bulb	Lámpara
	10858090	6	Valvola 8 A	Fusible	Sicherung	Fuse	Fusible
	10863090	3	Lampada	Lampe	Lampe	Bulb	Lámpara
	10977511	1	Vite	Vis	Schraube	Screw	Tornillo
	12605170	6	Rosetta dentata	Rondelle frein	Sicherungsring	Lockwasher	Arandela dentada
	12605270	3	Rosetta dentata	Rondelle frein	Sicherungsring	Lockwasher	Arandela dentada
	12642811	6	Rosetta piana	Rondelle	Scheibe	Washer	Arandela
	14142390	2	Lampada - 12 - 15 -	Lampe	Lampe	Bulb	Lámpara
	14144690	4	Lampada	Lampe	Lampe	Bulb	Lámpara
	14147590	2	Lampada	Lampe	Lampe	Bulb	Lámpara
	14148190	2	Lampada - 12 - 15 -	Lampe	Lampe	Bulb	Lámpara
D 3940	17668601	4	Vite	Vis	Schraube	Screw	Tornillo
C 3940	17669701	4	Vite	Vis	Schraube	Screw	Tornillo

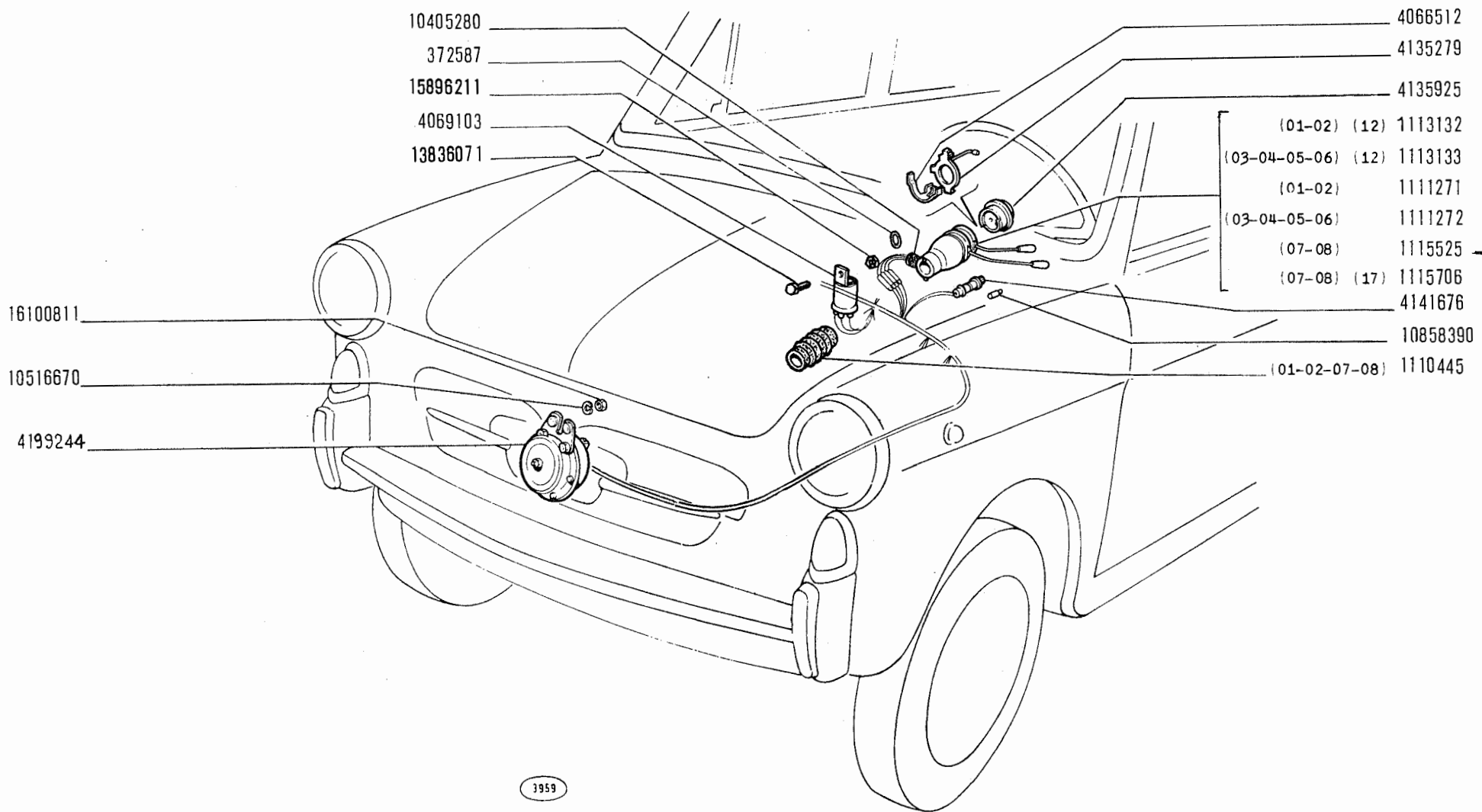

bianchina
panoramica
e derivati

SEGNALAZIONI DI AVVISO E DI MANOVRA

- Signaux d'appel et de manœuvre
- SignalisierVorrichtungen

- Outer Signalling Devices
- Aparatos de Señalización

F5.01

modif.	n. ordinaz.	quant.	Denominazione	Désignation	Benennung	Description	Denominaciones
	372587	2	Anello isolante	Bague	Isolierring	Insulator	Aislador
	1110445	1	Guarnizione - 01 - 02 - 07 - 08 -	Joint	Dichtung	Gasket	Junta
	1111271	1	Devioguida sgancio e devioluci - 01 - 02 -	Combinateur	Lenkstock-Umschalter	Switch unit	Interruptor-conmutador
	1111272	1	Devioguida sgancio e devioluci - 03 - 04 - 05 - 06 -	Combinateur	Lenkstock-Umschalter	Switch unit	Interruptor-conmutador
	1113132	1	Devioguida sgancio e devioluci - 01 - 02 (12) -	Combinateur	Lenkstock-Umschalter	Switch unit	Interruptor-conmutador
	1113133	1	Devioguida sgancio e devioluci - 03 - 04 - 05 - 06 (12) -	Combinateur	Lenkstock-Umschalter	Switch unit	Interruptor-conmutador
	1115525	1	Devioguida sgancio e devioluci - 07 - 08 -	Combinateur	Lenkstock-Umschalter	Switch unit	Interruptor-conmutador
	1115706	1	Devioguida sgancio e devioluci - 07 - 08 (17) -	Combinateur	Lenkstock-Umschalter	Switch unit	Interruptor-conmutador
	4066512	1	Molla comando	Ressort	Feder	Spring	Muelle
	4069103	1	Lampeggiatore	Clignotant	Blinkgeber	Flasher	Relé de intermitencias
	4135279	1	Anello portacorrente	Bague	Kontaktring	Contact ring	Anillo de contacto
	4135925	1	Comando avvisatore	Commande d'avertisseur	Signalhornbetätigung	Horn control	Pulsador de bocina
	4141676	1	Indicatore ottico	Témoin	Anzeigeleuchte	Indicator light	Testigo
	4199244	1	Avvisatore	Avertisseur	Signalhorn	Horn	Bocina
	10405280	1	Cappuccio	Capuchon	Schutzkappe	Boot	Capucha
	10516670	2	Rosetta elastica	Rondelle frein	Sicherungsring	Lockwasher	Arandela elástica
	10858390	1	Lampada	Lampe	Lampe	Bulb	Lámpara
	13836071	1	Vite	Vis	Schraube	Screw	Tornillo
	15896211	1	Dado	Ecrou	Mutter	Nut	Tuerca
	16100811	2	Dado	Ecrou	Mutter	Nut	Tuerca

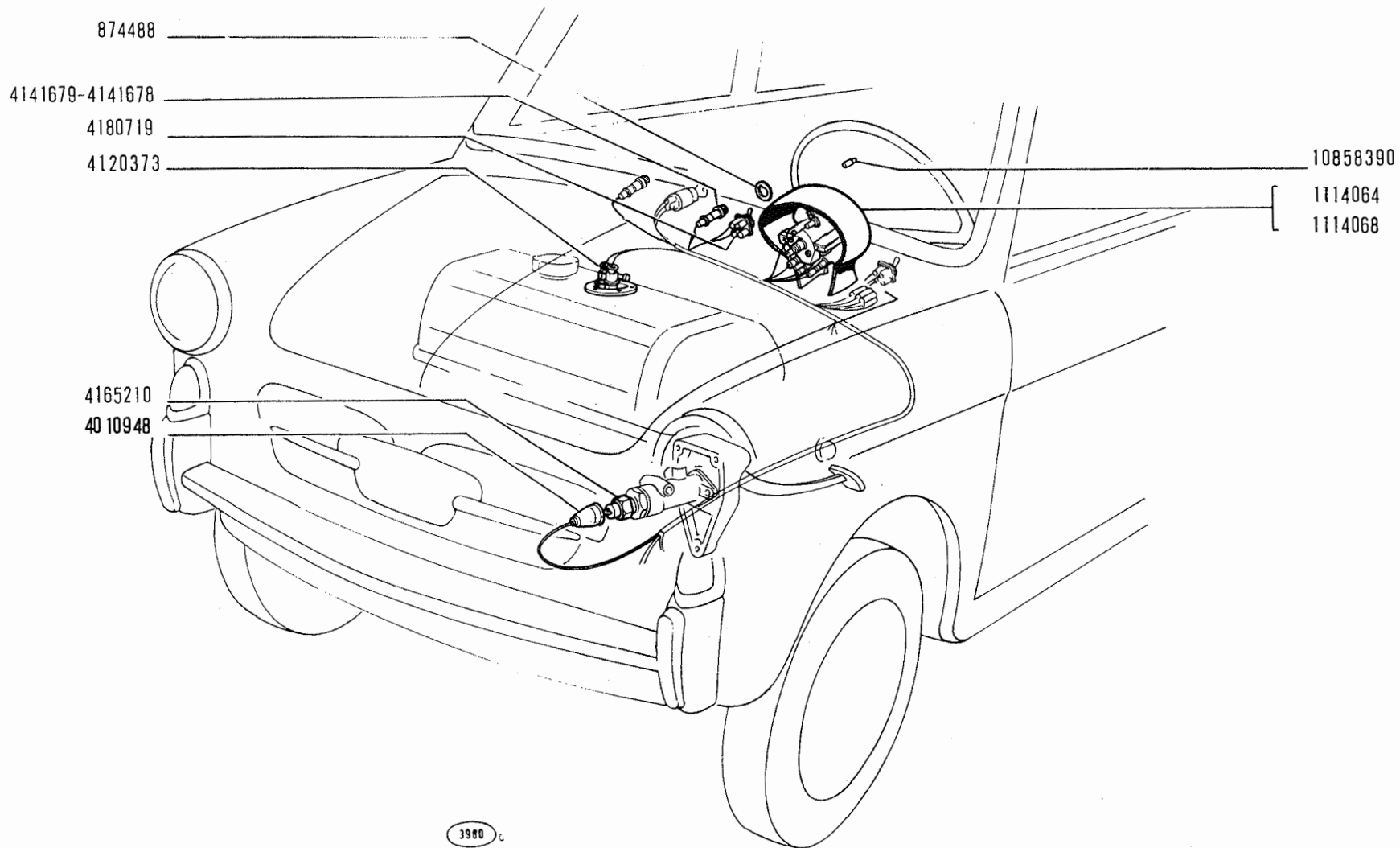

bianchina
panoramica
 e derivati

SEGNALAZIONI DI FUNZIONAMENTO

- *Témoins de fonctionnement*
- *Anzeigevorrichtungen*

- *Operation Indicators*
- *Testigos de funcionamiento*

F5.03

modif.	n. ordinaz.	quant.	Denominazione	Désignation	Benennung	Description	Denominaciones
	874488	1	Rosetta piana	Rondelle	Scheibe	Washer	Arandela
	1105463 *	1	Indicatore livello benzina	Jauge	Standanzeiger	Level gauge	Indicador de nivel
	1105471 *	1	Cornice strumento	Monture	Rahmen	Frame	Marco
	1105475 *	1	Portalamпада	Porte-lampe	Lampenfassung	Bulb holder	Portalámpara
	1105477 *	1	Tachimetro per contamiglia	Combiné - milles -	Meilenzähler	Speedometer - miles -	Velocímetro para millas
	1105478 *	1	Quadrante per contamiglia	Cadran - milles -	Zifferblatt (Meilen)	Dial (Speedom. - in miles)	Esfera para millas
	1114064	1	Strumento con contachilometri	Combiné - km -	Kombiinstrument - Kilo- meter -	Inst/cluster - km -	Cuadro de señalizaciones - km -
	1114068	1	Strumento con contamiglia	Combiné - milles -	Kombiinstrument - Meilen -	Inst/cluster - miles -	Cuadro de señalizaciones - millas -
	4010948	1	Cappuccio	Capuchon	Schutzkappe	Boot	Capucha
	4120373	2	Cappuccio isolante	Capuchon	Schutzkappe	Boot	Capucha
	4141678	1	Indicatore ottico	Lampe-témoin	Anzeigeleuchte	Indicator	Testigo
	4141679	1	Indicatore ottico	Lampe-témoin	Anzeigeleuchte	Indicator	Testigo
	4165210	1	Interruttore	Interrupteur	Schalter	Switch	Interruptor
	4180719	1	Interruttore	Interrupteur	Schalter	Switch	Interruptor
	10858390	5	Lampada	Lampe	Lampe	Bulb	Lámpara
	98090000 *	1	Tachimetro per contachilometri	Combiné - km -	Kilometerzähler	Speedometer - km -	Velocímetro para km
	98090001 *	1	Quadrante per contachilometri	Cadran - kilomètres -	Zifferblatt (km)	Dial (speedom. in km)	Esfera para km
			(*) Particolari non illustrati sulla tavola.	(*) Pièces non illustrées dans la planche.	(*) Nicht abgebildet.	(*) Parts not illustrated on the plate.	(*) No se ilustra en la lámina.

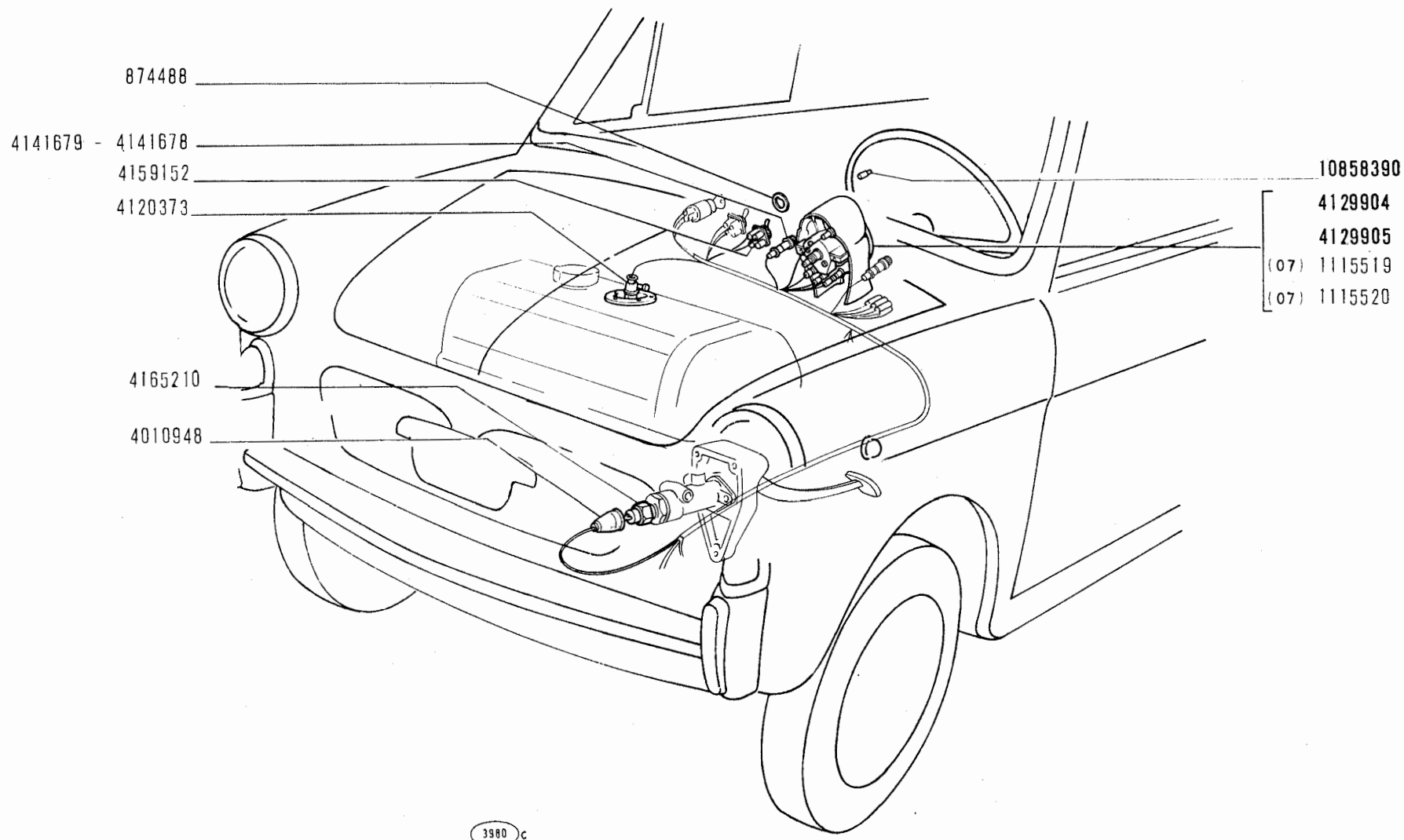

bianchina
panoramica

SEGNALAZIONI DI FUNZIONAMENTO

- *Témoins de fonctionnement*
- *Anzeigevorrichtungen*

- *Operation Indicators*
- *Testigos de funcionamiento*

F5.03/1

modif.	n. ordinaz.	quant.	Denominazione	Désignation	Benennung	Description	Denominaciones
	874488	1	Rosetta piana	Rondelle	Scheibe	Washer	Arandela
	1115519	1	Strumento con contachilometri - 07 -	Combiné-kilomètres	Kombiinstrument - Kilometer -	Inst. cluster - km -	Cuadro de señalizaciones - km
	1115520	1	Strumento con contamiglia - 07 -	Combiné-milles	Kombiinstrument - Meilen -	Inst. cluster - miles -	Cuadro de señalizaciones - millas
	4050539	1	Interruttore	Interrupteur	Schalter	Switch	Interruptor
	4100948	1	Cappuccio	Capuchon	Schutzkappe	Boot	Capucha
	4120373	1	Cappuccio isolante	Capuchon	Isolierkappe	Insul. boot	Capucha
	4129904	1	Strumento con contachilometri	Combiné-kilomètres	Kombiinstrument - Kilometer -	Inst. cluster - km -	Cuadro de señalizaciones - km
	4129905	1	Strumento con contamiglia	Combiné-milles	Kombiinstrument - Meilen -	Inst./cluster - miles -	Cuadro de señalizaciones - millas
	4141678	1	Indicatore ottico	Témoin	Anzeigeleuchte	Indicator light	Testigo
	4141679	1	Indicatore ottico	Témoin	Anzeigeleuchte	Indicator light	Testigo
	4159152	1	Interruttore	Interrupteur	Schalter	Switch	Interruptor
	4165210	1	Interruttore	Interrupteur	Schalter	Switch	Interruptor
	10858390	6	Lampada	Lampe	Lampe	Bulb	Lámpara

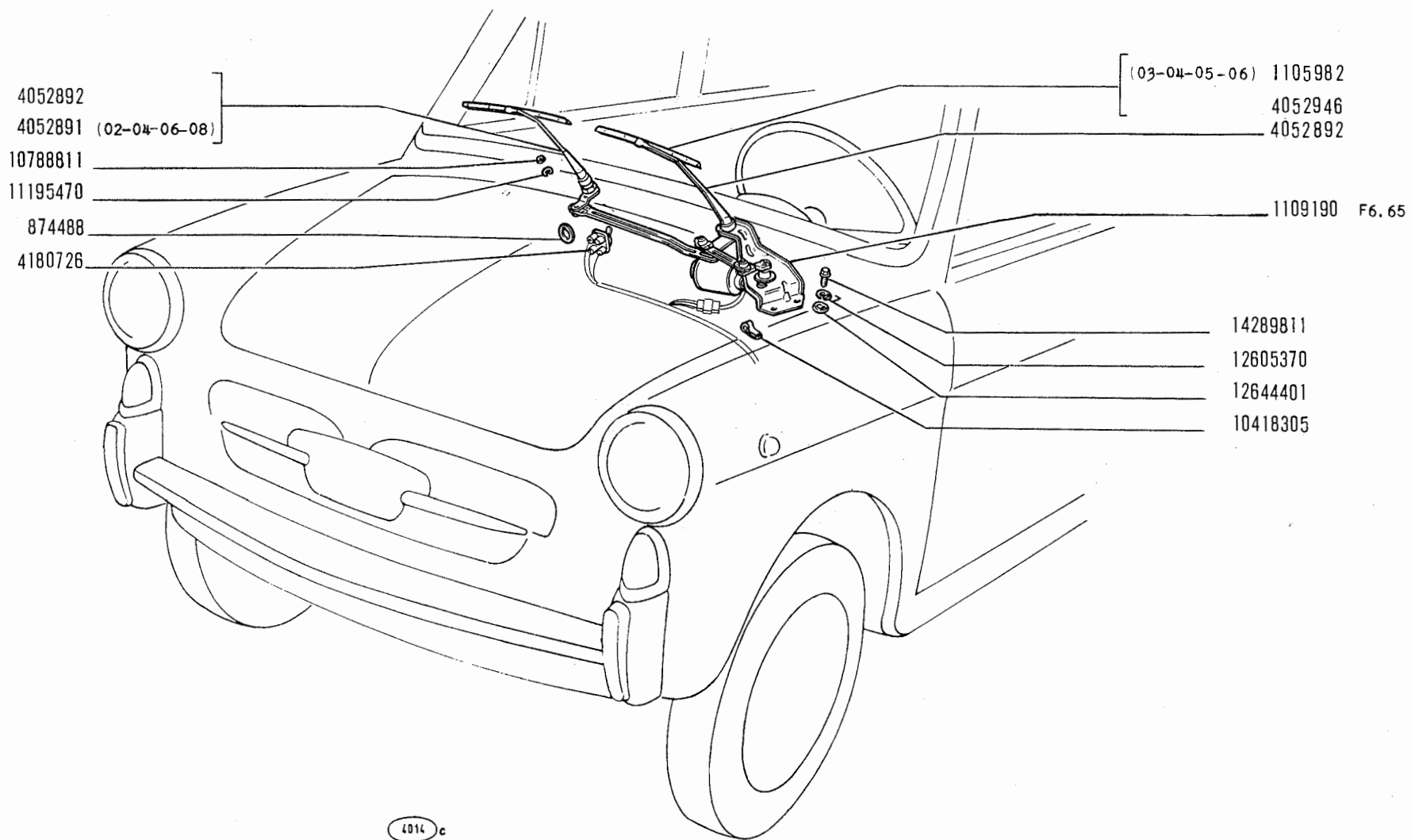

bianchina
panoramica
 c. derivati

ACCESSORI VARI

- Accessoires divers
- Verschiedenes Zubehör

- Accessory Fittings
- Accesorios varios

F5.05

modif.	n. ordinaz.	quant.	Denominazione	Désignation	Benennung	Description	Denominaciones
	874488	1	Rosetta piana	Rondelle	Scheibe	Washer	Arandela
	1105982	2	Spatola (03 - 04 - 05 - 06)	Raclette	Wischblatt	Blade	Rasqueta
	1109190	1	Tergicristallo compl.	Essuie-glace	Scheibenwischer	Windshield wiper	Limpia-parabrisas
	4052891	1	Braccio (02 - 04 - 06 - 08)	Bras	Arm	Arm	Brazo
	4052892	2	Braccio	Bras	Arm	Arm	Brazo
	4052892	1	Braccio (02 - 04 - 06 - 08)	Bras	Arm	Arm	Brazo
	4052946	2	Spatola	Raclette	Wischblatt	Blade	Rasqueta
	4180726	1	Commutatore	Commutateur	Schalter	Switch	Conmutador
	10418305	1	Staffetta	Collier	Schelle	Retainer	Abrazadera
	10788811	2	Dado	Écrou	Mutter	Nut	Tuerca
	11195470	2	Rosetta elastica	Rondelle	Sicherungsring	Lockwasher	Arandela elástica
	12605370	2	Rosetta elastica	Rondelle	Sicherungsring	Lockwasher	Arandela elástica
	12644401	2	Rosetta piana	Rondelle	Scheibe	Washer	Arandela
	14289811	2	Vite	Vis	Schraube	Screw	Tornillo

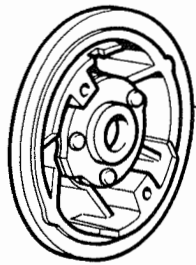

4111374 C 2758
4146047 D 2758

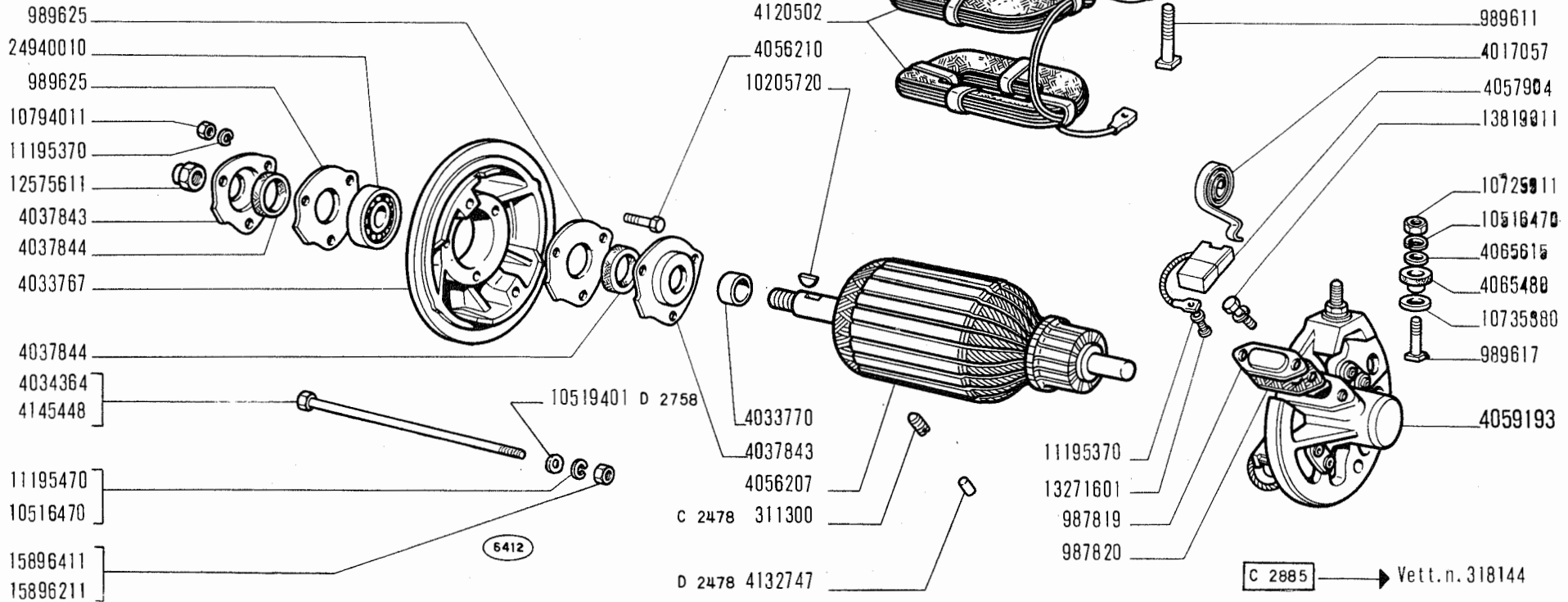

bianchina
panoramica
e derivati

- Dynamo
- Lichtmaschine

DINAMO 4056203

- Generator
- Dinamo

F6.02

modif.	n. ordinaz.	quant.	Denominazione	Désignation	Benennung	Description	Denominaciones
C 2478	311300	1	Grano	Ergot	Passtift	Dowel	Pitón
	883323	2	Vite	Vis	Schraube	Screw	Tornillo
	987819	1	Coperchio	Couvercle	Deckel	Cover	Tapa
	987820	1	Guarnizione	Joint	Dichtung	Gasket	Junta
	989611	1	Vite serrafilo	Vis	Schraube	Screw	Tornillo
	989617	1	Vite serrafilo	Vis	Schraube	Screw	Tornillo
	989625	2	Coperchio	Couvercle	Deckel	Cover	Tapa
	4017057	2	Molla	Ressort	Feder	Spring	Muelle
	4033767	1	Supporto	Support	Lager	Support	Soporte
	4033770	1	Anello tenuta	Joint	Dichtring	Seal	Junta
C 2758	4034364	2	Tirante	Tirant	Spannbolzen	Tie rod	Perno
	4037843	2	Coperchio ritegno	Couvercle	Deckel	Cover	Tapa
	4037844	2	Anello tenuta	Joint	Dichtring	Seal	Junta
	4056207	1	Indotto	Induit	Anker	Armature	Inducido
	4056210	3	Vite	Vis	Schraube	Screw	Tornillo
	4057904	2	Spazzola	Balai	Kohlebürste	Brush	Escobilla
	4059193	1	Supporto compl.	Support	Lager	Support	Soporte
	4065480	1	Tubetto isolante	Isolant	Isolierung	Insulator	Aislador
	4065615	1	Rosetta piana	Rondelle	Scheibe	Washer	Arandela
	4091440	1	Isolante	Isolant	Isolierung	Insulator	Aislador
C 2758	4111374	1	Supporto compl.	Support	Lager	Support	Soporte
	4119858	1	Isolante	Isolant	Isolierung	Insulator	Aislador
	4120502	1	Avvolgimento	Enroulement	Wicklung	Winding	Devanado
D 2478	4132747	1	Grano	Ergot	Passtift	Dowel	Pitón
D 2758	4145448	2	Tirante	Tirant	Spannbolzen	Tie rod	Perno
D 2758	4146047	1	Supporto compl.	Support	Lager	Support	Soporte
	10205720	1	Linguetta	Linguet	Scheibenfeder	Key	Chaveta
D 2758	10516470	2	Rosetta sicurezza	Rondelle frein	Scheibe	Washer	Arandela de freno
	10516470	2	Rosetta sicurezza	Rondelle frein	Sicherungsring	Lockwasher	Aandela de freno
D 2758	10519401	2	Rosetta piana	Rondelle	Scheibe	Washer	Arandela
	10725911	2	Dado	Écrou	Mutter	Nut	Tuerca
	10735880	1	Rosetta isolante	Rondelle isolante	Isolierscheibe	Insulator	Arandela aislante
	10794011	3	Dado	Écrou	Mutter	Nut	Tuerca
	11195370	5	Rosetta sicurezza	Rondelle frein	Sicherungsring	Lockwasher	Arandela de freno

modif.	n. ordinaz.	quant.	Denominazione	Désignation	Benennung	Description	Denominaciones
C 2758	11195470	4	Rosetta sicurezza	Rondelle frein	Sicherungsring	Lockwasher	Arandela de freno
	12575611	1	Dado	Écrou	Mutter	Nut	Tuerca
	13271601	2	Vite	Vis	Schraube	Screw	Tornillo
	13550101	1	Rosetta piana	Rondelle	Scheibe	Washer	Arandela
	13819011	2	Vite	Vis	Schraube	Screw	Tornillo
D 2758	15896211	2	Dado	Écrou	Mutter	Nut	Tuerca
C 2758	15896411	4	Dado	Écrou	Mutter	Nut	Tuerca
	24940010	1	Cuscinetto a sfere	Roulement	Lager	Bearing	Rodamiento

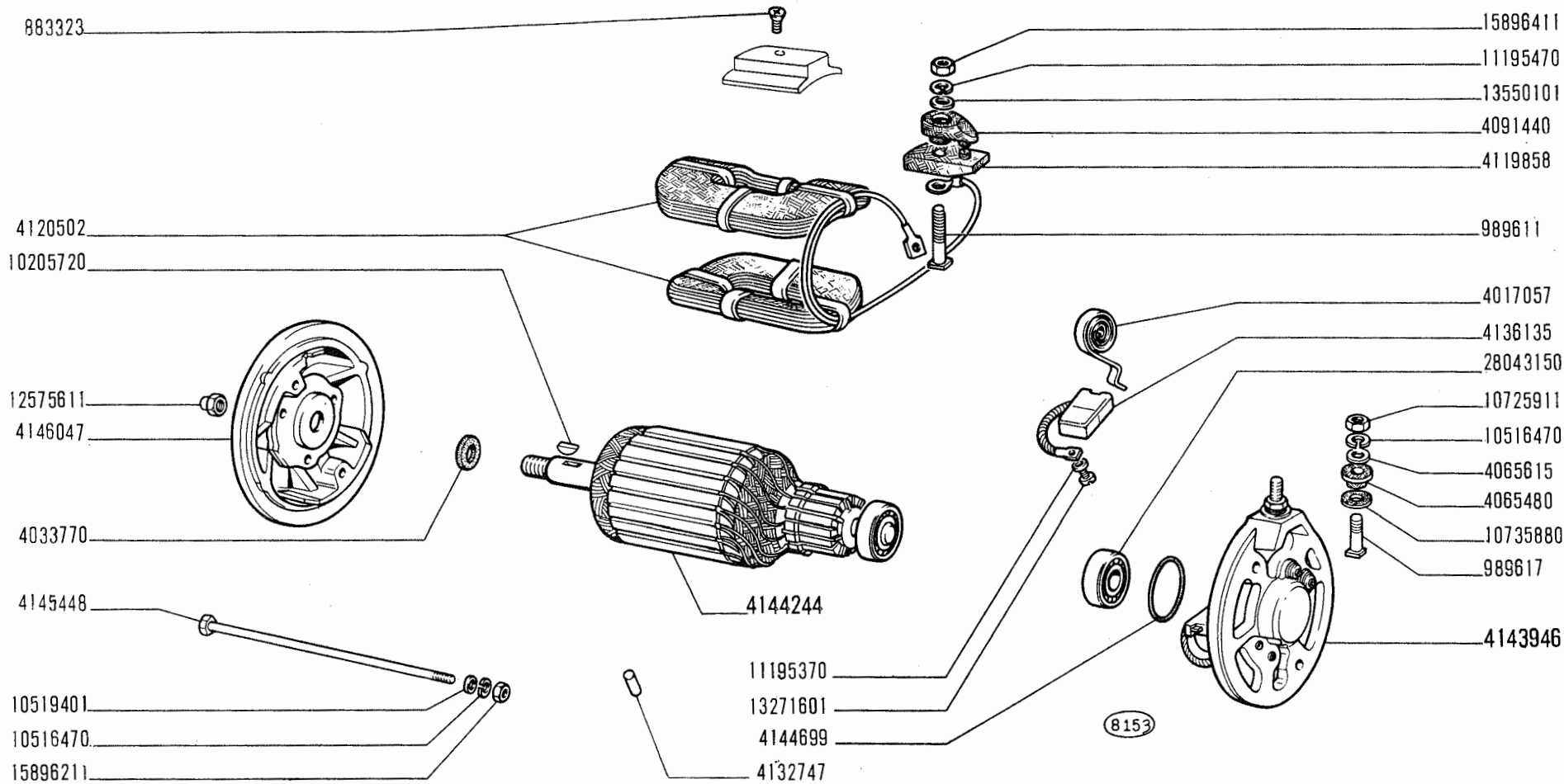

D 2885 Vett. n. 318145 →

bianchina
panoramica
e derivati

- Dynamo
- Lichtmaschine

DINAMO 4146046

- Generator
- Dinamo

F6.02/1

modif.	n. ordinaz.	quant.	Denominazione	Désignation	Benennung	Description	Denominaciones
	883323	2	Vite	Vis	Schraube	Screw	Tornillo
	989611	1	Vite	Vis	Schraube	Screw	Tornillo
	989617	1	Vite	Vis	Schraube	Screw	Tornillo
	4017057	2	Molla	Ressort	Feder	Spring	Muelle
	4033770	1	Anello tenuta	Joint	Dichtring	Seal	Junta
	4065480	1	Isolante	Isolant	Isolierung	Insulator	Aislador
	4065615	1	Rosetta piana	Rondelle	Scheibe	Washer	Arandela
	4075394	1	Rosetta piana	Rondelle	Scheibe	Washer	Arandela
	4091440	1	Isolante	Isolant	Isolierung	Insulator	Aislador
	4119858	1	Isolante	Isolant	Isolierung	Insulator	Aislador
	4120502	1	Avvolgimento	Enroulement	Wicklung	Winding	Devanado
	4132747	1	Grano	Ergot	Passtift	Dowel	Pitón
	4136135	2	Spazzola	Balai	Kohlebürste	Brush	Escobilla
	4143946	1	Supporto compl.	Support	Lager	Head	Soporte
	4144244	1	Indotto compl.	Induit	Anker	Armature	Inducido
	4144699	1	Anello tenuta	Joint	Dichtring	Seal	Junta
	4145448	2	Tirante	Tirant	Spannbolzen	Thru bolt	Perno
	4146047	1	Supporto	Support	Lager	Head	Soporte
	10205720	1	Linguetta	Linguet	Scheibenfeder	Key	Chaveta
	10516470	4	Rosetta sicurezza	Rondelle frein	Sicherungsring	Lockwasher	Arandela de freno
	10519401	2	Rosetta piana	Rondelle	Scheibe	Washer	Arandela
	10725911	2	Dado	Ecrou	Mutter	Nut	Tuerca
	10735880	1	Rosetta isolante	Rondelle isolante	Isolerring	Insulator	Arandela aislante
	11195370	2	Rosetta sicurezza	Rondelle frein	Sicherungsring	Lockwasher	Arandela de freno
	11195470	2	Rosetta sicurezza	Rondelle frein	Sicherungsring	Lockwasher	Arandela de freno
	12575611	1	Dado	Ecrou	Mutter	Nut	Tuerca
	13271601	2	Vite	Vis	Schraube	Screw	Tornillo
	15896211	2	Dado	Ecrou	Mutter	Nut	Tuerca
	15896411	2	Dado	Ecrou	Mutter	Nut	Tuerca
	24940150	1	Cuscinetto a sfere	Roulement à billes	Lager	Bearing	Rodamiento

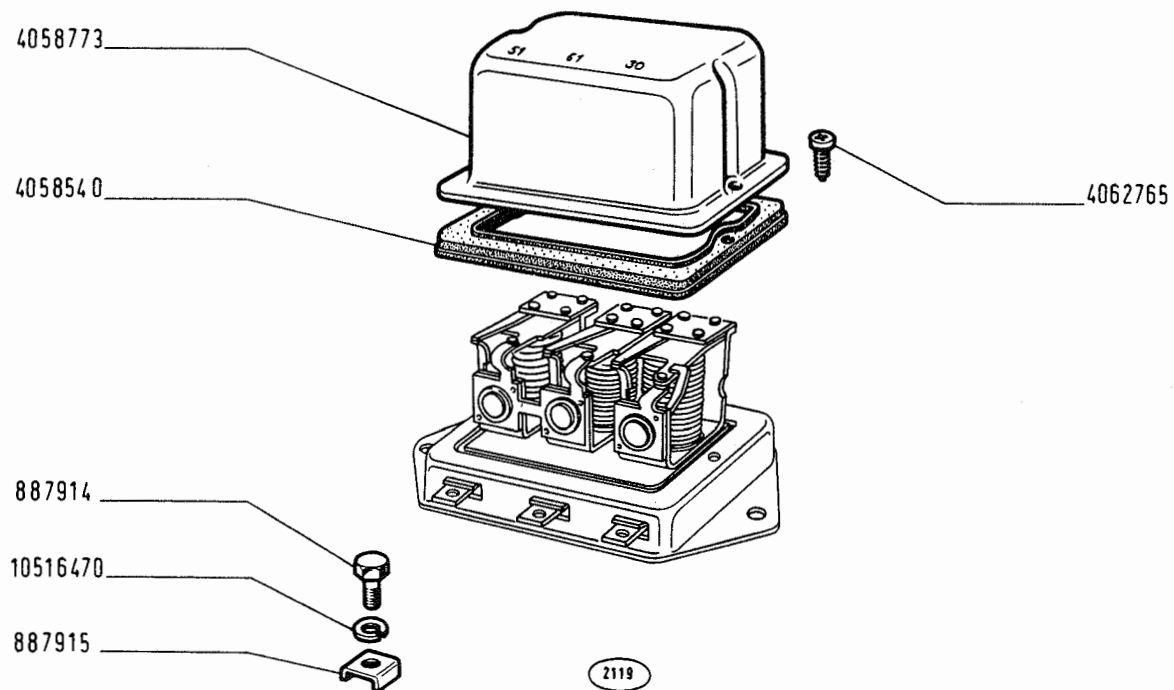

modif.	n. ordinaz.	quant.	Denominazione	Désignation	Benennung	Description	Denominaciones
	887914	3	Vite	Vis	Schraube	Screw	Tornillo
	887915	3	Piastrina	Plaquette	Plättchen	Plate	Placa
	4058540	1	Guarnizione	Joint	Dichtung	Gasket	Junta
	4058773	1	Coperchio	Couvercle	Deckel	Cover	Tapa
	4062765	2	Vite	Vis	Schraube	Screw	Tornillo
	10516470	3	Rosetta sicurezza	Rondelle frein	Sicherungsring	Lockwasher	Arandela de freno

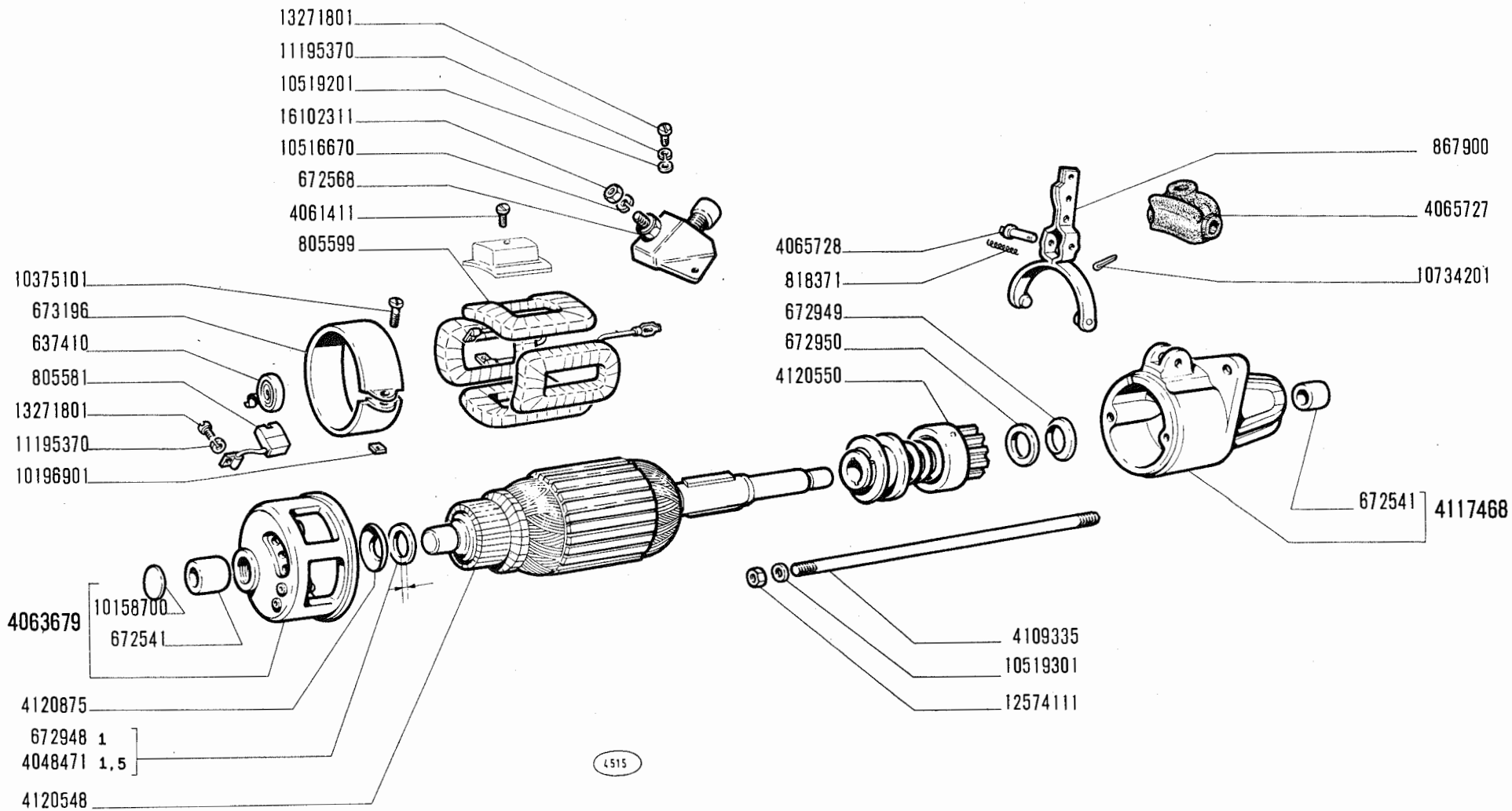

bianchina
panoramica

MOTORINO DI AVVIAMENTO 4117464

- Démarreur
- Anlasser

- Starter Motor
- Motor de arranque

F6.08

modif.	n. ordinaz.	quant.	Denominazione	Désignation	Benennung	Description	Denominaciones
	637410	2	Molla	Ressort	Feder	Spring	Muelle
	672541	2	Boccola	Douille	Büchse	Bush	Casquillo
	672568	1	Interruttore	Interruteur	Schalter	Switch	Interruptor
	672948	1	Rosetta sp. 1	Rondelle	Scheibe	Washer	Arandela
	672949	—	Scodellino	Cuvette	Tellerscheibe	Cup	Platillo
	672950	1	Rosetta piana	Rondelle	Scheibe	Washer	Arandela
	673196	1	Fascia	Collier	Schelle	Collar	Collar
	805581	2	Spazzola	Balai	Kohlebürste	Brush	Escobilla
	805599	1	Avvolgimento	Enroulement	Wicklung	Winding	Devanado
	818371	1	Molla	Ressort	Feder	Spring	Muelle
	867900	1	Leva	Levier	Hebel	Lever	Palanca
	4048471	1	Rosetta sp. 1,5	Rondelle	Scheibe	Washer	Arandela
	4061411	4	Vite	Vis	Schraube	Screw	Tornillo
	4063679	1	Supporto compl.	Support	Lager	Support	Soporte
	4065727	1	Cappuccio	Capuchon	Schutzkappe	Boot	Capuchón
	4065728	1	Perno fissaggio	Axe	Bolzen	Pin	Pasador
	4109335	2	Tirante	Tirant	Spannbolzen	Tie rod	Perno
	4117468	1	Supporto compl.	Support	Lager	Support	Soporte
	4120548	1	Indotto	Induit	Anker	Armature	Inducido
	4120550	1	Innesto avviamento	Enclenchement	Ritzeltrieb	Drive unit	Acoplamiento
	4120875	—	Scodellino	Cuvette	Tellerscheibe	Cup	Platillo
	10158700	1	Tappo	Bouchon	Stopfen	Plug	Tapón
	10196901	1	Dado	Écrou	Mutter	Nut	Tuerca
	10375101	1	Vite	Vis	Schraube	Screw	Tornillo
	10516670	1	Rosetta sicurezza	Rondelle frein	Sicherungsring	Lockwasher	Arandela de freno
	10519201	2	Rosetta piana	Rondelle	Scheibe	Washer	Arandela
	10519301	2	Rosetta piana	Rondelle	Scheibe	Washer	Arandela
	10734201	1	Copiglia	Goupille	Splint	Pin	Pasador abierto
	11195370	4	Rosetta sicurezza	Rondelle frein	Sicherungsring	Lockwasher	Arandela de freno
	12574111	2	Dado	Écrou	Mutter	Nut	Tuerca
	13271801	4	Vite	Vis	Schraube	Screw	Tornillo
	16102311	1	Dado	Écrou	Mutter	Nut	Tuerca

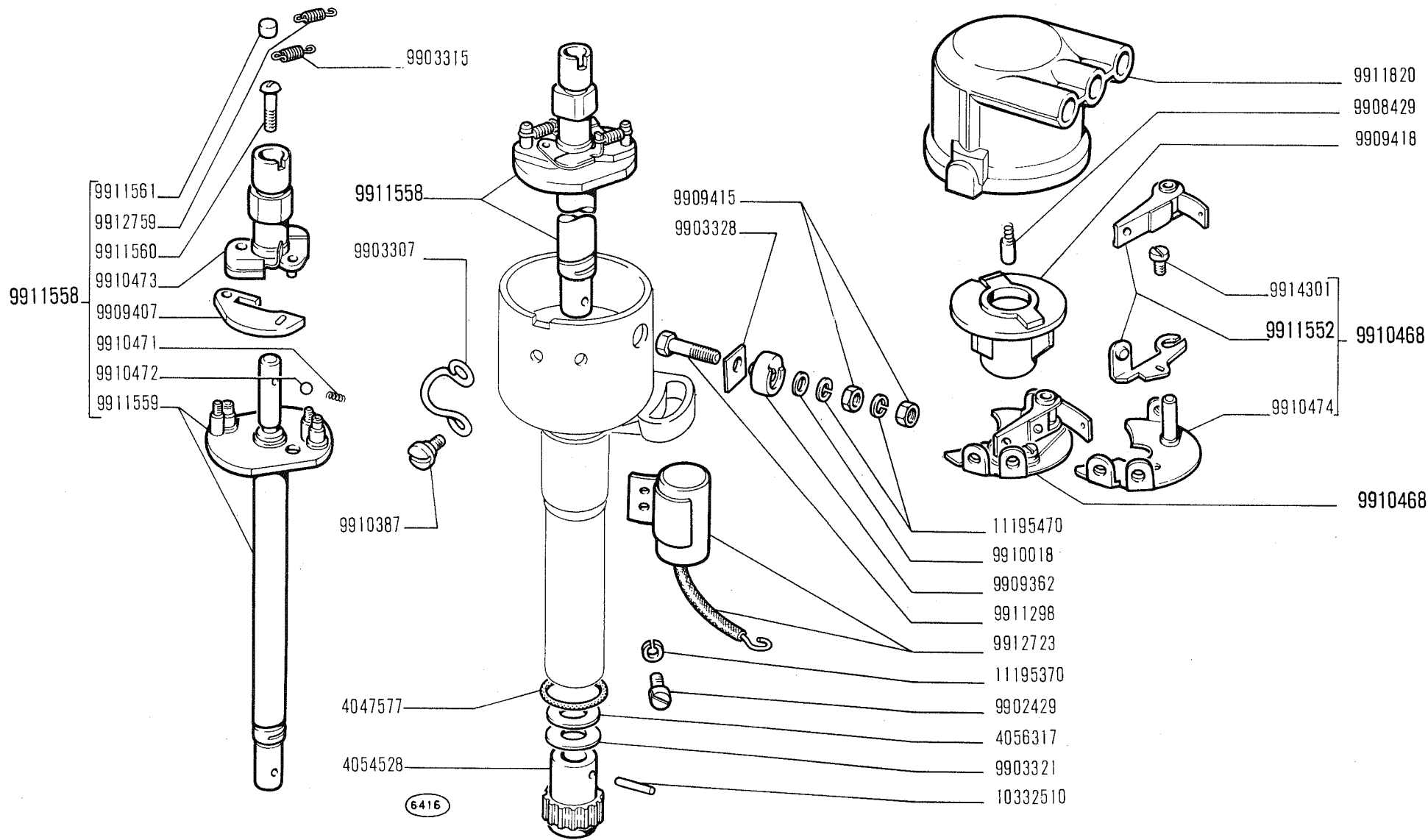

DISTRIBUTORE DI ACCENSIONE 4083137 (Marelli)

- Allumeur
- Zündverteiler

- Ignition Distributor
- Distribuidor de encendido

modif.	n. ordinaz.	quant.	Denominazione	Désignation	Benennung	Description	Denominaciones
	4047577	1	Anello tenuta	Joint	Dichtring	Seal	Junta
	4054528	1	Ingranaggio	Pignon	Zahnrad	Gear	Piñón
	4056317	1	Rosetta piana	Rondelle	Scheibe	Washer	Arandela
	9902429	1	Vite	Vis	Schraube	Screw	Tornillo
	9903307	2	Molla	Ressort	Feder	Spring	Muelle
	9903315	1	Molla	Ressort	Feder	Spring	Muelle
	9903321	—	Rosetta piana	Rondelle	Scheibe	Washer	Arandela
	9903328	1	Piastrina isolante	Plaquette	Isolierung	Plate	Placa aislante
	9908429	1	Spazzola	Balai	Kohlebürste	Brush	Escobilla
	9909362	1	Blocchetto isolante	Isolant	Isolierung	Block	Aislador
	9909407	2	Massa anticipo	Masselotte	Fliehwegicht	Weight	Contrapeso
	9909415	2	Dado	Écrou	Mutter	Nut	Tuerca
	9909418	1	Distributore rotante	Allumeur	Laufstück	Rotor	Pipa
	9910018	2	Rosetta piana	Rondelle	Scheibe	Washer	Arandela
	9910387	2	Vite	Vis	Schraube	Screw	Tornillo
	9910468	1	Ruttore compl.	Rupteur	Unterbrecher	Breaker	Ruptor
	9910471	1	Molla	Ressort	Feder	Spring	Muelle
	9910472	1	Sfera	Bille	Kugel	Ball	Bola
	9910473	1	Camma	Came	Nocken	Cam	Leva
	9910474	1	Piastra	Plaque	Platte	Plate	Placa
	9911298	1	Vite	Vis	Schraube	Screw	Tornillo
	9911552	1	Martelletto compl.	Linguet	Hammer	Arm	Martillo
	9911558	1	Albero compl.	Arbre	Welle	Shaft	Árbol
	9911559	1	Albero	Arbre	Welle	Shaft	Árbol
	9911560	1	Vite	Vis	Schraube	Screw	Tornillo
	9911561	1	Feltro	Feutre	Filz	Felt	Fieltro
	9911820	1	Calotta	Calotte	Verteilerkappe	Cap	Tapa
	9912723	1	Condensatore	Condensateur	Kondensator	Condenser	Condensador
	9912759	1	Molla	Ressort	Feder	Spring	Muelle
	9914301	1	Vite	Vis	Schraube	Screw	Tornillo
	10332510	1	Spina	Goupille	Stift	Pin	Pasador
	11195370	1	Rosetta sicurezza	Rondelle frein	Sicherungsring	Lockwasher	Arandela de freno
	11195470	2	Rosetta sicurezza	Rondelle frein	Sicherungsring	Lockwasher	Arandela de freno

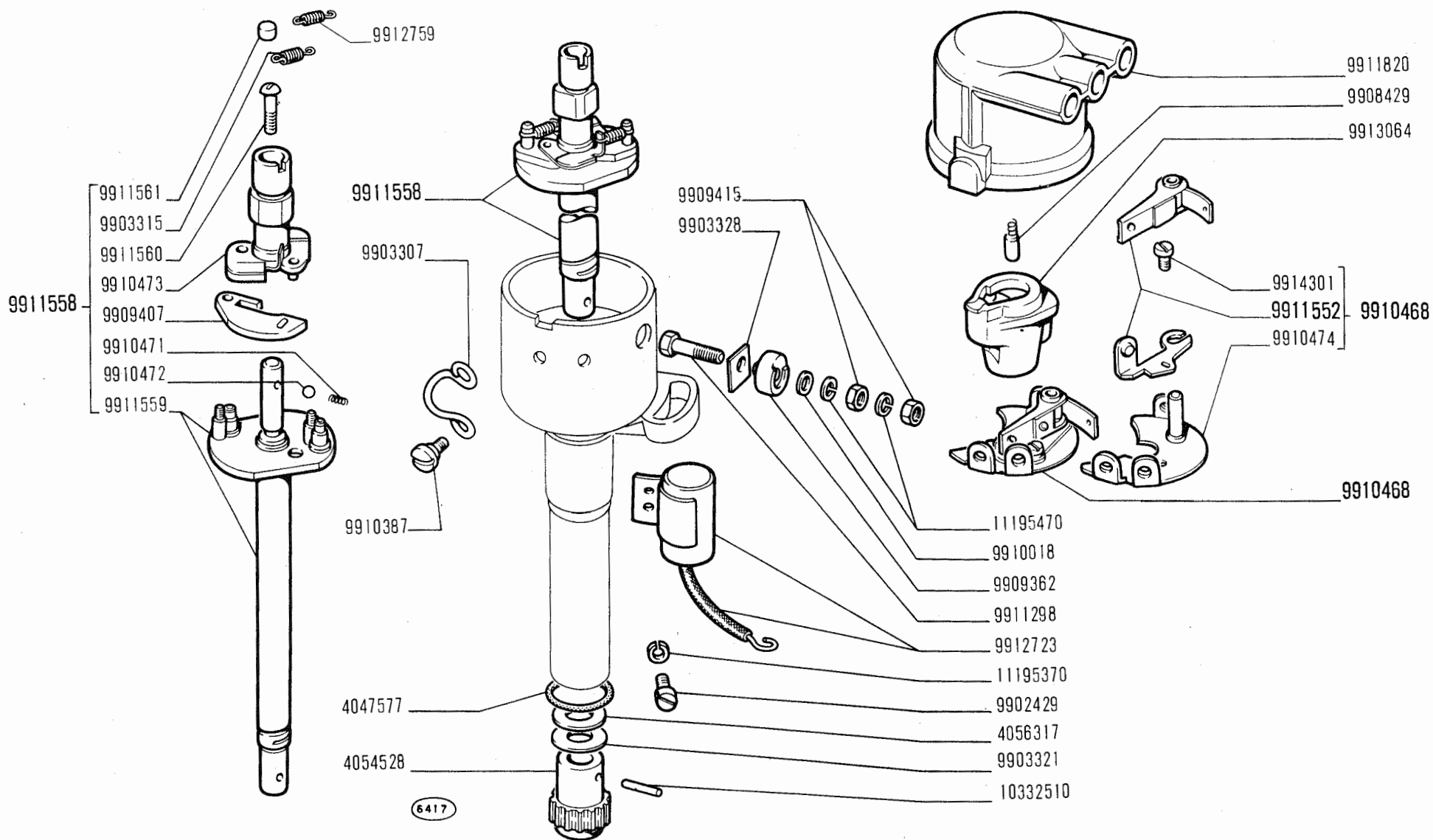

bianchina
panoramica

DISTRIBUTORE DI ACCENSIONE 4096718 (13) (Marelli)

- Allumeur
- Zündverteiler

- Ignition Distributor
- Distribuidor de encendido

F6.14/1

modif.	n. ordinaz.	quant.	Denominazione	Désignation	Benennung	Description	Denominaciones
4047577	1		Anello tenuta	Joint	Dichtring	Seal	Junta
4054528	1		Ingranaggio	Pignon	Zahnrad	Gear	Piñón
4056317	1		Rosetta piana	Rondelle	Scheibe	Washer	Arandela
9902429	1		Vite	Vis	Schraube	Screw	Tornillo
9903307	2		Molla	Ressort	Feder	Spring	Muelle
9903315	1		Molla	Ressort	Feder	Spring	Muelle
9903321	—		Rosetta piana	Rondelle	Scheibe	Washer	Arandela
9903328	1		Piastrina isolante	Plaquette	Isolierung	Plate	Placa aislante
9908429	1		Spazzola	Balai	Kohlebürste	Brush	Escobilla
9909362	1		Blocchetto isolante	Isolant	Isolierung	Block	Aislador
9909407	2		Massa anticipo	Masselotte	Fliehwicht	Weight	Contrapeso
9909415	2		Dado	Écrou	Mutter	Nut	Tuerca
9910018	2		Rosetta piana	Rondelle	Scheibe	Washer	Arandela
9910387	2		Vite	Vis	Schraube	Screw	Tornillo
9910468	1		Ruttore compl.	Rupteur	Unterbrecher	Breaker	Ruptor
9910471	1		Molla	Ressort	Feder	Spring	Muelle
9910472	1		Sfera	Bille	Kugel	Ball	Bola
9910473	1		Camma	Came	Nocken	Cam	Leva
9910474	1		Piastra	Plaque	Platte	Plate	Placa
9911298	1		Vite	Vis	Schraube	Screw	Tornillo
9911552	1		Martelletto compl.	Linguet	Hammer	Arm	Martillo
9911558	1		Albero compl.	Arbre	Welle	Shaft	Árbol
9911559	1		Albero	Arbre	Welle	Shaft	Árbol
9911560	1		Vite	Vis	Schraube	Screw	Tornillo
9911561	1		Feltro lubrificazione	Mèche	Schmierdocht	Wick	Fieltro
9911820	1		Calotta	Calotte	Verteilerkappe	Cap	Tapa
9912723	1		Condensatore	Condensateur	Kondensator	Condenser	Condensador
9912759	1		Molla	Ressort	Feder	Spring	Muelle
9913064	1		Distributore rotante	Allumeur	Laufstück	Rotor	Pipa
9914301	1		Vite	Vis	Schraube	Screw	Tornillo
10332510	1		Spina	Goupille	Stift	Pin	Pasador
11195370	1		Rosetta sicurezza	Rondelle frein	Sicherungsring	Lockwasher	Arandela de freno
11195470	2		Rosetta sicurezza	Rondelle	Sicherungsring	Lockwasher	Arandela de freno

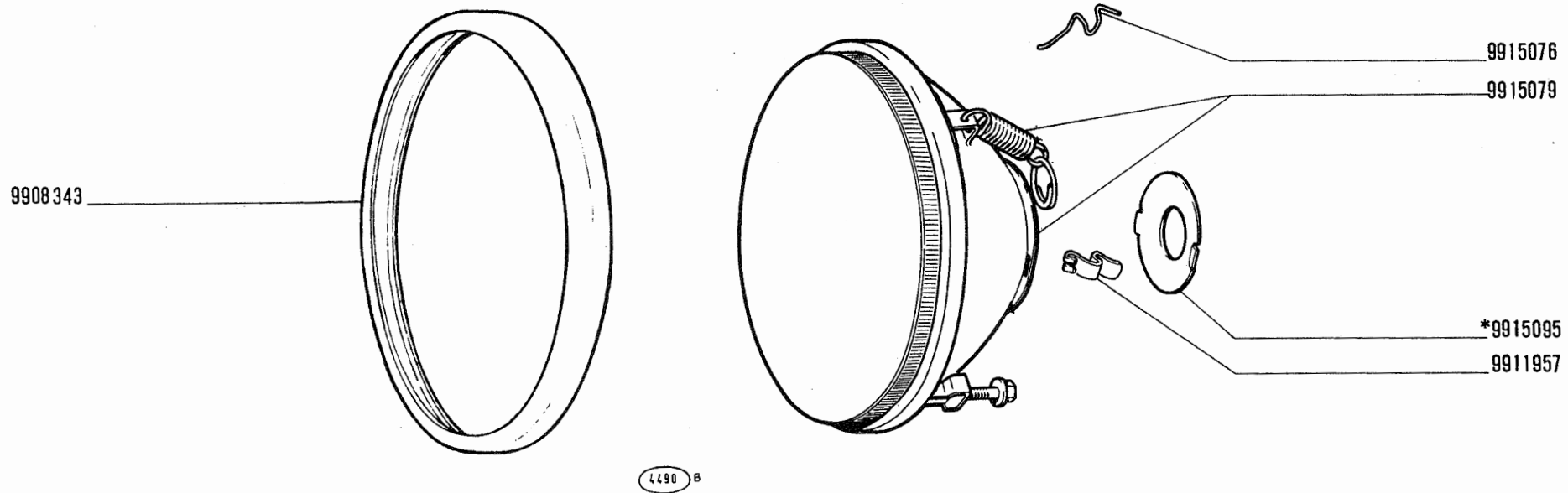

* Vedere elenco - Voir la liste - See list - Siehe Liste - Véase la lista

blanchina
panoramica
 e derivati

PROIETTORE 111167 (Siem)

- Projecteur
- Scheinwerfer

- Headlamp
- Projector

F6.29

modif.	n. ordinaz.	quant.	Denominazione	Désignation	Benennung	Description	Denominaciones
	9908343	1	Cornice	Monture	Rahmen	Frame	Marco
	9911957	2	Molla	Agrafe	Klemmstück	Clip	Sujetador
	9915076	4	Molla	Agrafe	Klemmstück	Clip	Sujetador
	9915079	1	Gruppo ottico	Groupe optique	Einsatz	Lens/reflector	Grupo óptico
	9915095	1	Disco (*)	Disque (*)	Scheibe (*)	Plate (*)	Disco (*)
			(*) Non fornito col complessivo.	(*) Pas livré avec l'ensemble.	(*) Nicht mit Zusammenbau lieferbar.	(*) Not supplied with the assy.	(*) No se provee con el conjunto.

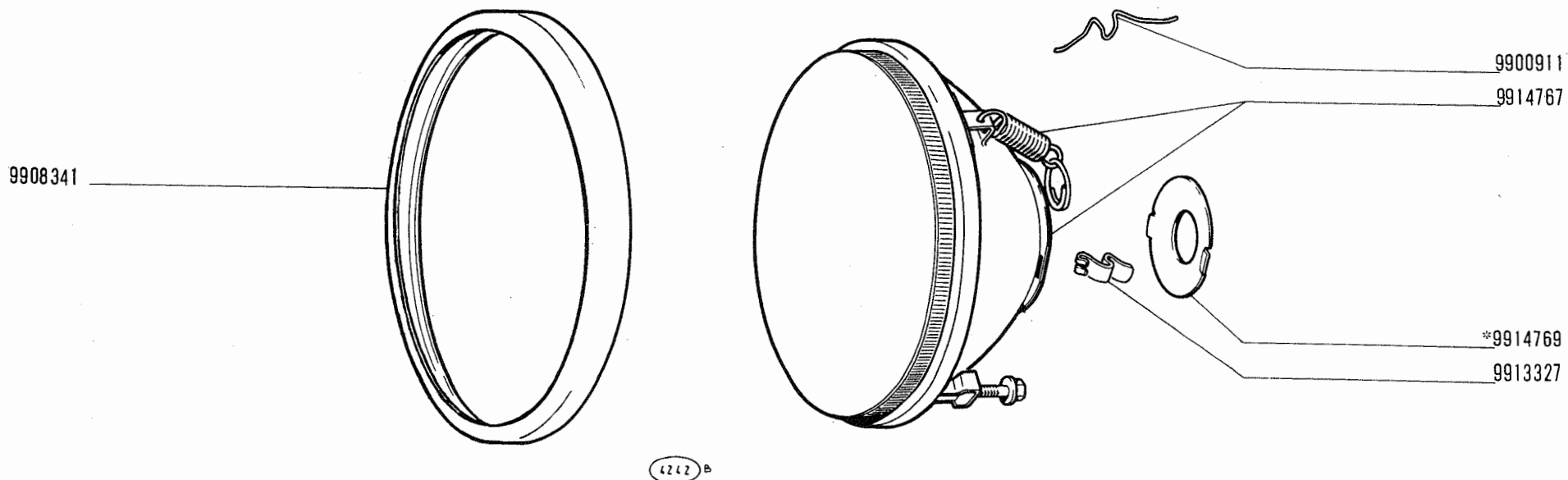

* vedere elenco -voir la liste -siehe Liste -see list -véase la lista

bianchina
panoramica
 e derivati

PROIETTORE 111168 (Carello)

- Projecteur
- Scheinwerfer

- Headlamp
- Projector

F6.29/1

modif.	n. ordinaz.	quant.	Denominazione	Désignation	Benennung	Description	Denominaciones
9900911	4		Molla	Agrafe	Klemmstück	Clip	Sujetador
9908341	1		Cornice	Monture	Rahmen	Frame	Marco
9913327	2		Molla	Agrafe	Klemmstück	Clip	Sujetador
9914767	1		Gruppo ottico	Groupe optique	Einsatz	Lens/reflector	Grupo óptico
9914769	1		Disco (*)	Disque (*)	Scheibe (*)	Plate (*)	Disco (*)
			(*) Non fornito col complessivo.	(*) Pas livré avec l'ensemble.	(*) Nicht mit Zusammenbau lieferbar.	(*) Not supplied with the assy.	(*) No se provee con el conjunto.

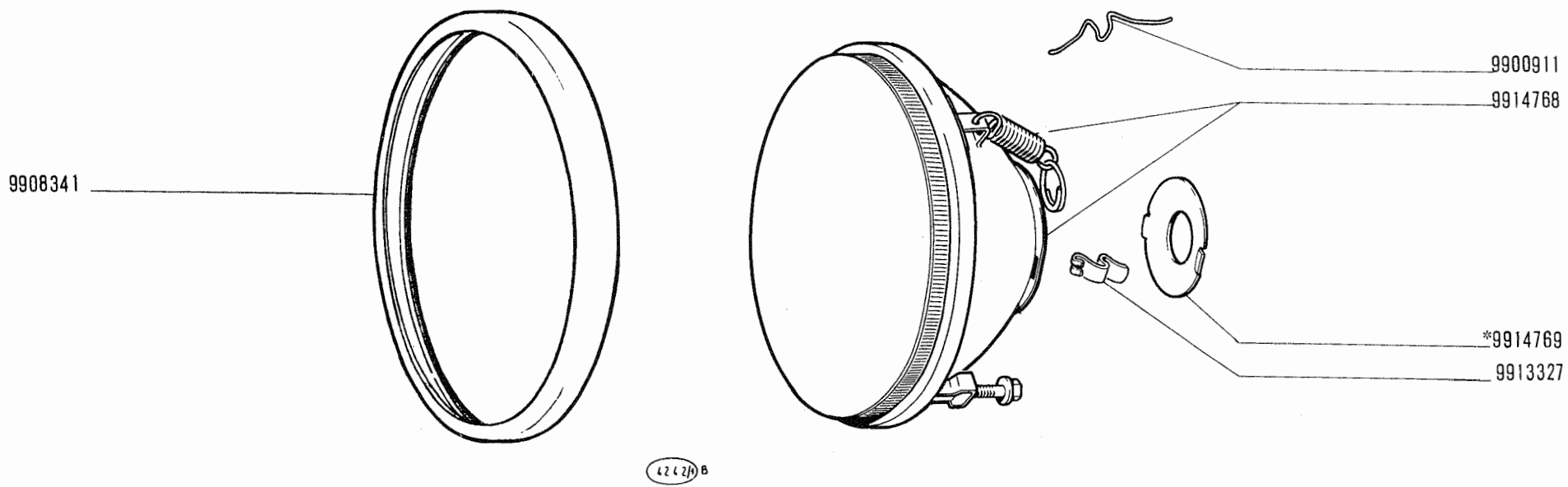

* vedere elenco -voir la liste -siehe Liste -see list véase la lista

bianchina
panoramica
 e derivati

PROIETTORE 111175 (11) (Carello)

- Projecteur
- Scheinwerfer

- Headlamp
- Projector

F6.29/2

modif.	n. ordinaz.	quant.	Denominazione	Désignation	Benennung	Description	Denominaciones
9900911	4		Molla	Agrafe	Klemmstück	Clip	Sujetador
9908341	1		Cornice	Monture	Rahmen	Frame	Marco
9913327	2		Molla	Agrafe	Klemmstück	Clip	Sujetador
9914768	1		Gruppo ottico	Groupe optique	Einsatz	Lens/reflector	Grupo óptico
9914769	1		Disco (*)	Disque (*)	Scheibe (*)	Plate (*)	Disco (*)
			(*) Non fornito col complessivo.	(*) Pas livré avec l'ensemble	(*) Nicht mit Zusammenbau lieferbar	(*) Not supplied with the assy.	(*) No se provee con el conjunto

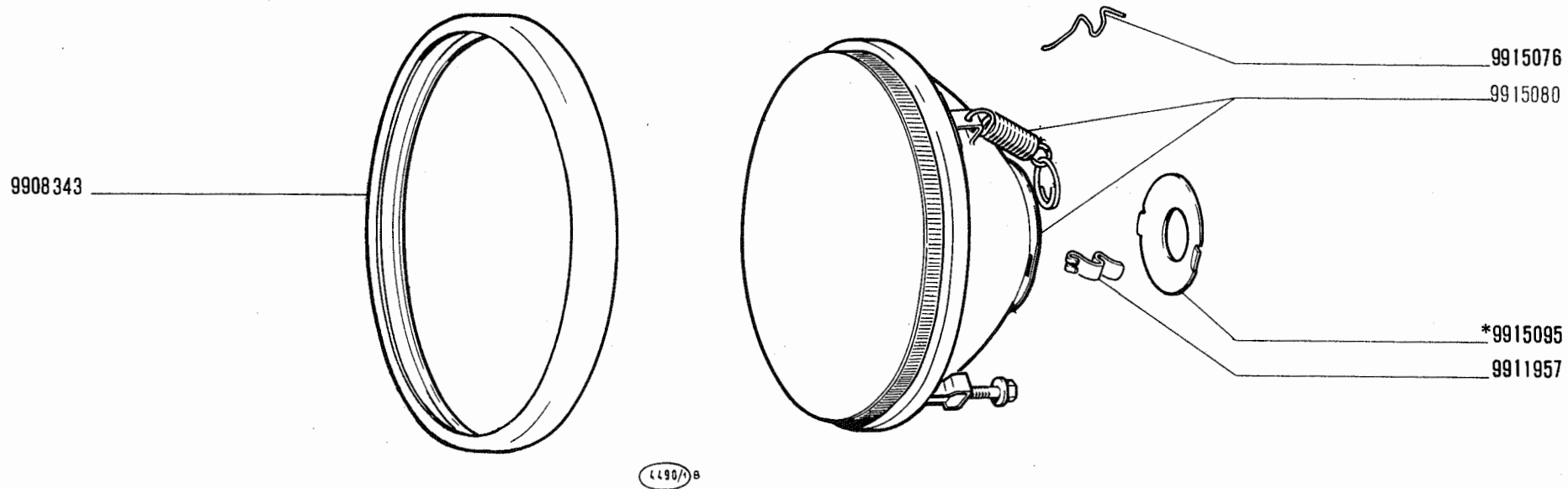

* Vedere elenco -Voir la liste -See list -Siehe Liste -Véase la lista

bianchina
panoramica
derivati

PROIETTORE 111176 (11) (Siem)

- Projecteur
- Scheinwerfer
- Headlamp
- Projector

F6.29/3

modif.	n. ordinaz.	quant.	Denominazione	Désignation	Benennung	Description	Denominaciones
	9908343	1	Cornice	Monture	Rahmen	Frame	Marco
	9911957	2	Molla	Agrafe	Klemmstück	Clip	Sujetador
	9915076	4	Molla	Agrafe	Klemmstück	Clip	Sujetador
	9915080	1	Gruppo ottico	Groupe optique	Einsatz	Lens/reflector	Grupo óptico
	9915095	1	Disco (*)	Disque (*)	Scheibe (*)	Plate (*)	Disco (*)
			(*) Non fornito col complessivo.	(*) Pas livré avec l'ensemble	(*) Nicht mit Zusammenbau lieferbar	(*) Not supplied with the assy.	(*) No se provee con el conjunto

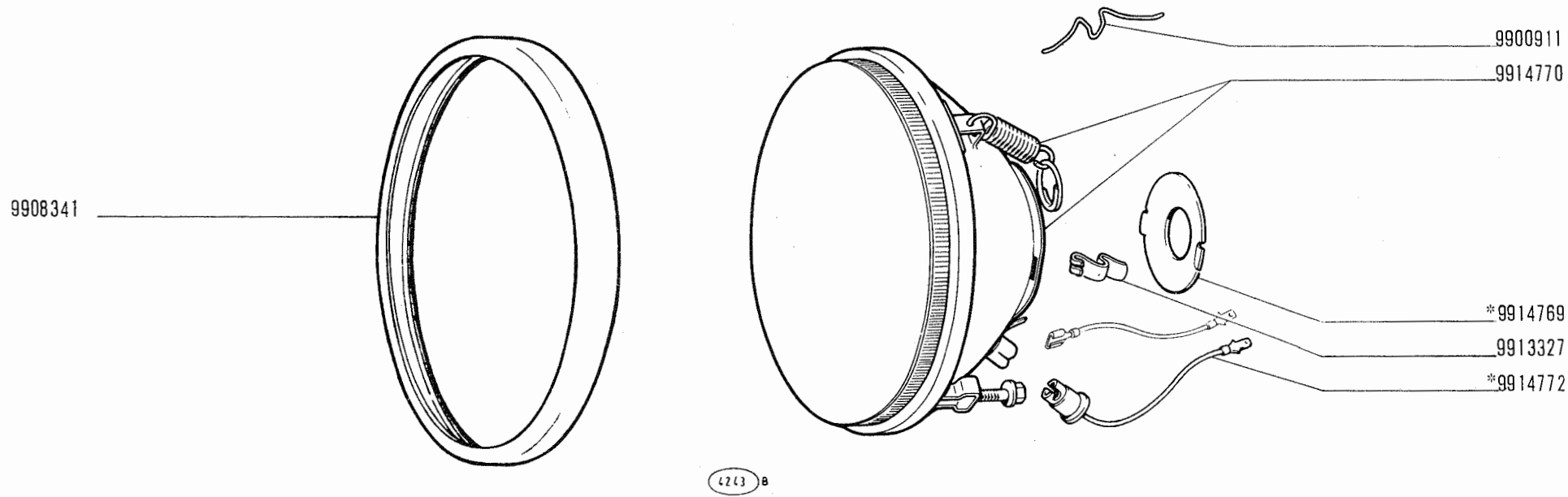

*vedere elenco -voir la liste -siehe Liste -see list -véase la lista

bianchina
panoramica
e derivati

PROIETTORE 1111177 (12) (Carello)

- Projecteur
- Scheinwerfer

- Headlamp
- Projector

F6.29/4

modif.	n. ordinaz.	quant.	Denominazione	Désignation	Benennung	Description	Denominaciones
9900911	4		Molla	Agrafe	Klemmstück	Clip	Sujetador
9908341	1		Cornice	Monture	Rahmen	Frame	Marco
9913327	2		Molla	Agrafe	Klemmstück	Clip	Sujetador
9914769	1		Disco (*)	Disque (*)	Scheibe (*)	Plate (*)	Disco (*)
9914770	1		Gruppo ottico	Groupe optique	Einsatz	Lens/reflector	Grupo óptico
9914772	1		Portalamпада (*)	Porte-lampe (*)	Lampenfassung (*)	Bulb holder (*)	Portalámpara (*)
			(*) Non fornito col complessivo.	(*) Pas livré avec l'ensemble.	(*) Nicht mit Zusammenbau lieferbar.	(*) Not supplied with the assy.	(*) No se provee con el conjunto.

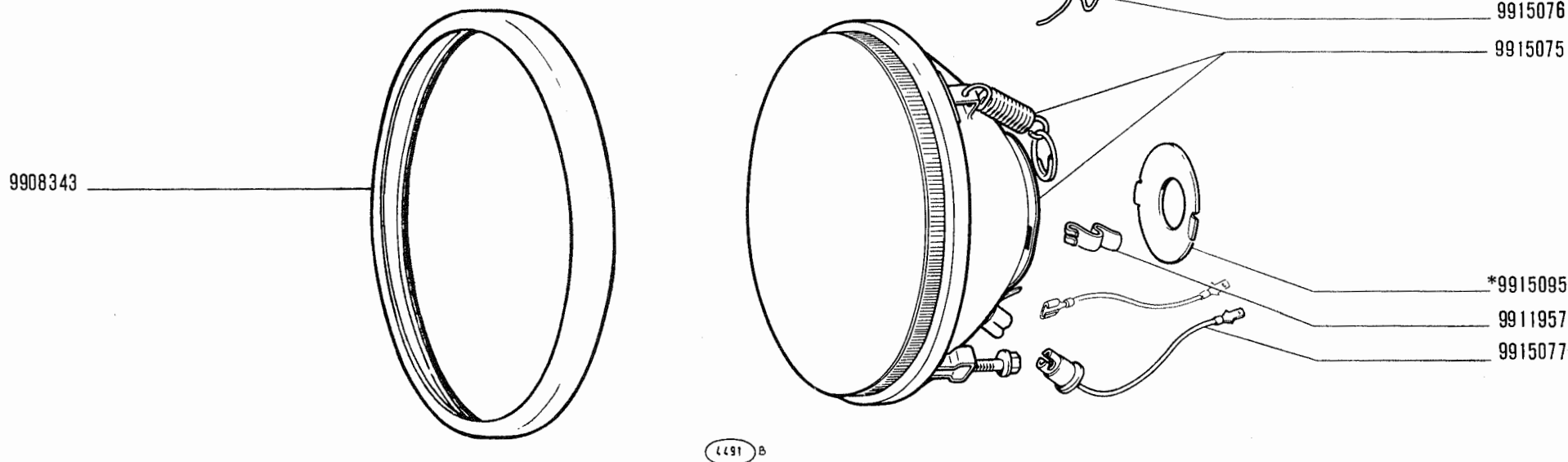

* Vedere elenco - Voir la liste - See list - Siehe Liste - Véase la lista

bianchina
panoramica
 e derivati

PROIETTORE 111178 (12) (Siem)

- Projecteur
- Scheinwerfer

- Headlamp
- Projector

F6.29/5

modif.	n. ordinaz.	quant.	Denominazione	Désignation	Benennung	Description	Denominaciones
	9908343	1	Cornice	Monture	Rahmen	Frame	Marco
	9911957	2	Molla	Agrafe	Klemmstück	Clip	Sujetador
	9915075	1	Gruppo ottico	Groupe optique	Einsatz	Lens/reflector	Grupo óptico
	9915076	4	Molla	Agrafe	Klemmstück	Clip	Sujetador
	9915077	1	Portalampada	Porte-lampe	Lampenfassung	Bulb holder	Portalámpara
	9915095	1	Disco (*)	Disque (*)	Scheibe (*)	Plate (*)	Disco (*)
			(*) Non fornito col complessivo.	(*) Pas livré avec l'ensemble.	(*) Nicht mit Zusammenbau lieferbar.	(*) Not supplied with the assy.	(*) No se provee con el conjunto.

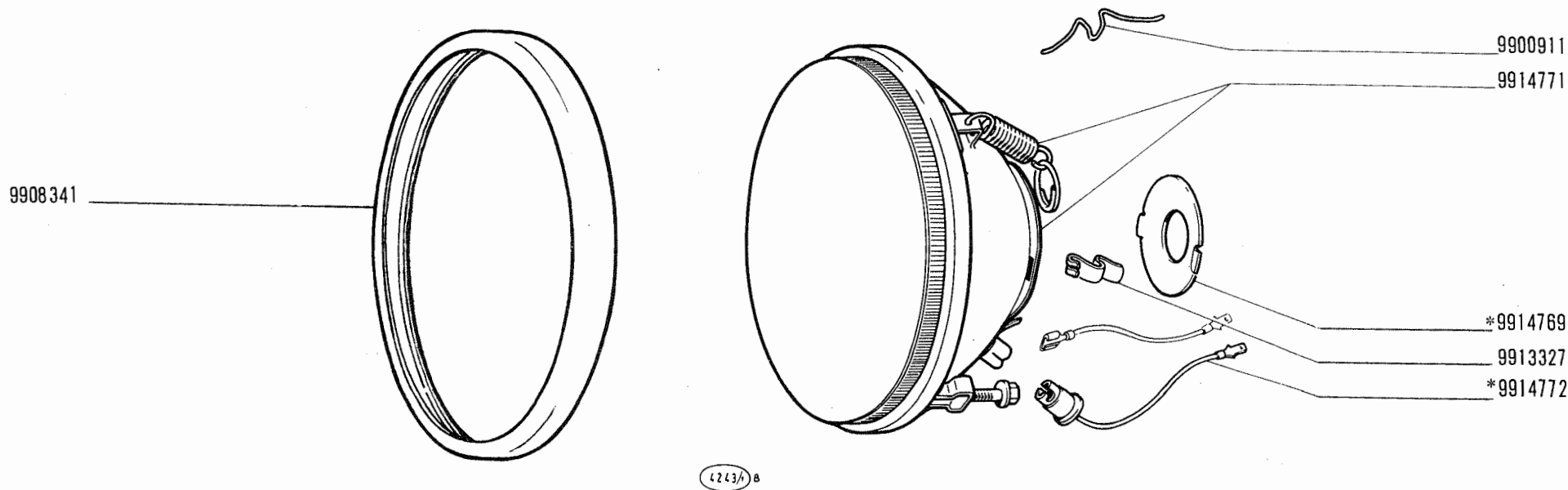

* vedere elenco -voir la liste -siehe Liste -see list -véase la lista

blanchina
panoramica
e derivati

PROIETTORE 111179 (15) (Carello)

- Projecteur
- Scheinwerfer

- Headlamp
- Projector

F6.29/6

modif.	n. ordinaz.	quant.	Denominazione	Désignation	Benennung	Description	Denominaciones
9900911	4		Molla	Agrafe	Klemmstück	Clip	Sujetador
9908341	1		Cornice	Monture	Rahmen	Frame	Marco
9913327	2		Molla	Agrafe	Klemmstück	Clip	Sujetador
9914769	1		Disco (*)	Disque (*)	Scheibe (*)	Plate (*)	Disco (*)
9914771	1		Gruppo ottico	Groupe optique	Einsatz	Lens/reflector	Grupo óptico
9914772	1		Portalamпада (*)	Porte-lampe (*)	Lampenfassung (*)	Bulb holder (*)	Portalámpara (*)
			(*) Non fornito col complessivo.	(*) Pas livré avec l'ensemble.	(*) Nicht mit Zusammenbau lieferbar.	(*) Not supplied with the assy.	(*) No se provee con el conjunto.

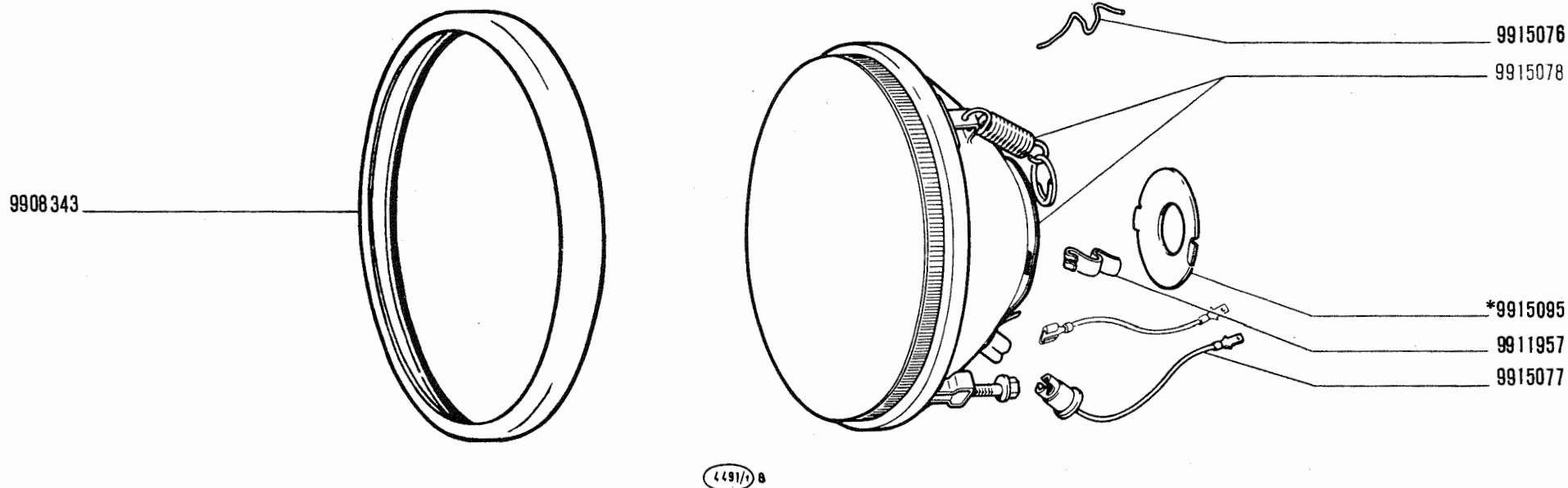

* Vedere elenco - Voir la liste - See list - Siehe Liste - Véase la lista

bianchina
panoramica
e derivati

PROIETTORE 111180 (15) (Siem)

- Projecteur
- Scheinwerfer

- Headlamp
- Projector

F6.29/7

modif.	n. ordinaz.	quant.	Denominazione	Désignation	Benennung	Description	Denominaciones
	9908343	1	Cornice	Monture	Rahmen	Frame	Marco
	9911957	2	Molla	Agrafe	Klemmstück	Clip	Sujetador
	9915076	4	Molla	Agrafe	Klemmstück	Clip	Sujetador
	9915077	1	Portalampada	Porte-lampe	Lampenfassung	Bulb holder	Portalámpara
	9915078	1	Gruppo ottico	Groupe optique	Einsatz	Lens/reflector	Grupo óptico
	9915095	1	Disco (*)	Disque (*)	Scheibe (*)	Plate (*)	Disco (*)
			(*) Non fornito col complessivo.	(*) Pas livré avec l'ensemble.	(*) Nicht mit Zusammenbau lieferbar.	(*) Not supplied with the assy.	(*) No se provee con el conjunto.

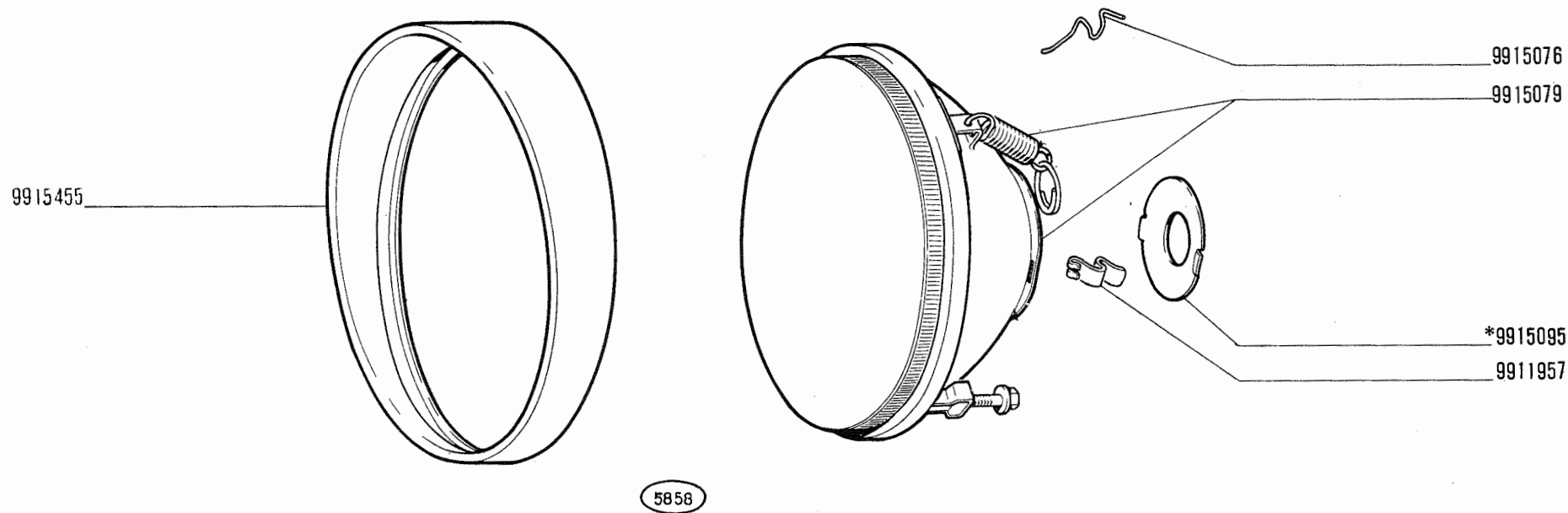

* vedere elenco -voir la liste -siehe Tabelle-see list -véase la lista

bianchina
panoramica
 e derivati

PROIETTORE 4136923 (Siem)

- Projecteur
- Scheinwerfer

- Headlamp
- Projector

F6.29/9

modif.	n. ordinaz.	quant.	Denominazione	Désignation	Benennung	Description	Denominaciones
9911957	2		Molla	Agrafe	Klemmstück	Clip	Sujetador
9915076	4		Molla	Agrafe	Klemmstück	Clip	Sujetador
9915079	1		Gruppo ottico	Groupe optique	Einsatz	Lens/reflector	Grupo óptico
9915095	1		Disco (*)	Disque (*)	Scheibe (*)	Plate (*)	Disco (*)
9915455	1		Cornice	Monture	Rahmen	Frame	Marco
			(*) Non fornito col complessivo.	(*) Pas livré avec l'ensemble	(*) Nicht mit Zusammenbau lieferbar	(*) Not supplied with the assy.	(*) No se provee con el conjunto

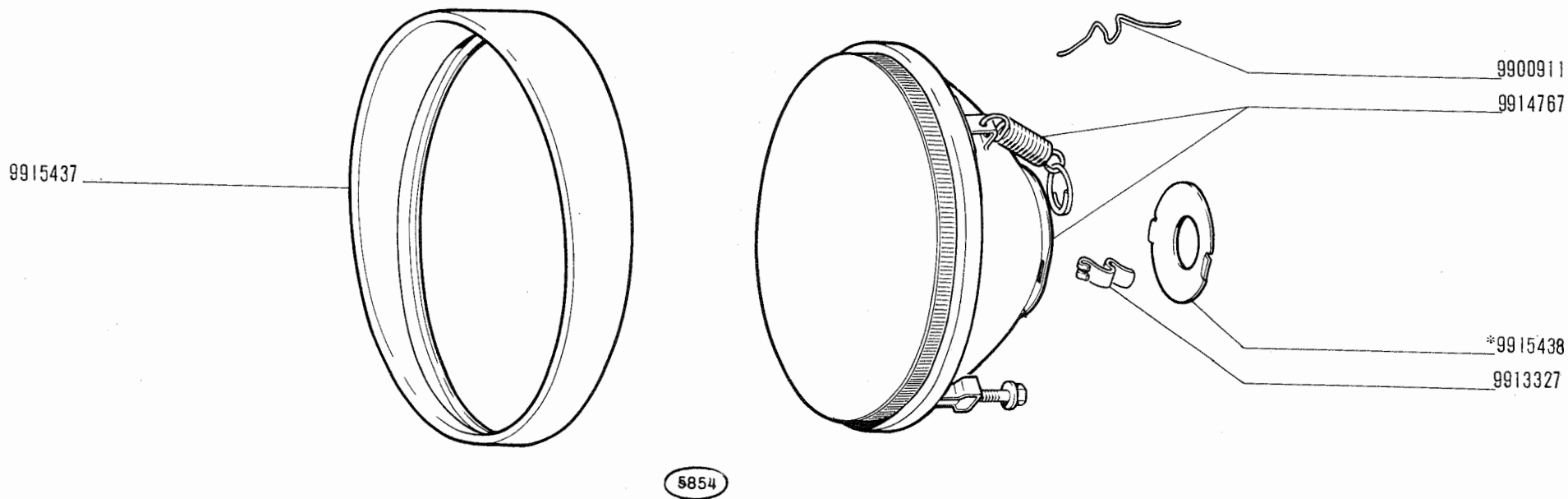

* vedere elenco -voir la liste -siehe Tabelle -see list -véase la lista

bianchina
panoramica
e derivati

PROIETTORE 4136924 (Carello)

- Projecteur
- Scheinwerfer

- Headlamp
- Projector

F6.29/10

modif.	n. ordinaz.	quant.	Denominazione	Désignation	Benennung	Description	Denominaciones
9900911	4		Molla	Agrafe	Klemmstück	Clip	Sujetador
9913327	2		Molla	Agrafe	Klemmstück	Clip	Sujetador
9914767	1		Gruppo ottico	Groupe optique	Einsatz	Lens/reflector	Grupo óptico
9915437	1		Cornice	Monture	Rahmen	Frame	Marco
9915438	1		Disco (*)	Disque (*)	Scheibe (*)	Plate (*)	Disco (*)
			(*) Non fornito col complessivo.	(*) Pas livré avec l'ensemble	(*) Nicht mit Zusammenbau lieferbar	(*) Not supplied with the assy.	(*) No se provee con el conjunto

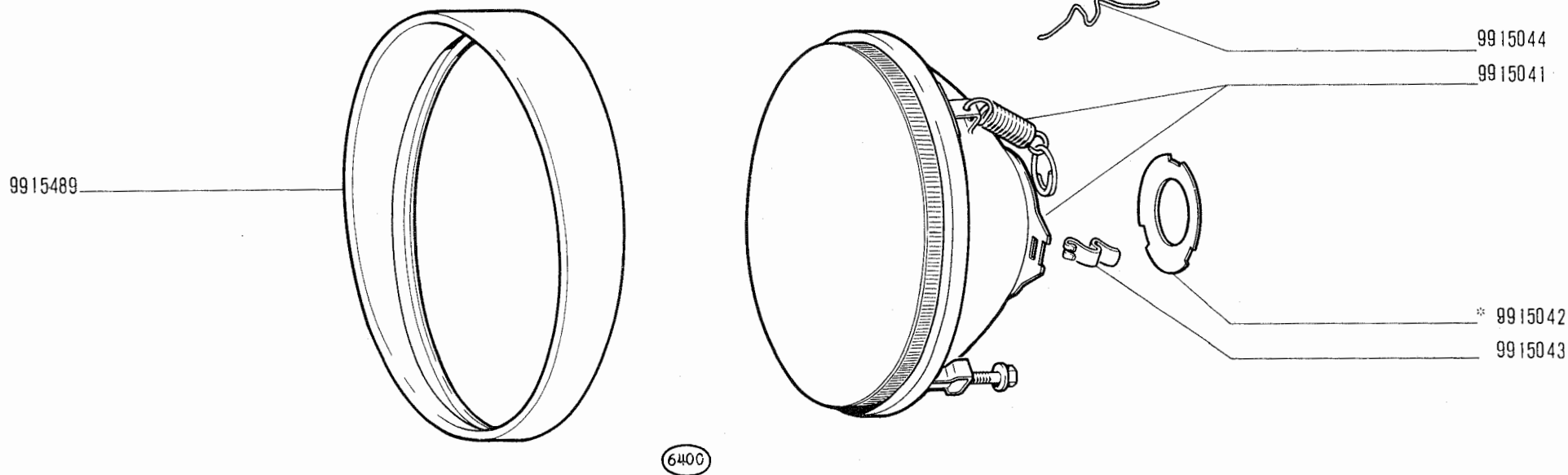

* Vedere elenco - Voir la liste - See list - Siehe Liste - Véase la lista

bianchina
panoramica
 e derivati

PROIETTORE 4136925 (Elma)

- Projecteur
- Scheinwerfer

- Headlamp
- Projector

F6.29/11

modif.	n. ordinaz.	quant.	Denominazione	Désignation	Benennung	Description	Denominaciones
9915041	1		Gruppo ottico	Groupe optique	Einsatz	Lens/reflector	Grupo óptico
9915042	1		Disco (*)	Disque (*)	Scheibe (*)	Plate (*)	Disco (*)
9915043	2		Molla	Agrafe	Klemmstück	Clip	Sujetador
9915044	4		Molla	Agrafe	Klemmstück	Clip	Sujetador
9915489	1		Cornice	Monture	Rahmen	Frame	Marco
			(*) Non fornito col complessivo.	(*) Pas livré avec l'ensemble	(*) Nicht mit Zusammenbau lieferbar	(*) Not supplied with the assy.	(*) No se provee con el conjunto

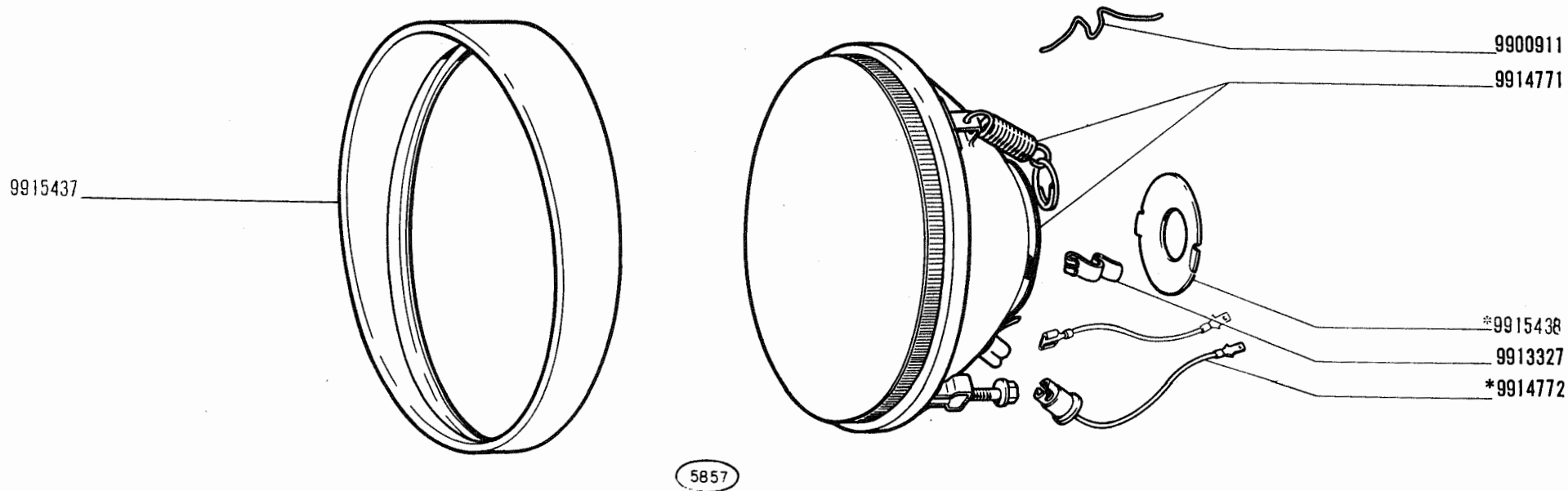

* vedere elenco -voir la liste -siehe Tabelle -see list -véase la lista

bianchina
panoramica
 e derivati

PROIETTORE 4136927 (15) (Carello)

- Projecteur
- Scheinwerfer

- Headlamp
- Projector

F6.29/12

modif.	n. ordinaz.	quant.	Denominazione	Désignation	Benennung	Description	Denominaciones
9900911	4		Molla	Agrafe	Klemmstück	Clip	Sujetador
9913327	2		Molla	Agrafe	Klemmstück	Clip	Sujetador
9914771	1		Gruppo ottico	Groupe optique	Einsatz	Lens/reflector	Grupo óptico
9914772	1		Portalamпада (*)	Porte-lampe (*)	Lampenfassung (*)	Bulb holder (*)	Portalámpara (*)
9915437	1		Cornice	Monture	Rahmen	Frame	Marco
9915438	1		Disco (*)	Disque (*)	Scheibe (*)	Plate (*)	Disco (*)
			(*) Non fornito col complessivo.	(*) Pas livré avec l'ensemble	(*) Nicht mit Zusammenbau lieferbar	(*) Not supplied with the assy.	(*) No se provee con el conjunto

9915437

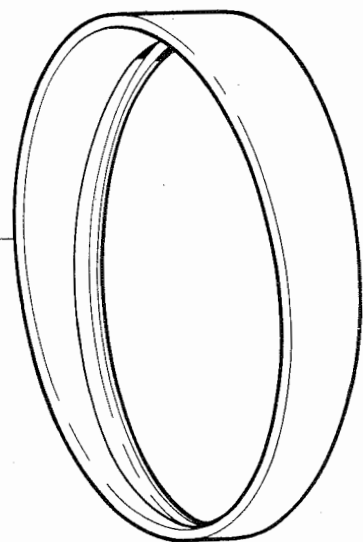

5856

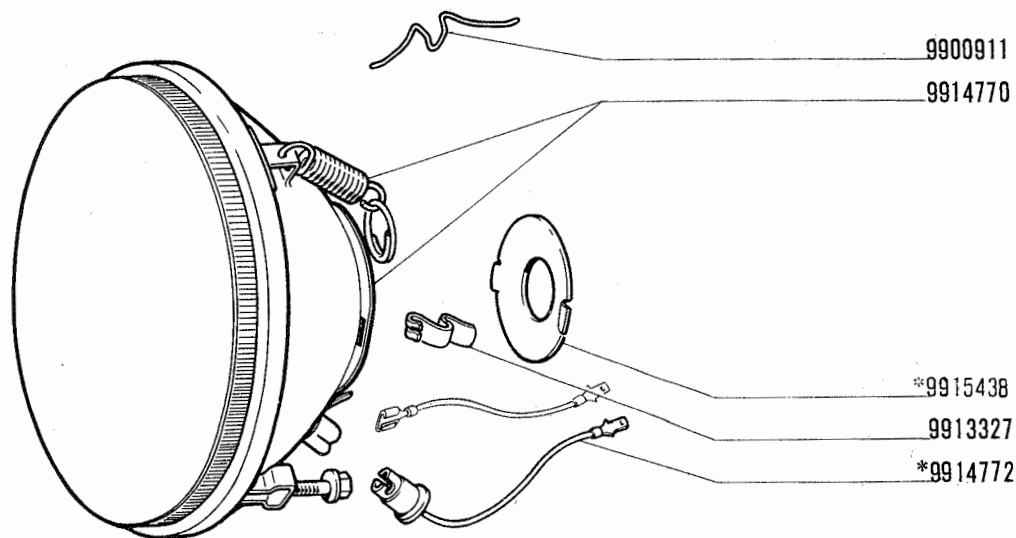

*vedere elenco -voir la liste -siehe Tabelle -see list -véase la lista

blanchina
panoramica

PROIETTORE 4136929 (12) (Carello)

- Projecteur
- Scheinwerfer

- Headlamp
- Projector

F6.29/13

modif.	n. ordinaz.	quant.	Denominazione	Désignation	Benennung	Description	Denominaciones
	9900911	4	Molla	Agrafe	Klemmstück	Clip	Sujetador
	9913327	2	Molla	Agrafe	Klemmstück	Clip	Sujetador
	9914770	1	Gruppo ottico	Groupe optique	Einsatz	Lens/reflector	Grupo óptico
	9914772	1	Portalamпада (*)	Porte-lampe (*)	Lampenfassung (*)	Bulb holder (*)	Portalámpara (*)
	9915437	1	Cornice	Monture	Rahmen	Frame	Marco
	9915438	1	Disco (*)	Disque (*)	Scheibe (*)	Plate (*)	Disco (*)
			(*) Non fornito col complessivo.	(*) Pas livré avec l'ensemble	(*) Nicht mit Zusammenbau lieferbar	(*) Not supplied with the assy.	(*) No se provee con el conjunto

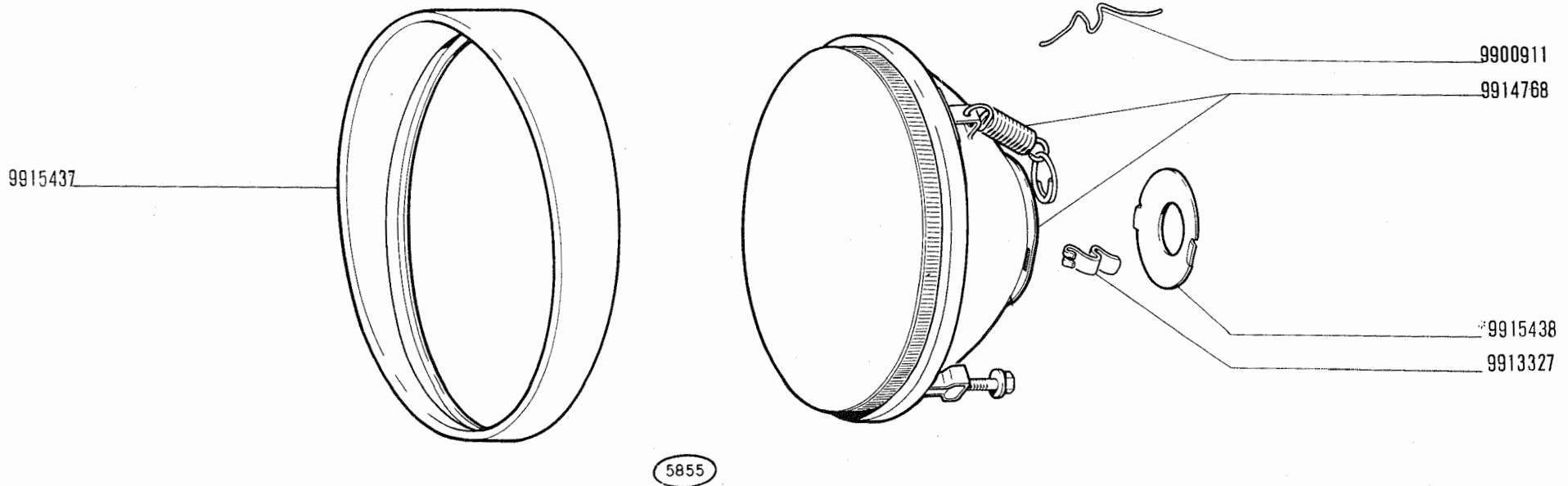

* vedere elenco -voir la liste -siehe Tabelle -see list véase la lista

bianchina
panoramica
e derivati

PROIETTORE 4136931 (11) (Carello)

- Projecteur
- Scheinwerfer

- Headlamp
- Projector

F6.29/14

modif.	n. ordinaz.	quant.	Denominazione	Désignation	Benennung	Description	Denominaciones
9900911	4		Molla	Agrafe	Klemmstück	Clip	Sujetador
9913327	2		Molla	Agrafe	Klemmstück	Clip	Sujetador
9914768	1		Gruppo ottico	Groupe optique	Einsatz	Lens/reflector	Grupo óptico
9915437	1		Cornice	Monture	Rahmen	Frame	Marco
9915438	1		Disco (*)	Disque (*)	Scheibe (*)	Plate (*)	Disco (*)
			(*) Non fornito col complessivo.	(*) Pas livré avec l'ensemble	(*) Nicht mit Zusammenbau lieferbar	(*) Not supplied with the assy.	(*) No se provee con el conjunto

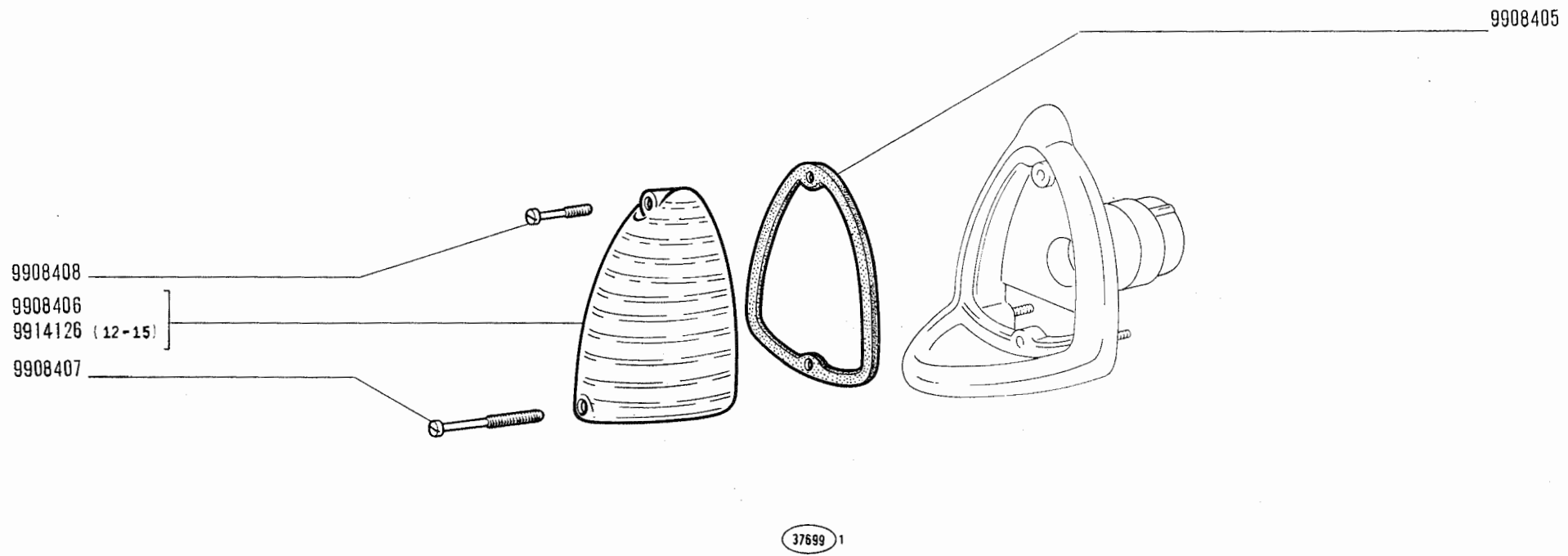

bianchina
panoramica

FANALE ANTERIORE 1104621, 1107434 (12) (15) (Giuntini)

- Lanterne AV
- Vordere Leuchte

- Front Lamp
- Lâmpara anterior

F6.32

modif.	n. ordinaz.	quant.	Denominazione	Désignation	Benennung	Description	Denominaciones
	9908405	1	Guarnizione	Joint	Dichtung	Gasket	Junta
	9908406	1	Trasparente	Transparent	Lichtscheibe	Lens	Tapa translúcida
	9908407	2	Vite lunga	Vis	Schraube	Screw	Tornillo
	9908408	2	Vite corta	Vis	Schraube	Screw	Tornillo
	9914126	1	Trasparente - 12 - 15 -	Transparent	Lichtscheibe	Lens	Tapa translúcida

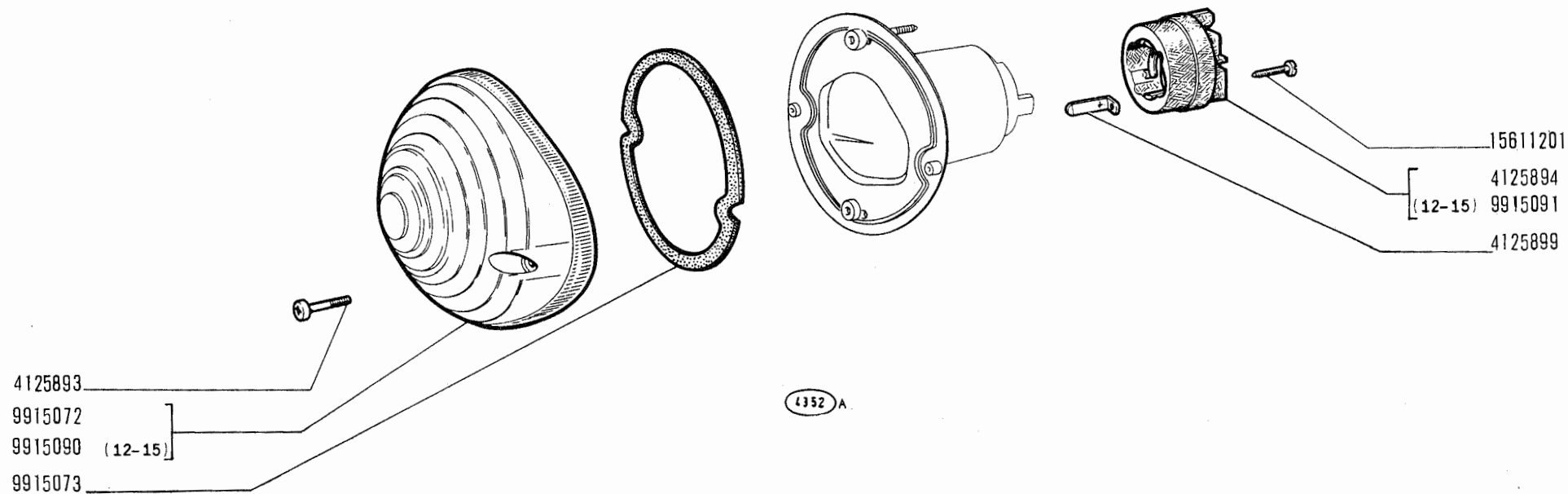

blanchina
panoramica
e derivati

FANALE ANTERIORE 4124786-4126068 (12-15) Stars

- Lanterne AV
- Vordere Leuchte

- Front Lamp
- Lámpara anterior

F6.32/1

modif.	n. ordinaz.	quant.	Denominazione	Désignation	Benennung	Description	Denominaciones
	4125893	2	Vite	Vis	Schraube	Screw	Tornillo
	4125894	1	Blocchetto connessione	Plaque de jonction	Anschlussdose	Terminal block	Caja de empalme
	4125899	2	Lamella	Plaque	Kontaktplatte	Contact plate	Placa de contacto
	9915072	1	Trasparente	Transparent	Lichtscheibe	Lens	Tapa translúcida
	9915073	1	Guarnizione	Joint	Dichtung	Gasket	Junta
	9915090	1	Trasparente - 12 - 15 -	Transparent	Lichtscheibe	Lens	Tapa translúcida
	9915091	1	Blocchetto connessione - 12 - 15 -	Plaque de jonction	Anschlussdose	Terminal block	Caja de empalme
	15611201	2	Vite	Vis	Schraube	Screw	Tornillo

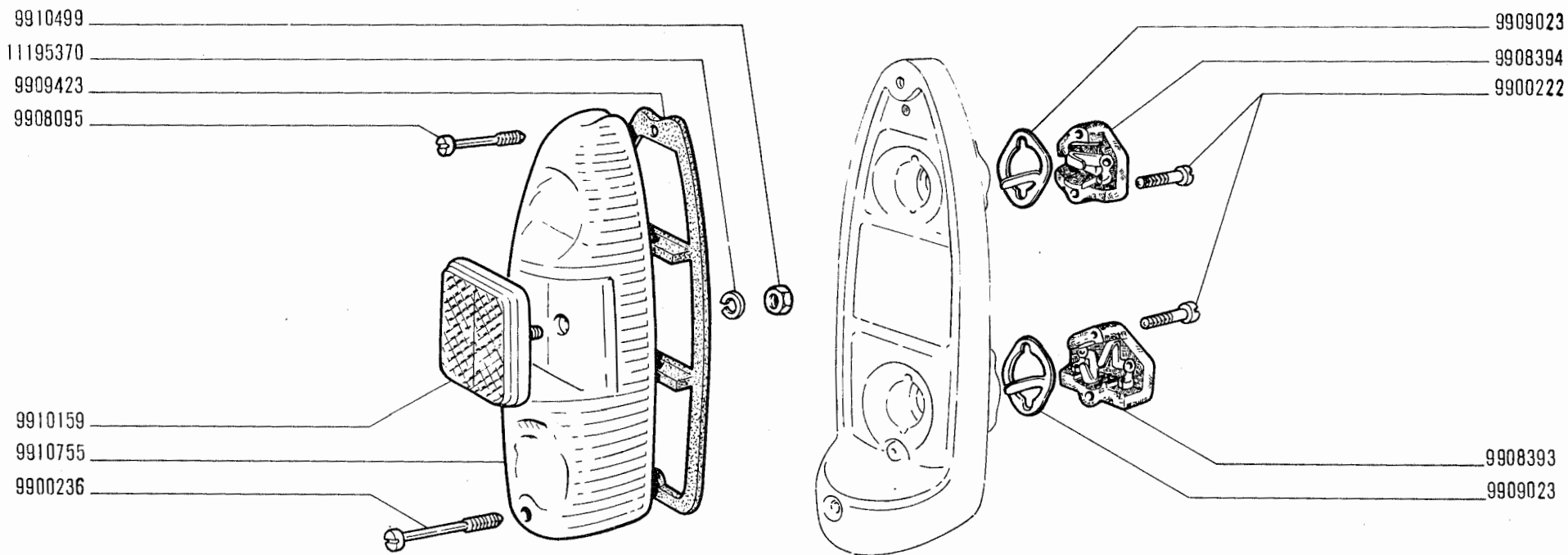

C 4388 → Vett.n. 122605 (01-02) - Vett.n. 122611 (03-04)

bianchina
panoramica
e derivati

FANALE POSTERIORE 1104624 (01-02-03-04) (Altissimo)

- Lanterne AR
- Schlussleuchte

- Tail Lamp
- Lámpara posterior

F6.34

modif.	n. ordinaz.	quant.	Denominazione	Désignation	Benennung	Description	Denominaciones
	9900222	4	Vite	Vis	Schraube	Screw	Tornillo
	9900236	1	Vite	Vis	Schraube	Screw	Tornillo
	9908095	1	Vite	Vis	Schraube	Screw	Tornillo
	9908393	1	Blocchetto per serrafili	Plaque de jonction	Anschlussdose	Terminal block	Placa de empalme
	9908394	1	Blocchetto per serrafili	Plaque de jonction	Anschlussdose	Terminal block	Placa de empalme
	9909023	2	Piastrina contatto massa	Plaquette de masse	Kontaktplatte	Contact plate	Placa de masa
	9909423	1	Guarnizione	Joint	Dichtung	Gasket	Junta
	9910159	1	Catadiottro	Catadioptré	Rückstrahler	Reflex reflector	Catafaros
	9910499	1	Dado	Écrou	Mutter	Nut	Tuerca
	9910755	1	Trasparente	Transparent	Lichtscheibe	Lens	Tapa translúcida
	11195370	1	Rosetta sicurezza	Rondelle frein	Sicherungsring	Lockwasher	Arandela de freno

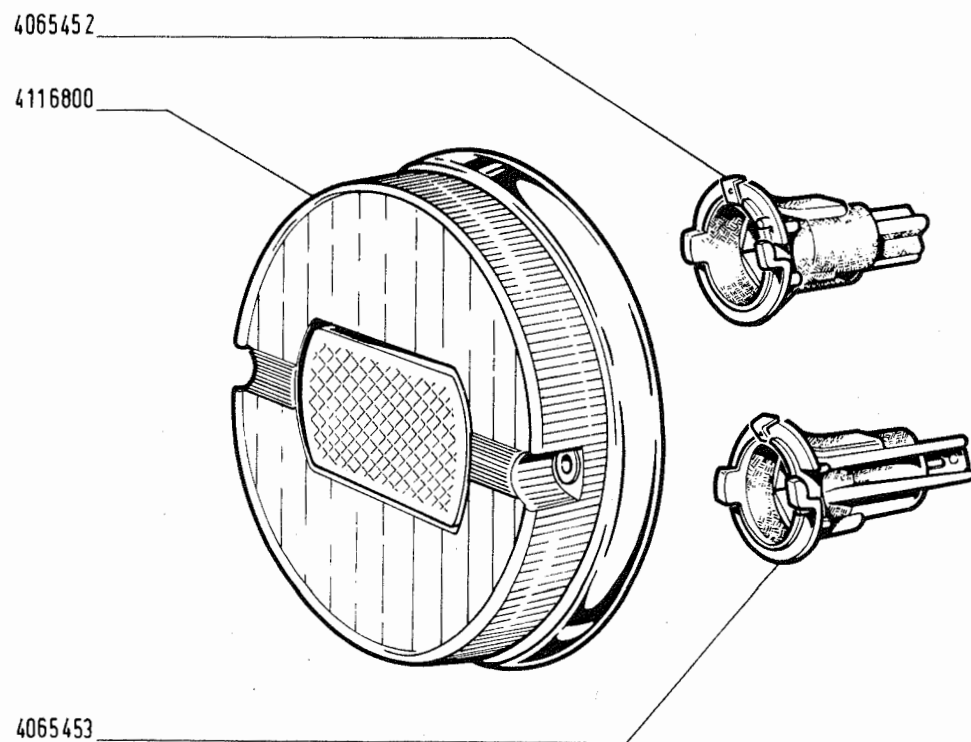

2504

C 3940 → Vett.n. 001074 (05-06)

bianchina
panoramica
e derivati

FANALE POSTERIORE 4116792 (05) (Stars)

- Lanterne AR
- Schlussleuchte

- Tail Lamp
- Lámpara posterior

F6.34/1

modif.	n. ordinaz.	quant.	Denominazione	Désignation	Benennung	Description	Denominaciones
	4065452	1	Portalampada	Porte-lampe	Lampenfassung	Bulb holder	Portalámpara
	4065453	1	Portalampada	Porte-lampe	Lampenfassung	Bulb holder	Portalámpara
	4116800	1	Corpo trasparenti	Corps	Gehäuse	Body	Cuerpo

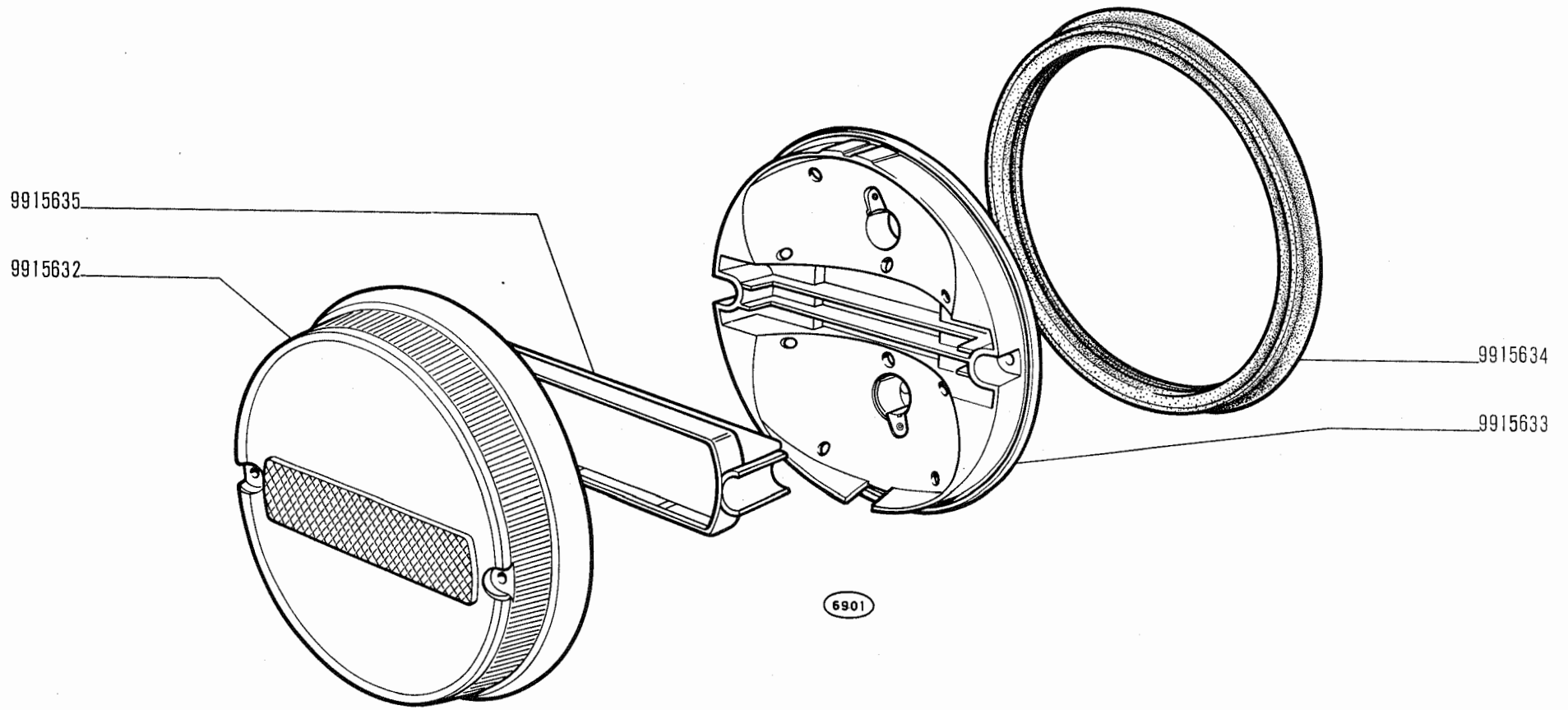

D 3940 Vett.n. 001075 →

blanchina
panoramica
 e derivati

FANALE POSTERIORE 4143136 (05-06) (Stars)

- Lanterne AR
- Schlussleuchte

- Tail Lamp
- Lâmpara posterior

F6.34/2

modif.	n. ordinaz.	quant.	Denominazione	Désignation	Benennung	Description	Denominaciones
	9915632	1	Trasparente	Transparent	Lichtscheibe	Lens	Tapa translúcida
	9915633	1	Corpo	Corps	Gehäuse	Body	Cuerpo
	9915634	1	Anello tenuta	Joint	Dichtring	Seal	Junta
	9915635	1	Separatore luci	Ecran	Trennstück	Spacer	Separador

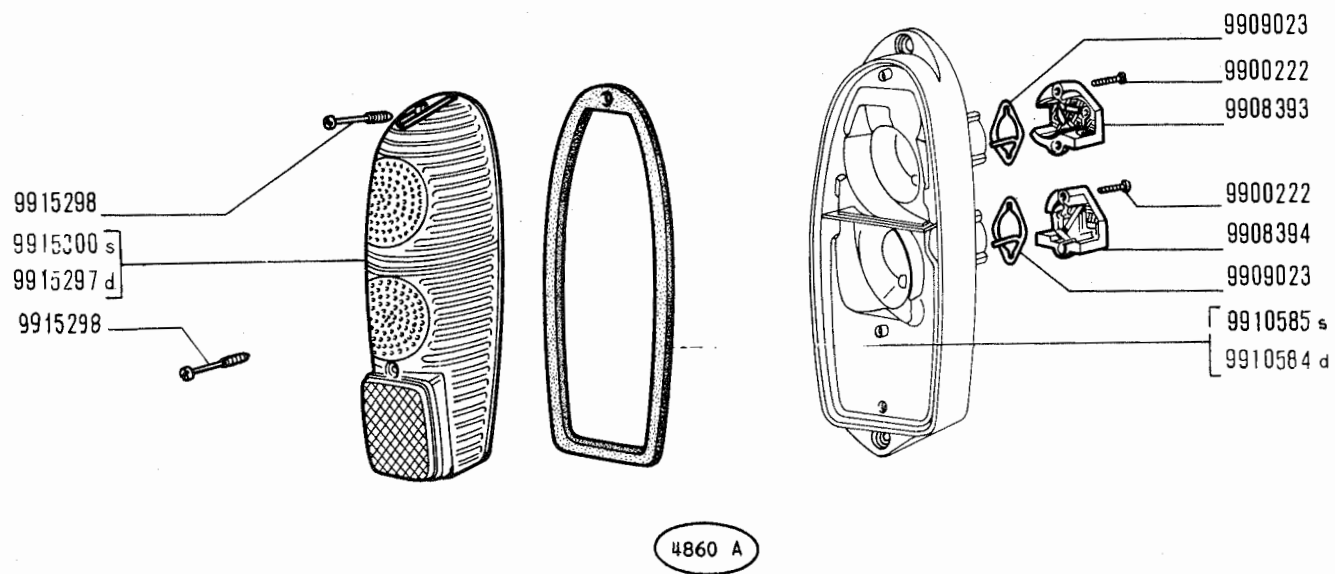

blanchina
panoramica

FANALE POSTERIORE d. 4137061 s. 4137062 (Altissimo)

- Lanterne AR
- Schlussleuchte

- Tail Lamp
- Lámpara posterior

F6.34/3

modif.	n. ordinaz.	quant.	Denominazione	Désignation	Benennung	Description	Denominaciones
	9900222	4	Vite	Vis	Schraube	Screw	Tornillo
	9908393	1	Blocchetto connessione	Plaque de jonction	Anschlussdose	Terminal block	Placa de empalme
	9908394	1	Blocchetto connessione	Plaque de jonction	Anschlussdose	Terminal block	Placa de empalma
	9909023	2	Piastrina contatto	Plaquette	Kontaktplatte	Contact plate	Placa de contacto
	9910584	1	Guarnizione d	Joint	Dichtung	Gasket	Junta
	9910585	1	Guarnizione s	Joint	Dichtung	Gasket	Junta
	9915297	1	Trasparente d	Transparent	Lichtscheibe	Lens	Tapa translúcida
	9915298	1	Vite	Vis	Schraube	Screw	Tornillo
	9915299	1	Vite	Vis	Schraube	Screw	Tornillo
	9915300	1	Trasparente s	Transparent	Lichtscheibe	Lens	Tapa translúcida

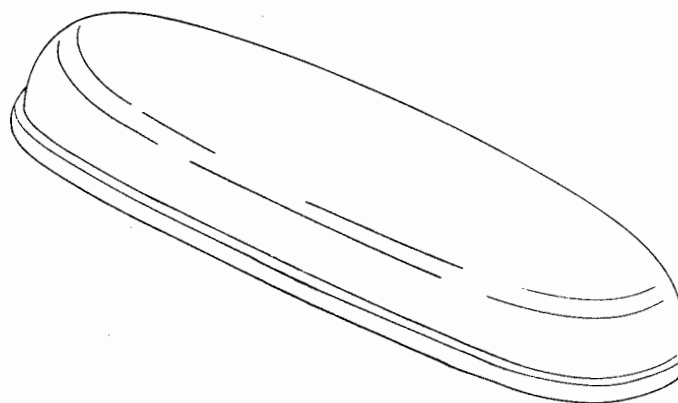

9907311
9908410

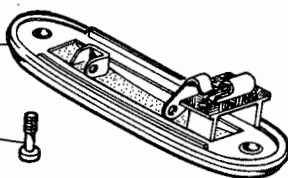

37690 1A

bianchina
panoramica

FANALE TARGA 1106864 (Giuntini)

- Feu de plaque
- Nummernschildleuchte

- Number Plate Lamp
- Lámpara de matrícula

F6.35

modif.	n. ordinaz.	quant.	Denominazione	Désignation	Benennung	Description	Denominaciones
	9907311	1	Portalampada	Porte-lampe	Lampenfassung	Bulb holder	Portalámpara
	9908410	2	Vite	Vis	Schraube	Screw	Tornillo

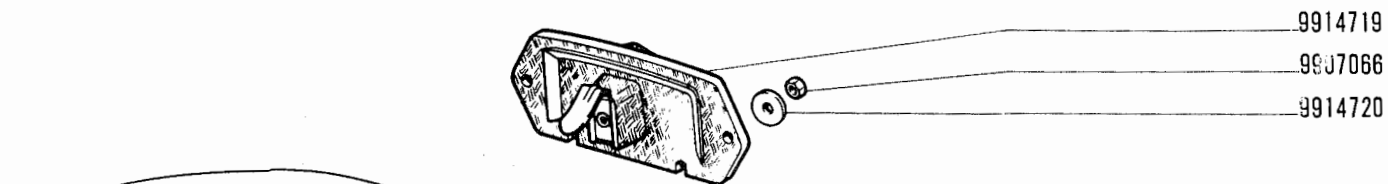

9914719

9907066

9914720

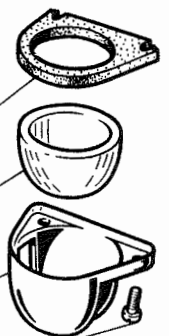
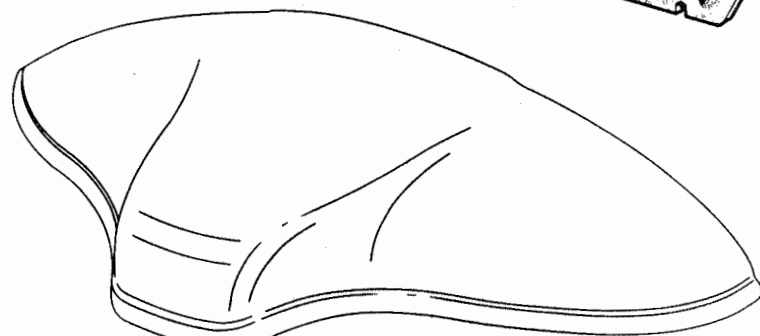

9913869

9911959

9909523

9900233

4212

bianchina
panoramica

FANALE TARGA 4122374 (Altissimo)

- Feu de plaque
- Nummernschildleuchte

- Number Plate Lamp
- Lámpara de matrícula

F6.35/1

modif.	n. ordinaz.	quant.	Denominazione	Désignation	Benennung	Description	Denominaciones
	9907066	2	Dado	Ecrou	Mutter	Nut	Tuerca
	9907228	2	Vite	Vis	Schraube	Screw	Tornillo
	9908274	1	Portalamпада	Porte-lampe	Lampenfassung	Bulb holder	Portalámpara
	9909523	1	Cappuccio paraluce	Capuchon	Schutzkappe	Cap	Pantalla
	9911959	1	Trasparente	Transparent	Lichtscheibe	Lens	Tapa translúcida
	9913869	1	Guarnizione	Joint	Dichtung	Gasket	Junta

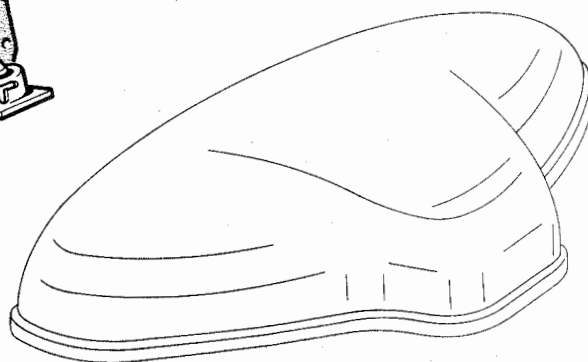
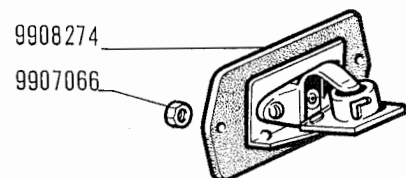

4311

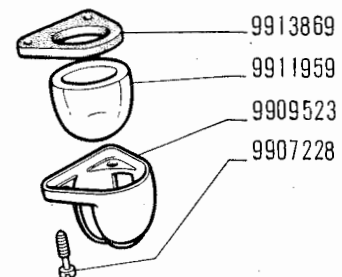

bianchina
panoramica

FANALE TARGA 4056444 (12) (Altissimo)

- Feu de plaque
- Nummernschildleuchte

- Number Plate Lamp
- Lámpara de matrícula

F6.35/2

modif.	n. ordinaz.	quant.	Denominazione	Désignation	Benennung	Description	Denominaciones
	9900233	2	Vite	Vis	Schraube	Screw	Tornillo
	9907066	2	Dado	Ecrou	Mutter	Nut	Tuerca
	9909523	1	Cappuccio paraluce	Capuchon	Schutzkappe	Cap	Pantalla
	9911959	1	Trasparente	Transparent	Lichtscheibe	Lens	Tapa translúcida
	9913869	1	Guarnizione	Joint	Dichtung	Gasket	Junta
	9914719	1	Blocchetto isolante	Isolant	Isolierung	Insulator	Placa aislante
	9914720	2	Rosetta piana	Rondelle	Scheibe	Washer	Arandela

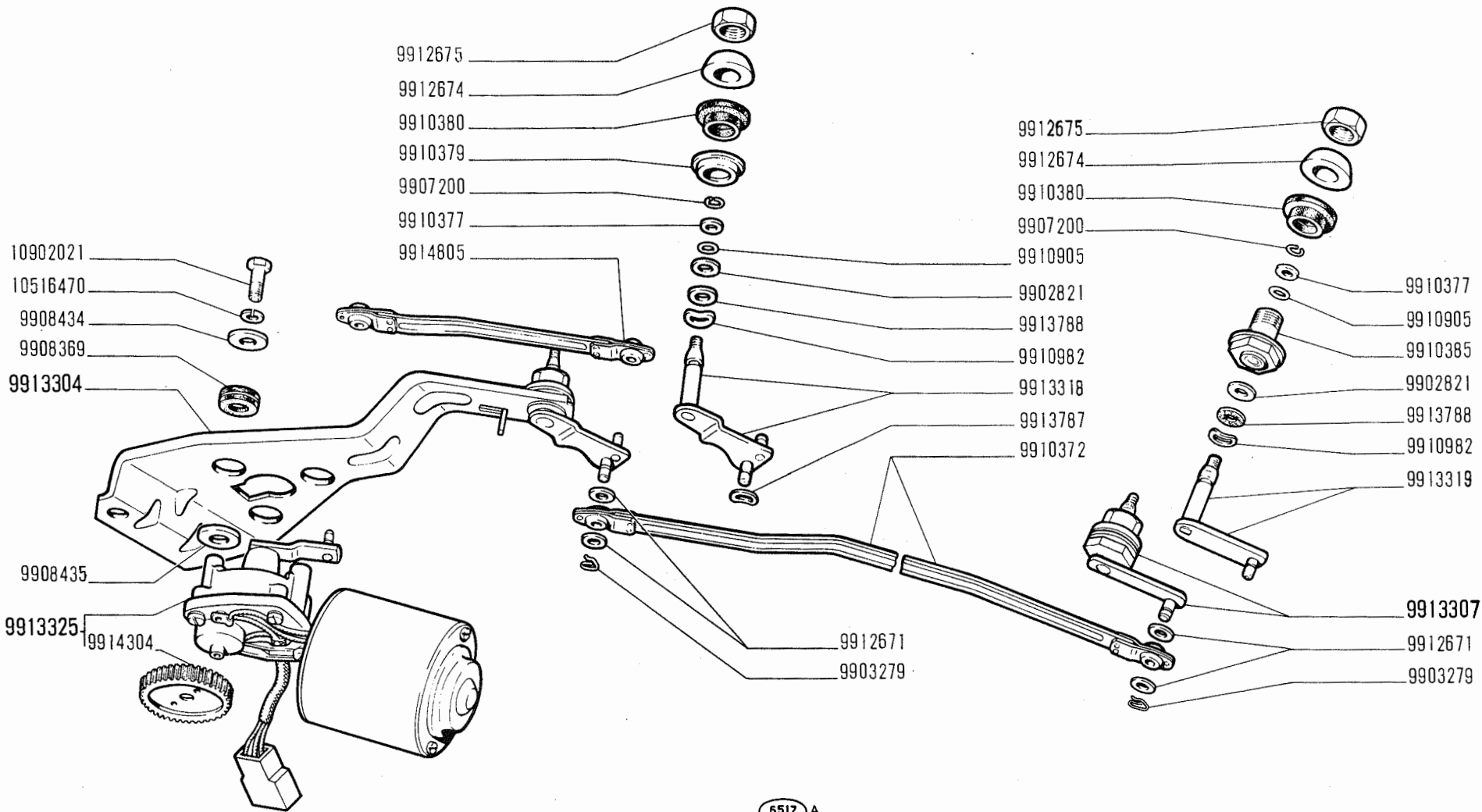

6517 A

blanchina
panoramica

● Essuie-glace
● Scheibenwischer

TERGICRISTALLO 1109190 (Marelli)

● Windshield Wiper
● Limpia-parabrisas

F6.65

modif.	n. ordinaz.	quant.	Denominazione	Désignation	Benennung	Description	Denominaciones
	9902821	2	Rosetta piana	Rondelle	Scheibe	Washer	Arandela
	9903279	4	Fermaglio	Agrafe	Klemmstück	Clip	Sujetador
	9907200	2	Anello sicurezza	Arrêtoir	Sicherungsring	Lockring	Anillo elástico
	9908369	3	Anello gomma	Bague	Ring	Ring	Guarnición
	9908434	3	Rosetta piana	Rondelle	Scheibe	Washer	Arandela
	9908435	3	Rosetta piana	Rondelle	Scheibe	Washer	Arandela
	9910372	1	Tirante	Tirant	Verbindungsstange	Link	Biela
	9910377	2	Rosetta piana	Rondelle	Scheibe	Washer	Arandela
	9910379	1	Scodellino	Cuvette	Tellerscheibe	Cup	Platillo
	9910380	2	Boccola gomma	Bague caoutchouc	Gummibüchse	Rubber bush	Cojinete
	9910385	1	Bussola	Douille	Gewindebüchse	Bushing	Casquillo
	9910905	2	Anello tenuta	Joint	Dichtring	Seal	Junta
	9910982	2	Rosetta sicurezza	Rondelle frein	Sicherungsring	Lochwasher	Arandela de freno
	9912671	8	Rosetta piana	Rondelle	Scheibe	Washer	Arandela
	9912674	2	Distanziale	Entretoise	Abstandstück	Spacer	Separador
	9912675	2	Dado	Écrou	Mutter	Nut	Tuerca
	9913304	1	Piastra compl.	Plaque	Platte	Plate	Placa
	9913307	1	Perno destro compl.	Axe	Bolzen	Pin	Eje
	9913318	1	Leva con perno s	Axe	Bolzen	Pin	Eje
	9913319	1	Leva con perno	Axe	Bolzen	Pin	Eje
	9913325	1	Motorino compl.	Moteur	Motor	Motor	Motor
	9913787	4	Rosetta sicurezza	Rondelle frein	Sicherungsring	Lockwasher	Arandela de freno
	9913788	2	Rosetta piana	Rondelle	Scheibe	Washer	Arandela
	9914304	1	Ingranaggio	Pignon	Zahnrad	Gear	Piñón
	9914805	1	Biella	Bielle	Pleuel	Link	Biela
	10516470	3	Rosetta sicurezza	Rondelle frein	Sicherungsring	Lockwasher	Arandela de freno
	10902021	3	Vite	Vis	Schraube	Screw	Tornillo

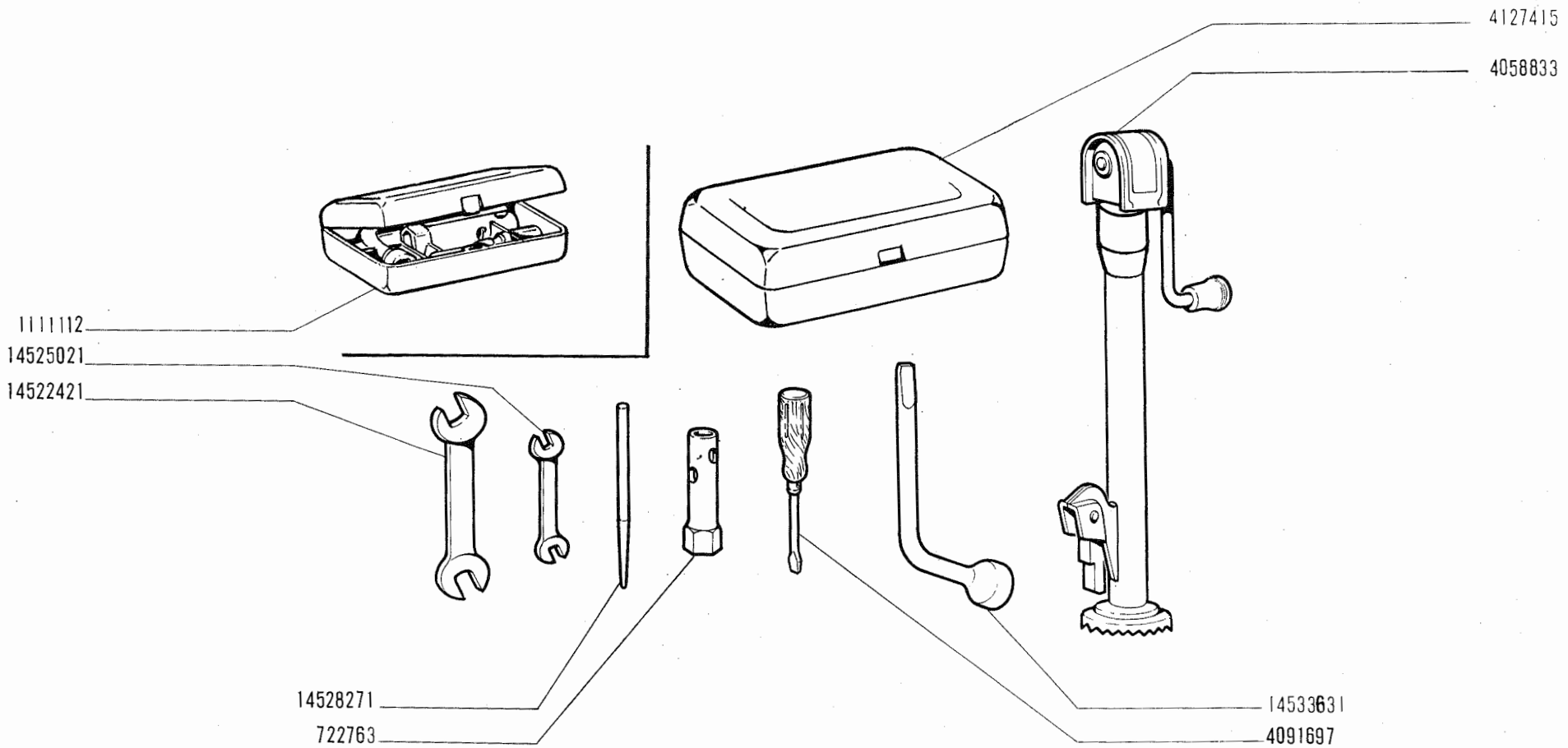

1301/9 B

modif.	n. ordinaz.	quant.	Denominazione	Désignation	Benennung	Description	Denominaciones
	722763	1	Chiave a tubo	Clé à tube	Steckschlüssel	Pipe wrench	Llave de tubo
	1111112	1	Borsa compl.	Trousse à outils	Werkzeugtasche	Box, w/tools	Bolsa
	4058833	1	Martinello	Cric	Wagenheber	Jack	Gato
	4091697	1	Cacciavite	Tournevis	Schraubenzieher	Screwdriver	Destornillador
	4127415	1	Borsa utensili	Trousse à outils	Tasche	Box	Bolsa
	14522421	1	Chiave 13 × 17	Clé	Schlüssel	Wrench	Llave
	14525021	1	Chiave 8 × 10	Clé	Schlüssel	Wrench	Llave
	14528271	1	Punzone diritto	Chasse-goupille	Durchschlag	Punch, straight	Punzón
	14533631	1	Manovella	Manivelle	Radmutterschlüssel	Speed handle	Manivela

M o d i f i c a		Sgr. interessati e Norme di ricambio
C 2478 IX - 1965	D 2478 IX - 1965	F6.02 (N.T. 15)
C 2609 → mot. n. 272279	D 2609 mot. n. 272280 →	A2.02 (N.T. 15) 4082585 = D 2609
C 2614 → mot. n. 269792	D 2614 mot. n. 269793 →	A1.07 (N.T. 15) 4064492 = 4137985 + 4115148 + 4115149
C 2638	D 2638	A3.01 (N.T. 15) 4015465 = 4067806 F5.01: 4125725 = 4141676 oppure 4141677 F5.03: 4055044 = 4141678 4056886 = 4141679
C 2603 → II - 1966	D 2603 II - 1966 →	A2.03 (N.T. 19) 9914386 = 9915941
C 2678 → XII - 1966	D 2678 XII - 1966 →	D3.05 (N.T. 19) 894037 = 4101670 + 16105011
C 2741 → mot. n. 288155 mot. n. 286634 (13)	D 2741 mot. n. 288156 → mot. n. 286635 (13) →	A0.01 - A1.02 - A2.04 - A3.01 - A4.07 (N.T. 19)

M o d i f i c a		Sgr. interessati e Norme di ricambio
C 2758 → XI - 1966	D 2758 XI - 1966 →	F6.02 (N.T. 21) 4111374 = D 2758
C 2760 → mot. n. 296833	D 2760 mot. n. 296834 →	A1.01 (N.T. 19) 4124025 = 4159060 + 4159058 404706T = n. 2 4159058
C 2775 → mot. n. 298486	D 2775 mot. n. 298487 →	A3.01/1 (N.T. 19) 4067806 = 4151243 + 4151245 988447 = 4151245
C 2854 → I - 1967	D 2854 I - 1967 →	B2.01 (N.T. 21) 970679 = 4162065 1035861T = 13303611 + 12606970
C 2883 → mot. n. 315142	D 2883 mot. n. 315143 →	A2.02 (N.T. 21) 4121172 = 4167919
C 2885 → mot. n. 318144	D 2885 mot. n. 318145 →	F3.01 (N.T. 21) 4056203 = 4146046
C 2989 → veic. n. 131721 (01-02) → veic. n. 131729 (03-04-05-06)	D 2989 veic. n. 131722 (01-02) → veic. n. 131730 (03-04-05-06) →	C1.32 (N.T. 23)

M o d i f i c a		Sgr. interessati e Norme di ricambio
C 3940 → veic. n. 001074	D 3940 veic. n. 001075 →	F4.01/3 (N.T. 20) 1107250 = 1114061
C 4121 → veic. n. 119834	D 4121 veic. n. 119835 →	C1.01 (N.T. 20) 816159 = 4141757 987379 = 4144433
C 4388 → veic. n. 122605	D 4388 veic. n. 122606 →	F4.01 (N.T. 19)
C 4404 → veic. n. 125600 (01-02) veic. n. 125637 (03-04-05-06)	D 4404 veic. n. 125601 (01-02) → veic. n. 125638 (03-04-05-06)	A2.21 (N.T. 21) 4092508 = 4157182 13825821 = 13825721
C 4668 → veic. n. 132848	D 4668 veic. n. 132849 →	B2.07 (N.T. 21) 4019754 = 4169420 + 4169421
C 4678 → veic. n. 152490 (01-02-03-04) veic. n. 002609 (05-06) veic. n. 299233 (07-08)	D 4678 veic. n. 152491 (01-02-03-04) → veic. n. 002610 (05-06) veic. n. 299234 (07-08)	C1.02
C 4745 → veic. n. 138601 (01-02) veic. n. 138602 (03-04) veic. n. 001399 (05-06) veic. n. 212379 (07-08)	D 4745 veic. n. 138602 (01-02) → veic. n. 138603 (03-04) veic. n. 001400 (05-06) veic. n. 212380 (07-08)	B2.24 4029072 = 4171013 + 4170839
C 4770 → veic. n. 148741 (01-02) C 4830 veic. n. 149585 (03-04) veic. n. 002583 (05-06)	D 4770 veic. n. 148742 (01-02) → D 4830 veic. n. 149586 (03-04) veic. n. 002584 (05-06)	F4.01 - F4.01/1 - F4.01/3 - E3.01 - E3.01/1

PARTI DI RICAMBIO RIV

Pièces détachées

Ersatzteile

Spares

Piezas de recambio

CUSCINETTI

Roulements

Wälzlager

Bearings

Rodamientos

Dimensioni mm						n. ordinaz. AUTOBIANCHI	n. ordinaz. RIV	Sgr.
Dimensions		Abmessungen		Dimensiones				
Diametro interno	Diametro esterno	Spessore						
<i>Diamètre int.</i> <i>Innendurchmesser</i>	<i>Inner diameter</i> <i>Diám. int.</i>	<i>Diamètre ext.</i> <i>Aussendurchmesser</i>	<i>Outer diameter</i> <i>Diám. ext.</i>	<i>Epaisseur</i> <i>Breite</i>	<i>Thickness</i> <i>Ancho</i>			
15		35		11		336501	01/02/4808	D2.02
15		42		13		336658	05/02/4911	D3.14
26		52		15		804862	01/28/4016	B4.01
40		70		17		891605	01/02/3740	B4.04
22		56		15		969870	11317b	B2.04
22		47		18		969876	11316a	B2.04
21,8		48/53		20,6		975664	11658/053	B2.04
20		47		14		20888670	1A20	B2.04
12		37		12		24940010	2B/053	F6.02
23		52		15		60055388	01/06/4016	D3.14

AMMORTIZZATORI Amortisseurs Stossdämpfer			BOCCOLE Douilles Büchsen		
Shock Absorbers Amortiguadores			Bushings Casquillos		
n. ordinaz. AUTOBIANCHI	n. ordinaz. RIV	Sgr.	n. ordinaz. AUTOBIANCHI	n. ordinaz. RIV	Sgr.
4048307	808.3010.205	D3.01	890400	89.803.611	D3.01
4059006	808.3010.242	D3.05	890415	89.800.612	D3.01
			4044416	89.802.778	D3.05
			4082332	89.801.686	D2.10

CAVI PER IMPIANTO ELETTRICO (forniti a metri)

Câbles électriques (livrés par mètres)

Electrical Cables (supplied by the meter)

Elektrische Leitungen (vom laufenden Meter erhältlich)



Cables eléctricos que se suministran por metros



COLORE ISOLAMENTO	COULEUR ISOLANT	FARBE U. ISOLIERUNG	COLOR AND INSULATION	COLORES DEL FORRO	Sezione in mm ²		Section en mm ²		Querschnitt in mm ²		Cross-section in mm ²		Secciones en mm ²	
					0,5	1	1,5	2,5	4	6	10			
n. ordinaz.														
Viola	Violet	Violett	Violet	Morado										
Grigio verde	Gris-vert	Graugrün	Green-gray	Gris-verde										
Bianco	Blanc	Weiss	White	Bianco	1 91400 90									
Nero	Noir	Schwarz	Black	Negro		1 91420 90								
Azzurro	Bleu	Blau	Blue	Azul		1 91401 90			1 91431 90				1 91405 90	1 91406 90
Marrone	Marron	Braun	Brown	Pardo		1 91421 90			1 91403 90					
Giallo	Jaune	Gelb	Yellow	Amarillo		1 91419 90			1 91436 90	1 91404 90				
Rosso	Rouge	Rot	Red	Rojo		1 91422 90			1 91433 90	1 91437 90				
Verde	Vert	Grün	Green	Verde		1 91423 90			1 91424 90					
Grigio	Gris	Grau	Gray	Gris		1 91425 90			1 91425 90					
Rosa	Rose	Rosa	Pink	Rosa		1 91426 90			1 91426 90					
Bianco con rigatura nera	Blanc avec rayure noire	Weisschwarz	White with black tracer	Bianco y negro		1 91427 90								
Azzurro con rigatura nera	Bleu avec rayure noire	Blauschwarz	Blue with black tracer	Azul y negro			1 91428 90							
Giallo con rigatura nera	Jaune avec rayure noire	Gelbschwarz	Yellow with black tracer	Amarillo y negro			1 91429 90							
Verde con rigatura nera	Vert avec rayure noire	Grünschwartz	Green with black tracer	Verde y negro			1 91418 90							
Grigio con rigatura nera	Gris avec rayure noire	Grauschwarz	Gray with black tracer	Gris y negro			1 91439 90							
In resina sintetica per cavo accensione motore	En résine synthétique pour fils de bougies	Aus Kunstharz für Zündkabel	Synthetic resin, for engine ignition cable	De resina sintética: cable de encendido del motor			1 91100 94 1 91551 90(13)							



CAPICORDA E CAPPUCCI ISOLANTI PER CAVI ELETTRICI



Cosses et capuchons isolants pour câbles électriques
Tabelle der Kabelschuhe und Schutzkappen

Electrical Cable Terminals and Boots List
Terminales y capuchones aislantes de cables eléctricos

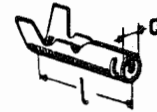
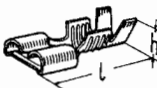
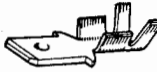
		n. ordinaz.
		1 04015 90
		1 20560 40
	d	
	l_1	
3,2	22	1 04106 40
4,3	24	1 04107 40
6,4	29	1 04109 40
5,3	27	1 04110 40
8,4	33	1 04128 40

		n. ordinaz.
		1 04111 40
	d	
6,2	3,8	1 04046 40
6,2	7	1 04047 40
5,2	3,2	1 04048 40
6,2	4,5	1 04049 40
	a	
	h	
14	5,5	1 04017 44
15	7,5	1 04019 44

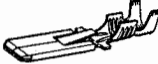
		n. ordinaz.
	d	
3,85	17,2	1 05020 74
4,35	20,4	1 05022 74
	h	
	l	
5,2	19,3	1 02497 40
6,4	19,7	1 02498 44
		1 02501 40
		1 02505 40

		n. ordinaz.
		1 02506 40
	D	
	d	
14	4,5	1 04051 86
14	6,5	1 04052 80
	D	
	d	
10	7	1 04053 80
15	7	1 04054 85
15	10	1 04055 80
20	12,5	1 04056 80